



Microbit Robotics Beginner Level 2

Lesson 5

UFO catcher

Presented by Advanced Superlogic Team

Today's Topic

- 1. Build UFO catcher with World of Modules**
- 2. Rocker and variables programming**
- 3. Servo programming**

Learning Outcome

- 1. Able to build UFO Catcher with instruction manual**
- 2. Understand Rocker and variables programming**
- 3. Understand Servo programming work**
- 4. Able to program UFO catcher**

Lets build UFO catcher

Step 1

The diagram illustrates the assembly of two white Technic beams. A blue callout box in the top-left corner shows a black pin with the quantity 'x4' and a white Technic connector with the quantity 'x2'. The main assembly area shows two white Technic beams, one on the left and one on the right. Four black pins are positioned to connect the beams: two are already inserted into the top holes of both beams, and two are shown below, ready to be inserted into the bottom holes. Two white Technic connectors are positioned between the beams, ready to be attached to the top and bottom holes of both beams.

754

Step 2



755

Step 3

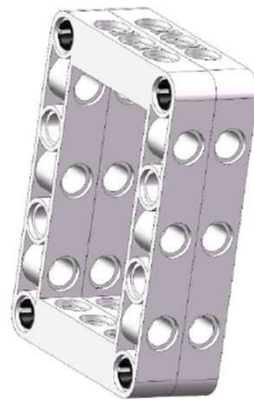

756

Step 4

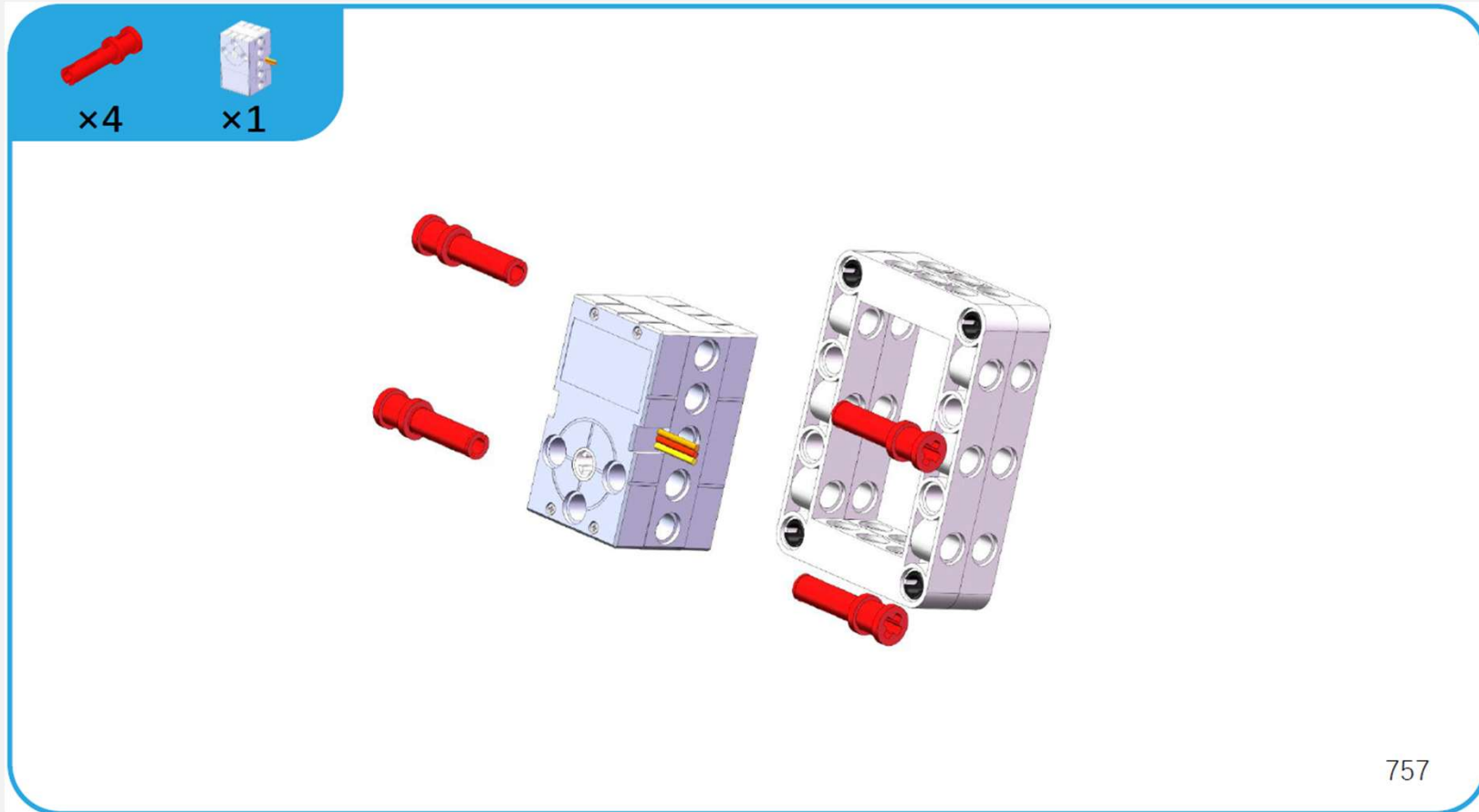

757

Step 5

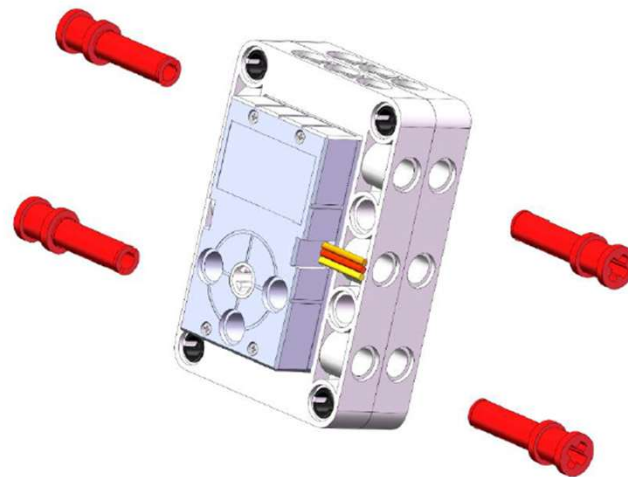

758

Step 6

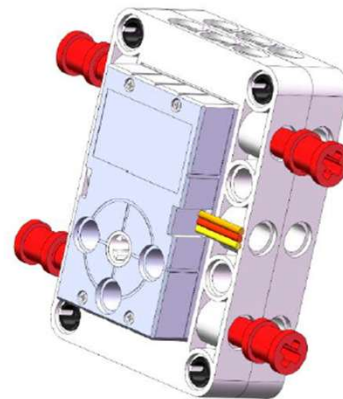

759

Step 7

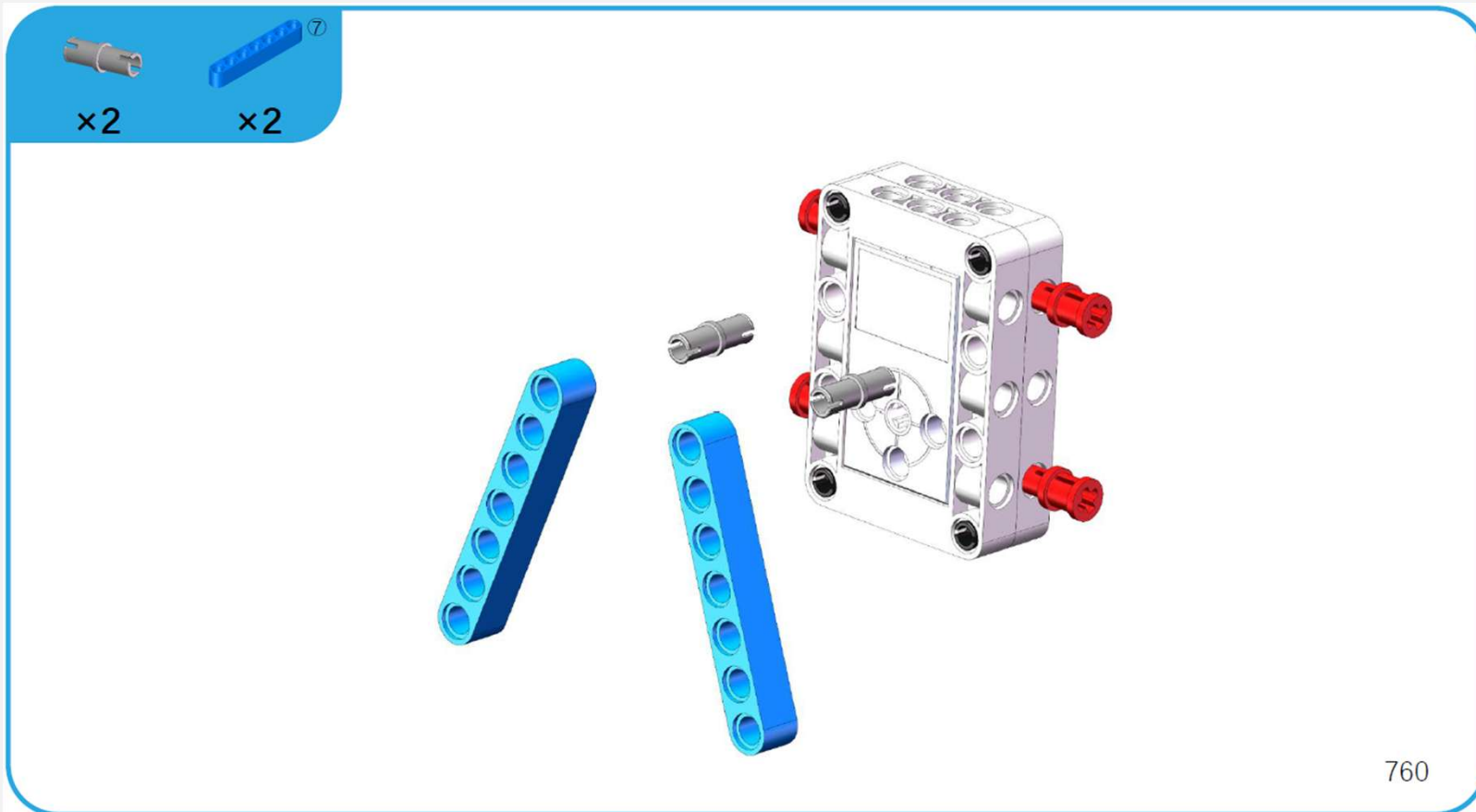

Step 8

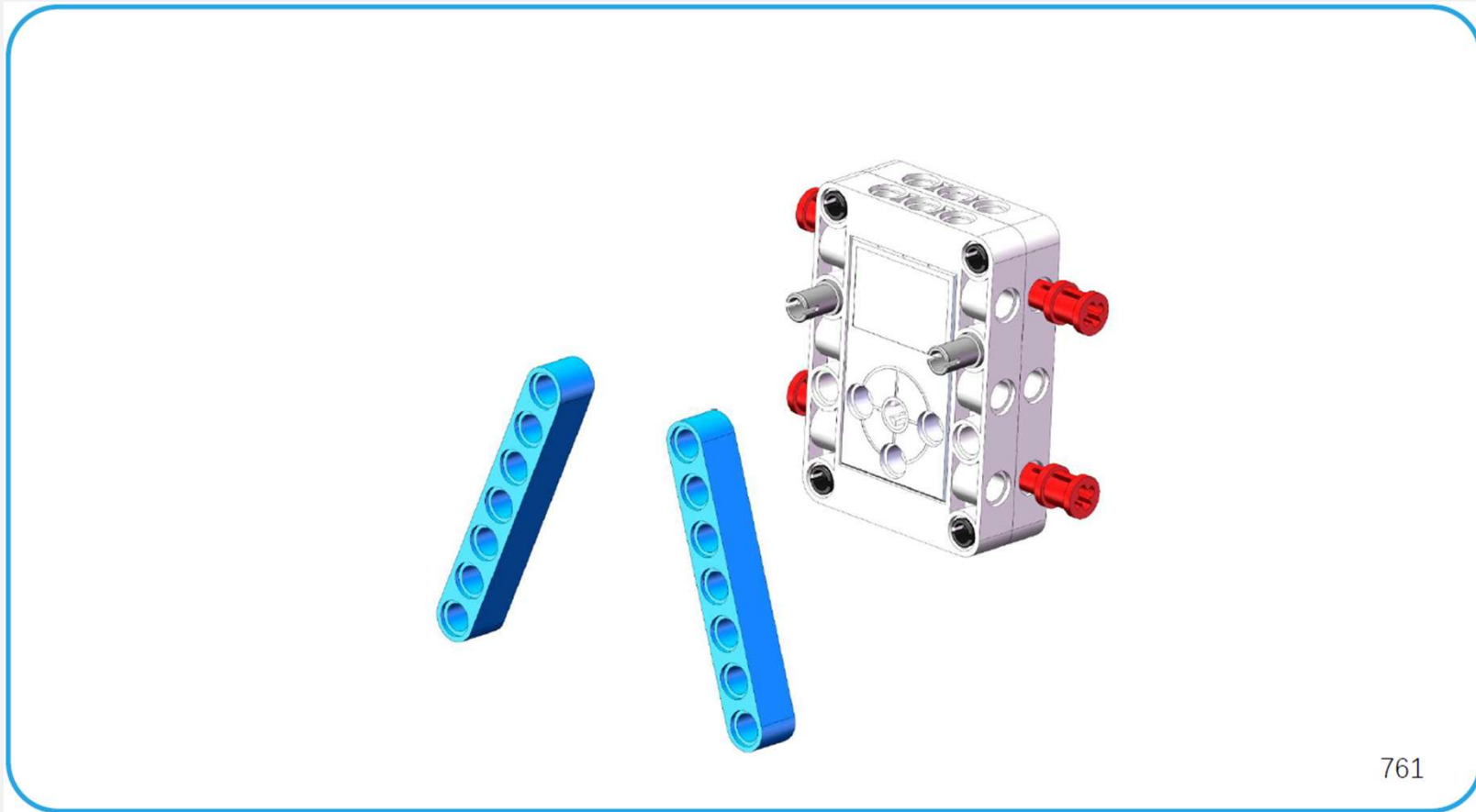

761

Step 9

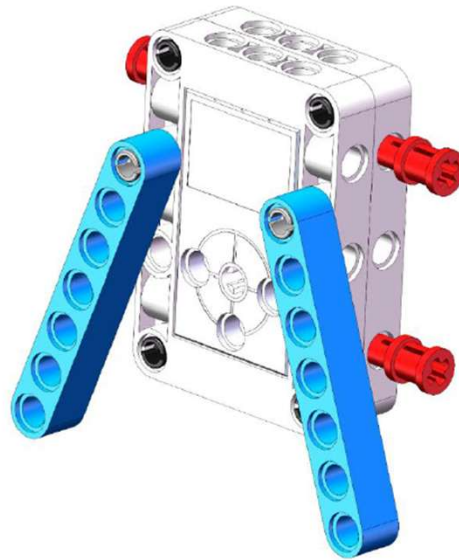

762

Step 10

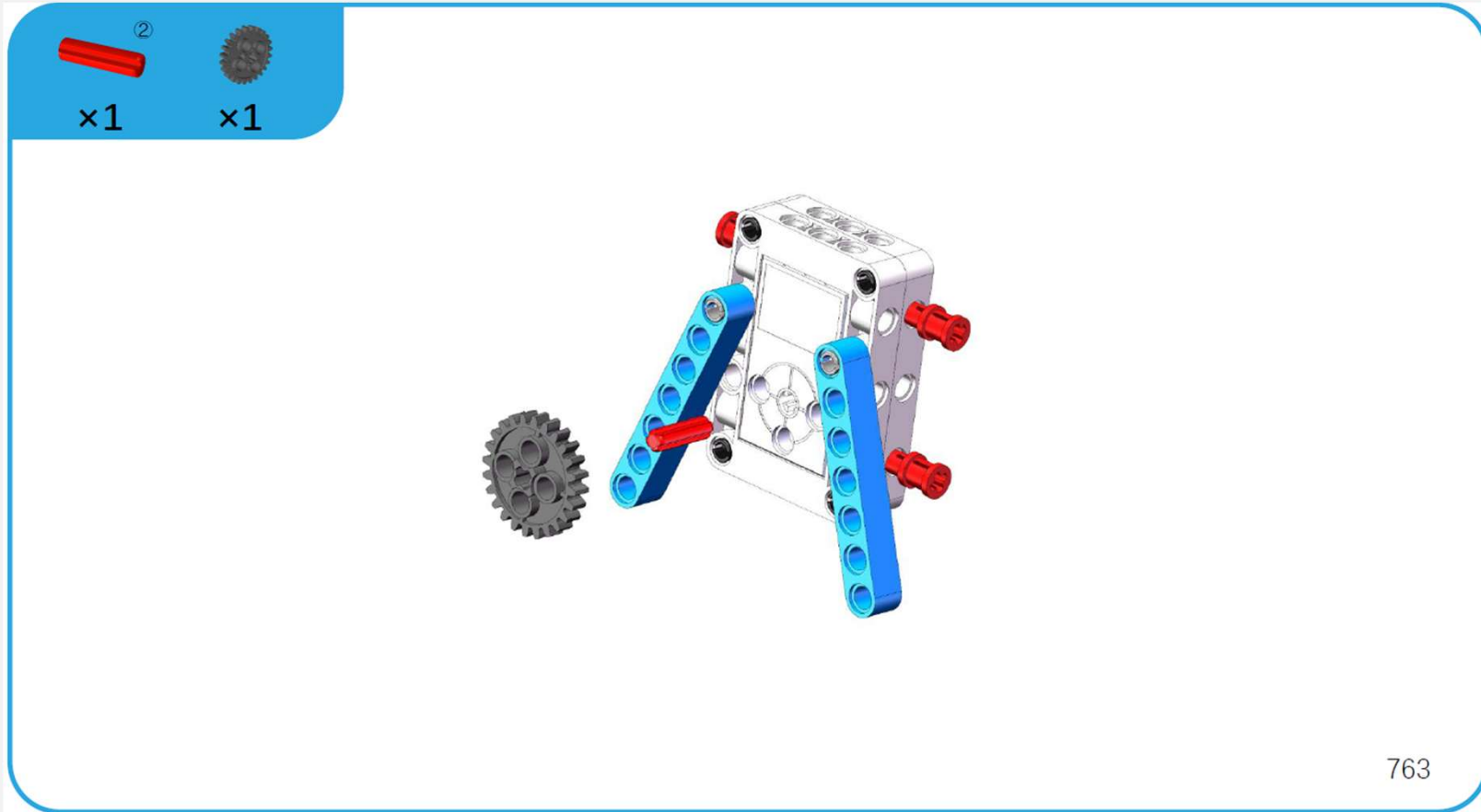

763

Step 11

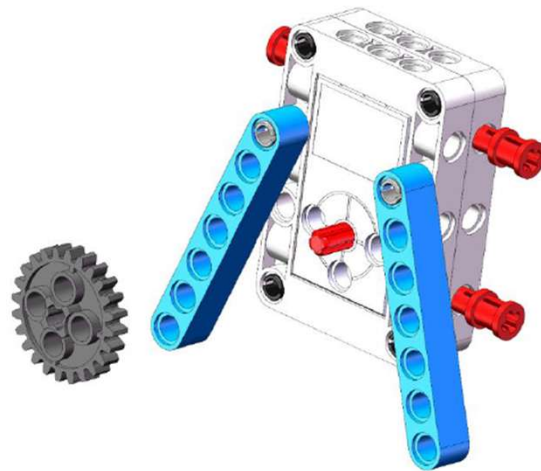

764

Step 12

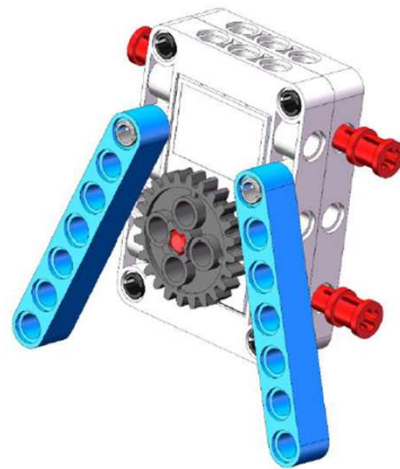

765

Step 12 – Set servo P2 Position

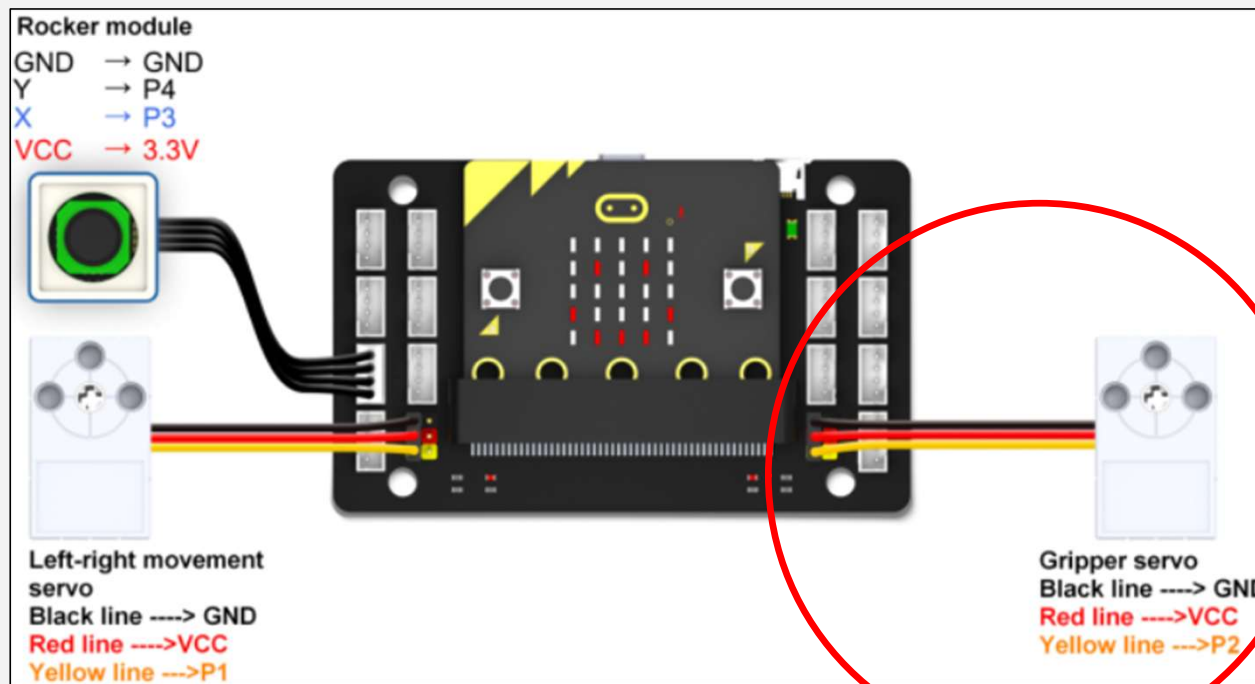

Let's plug in the servo to P2, then we need to set the servo program to make it go to starting position at 140.

Step 12 – Set servo P2 Position

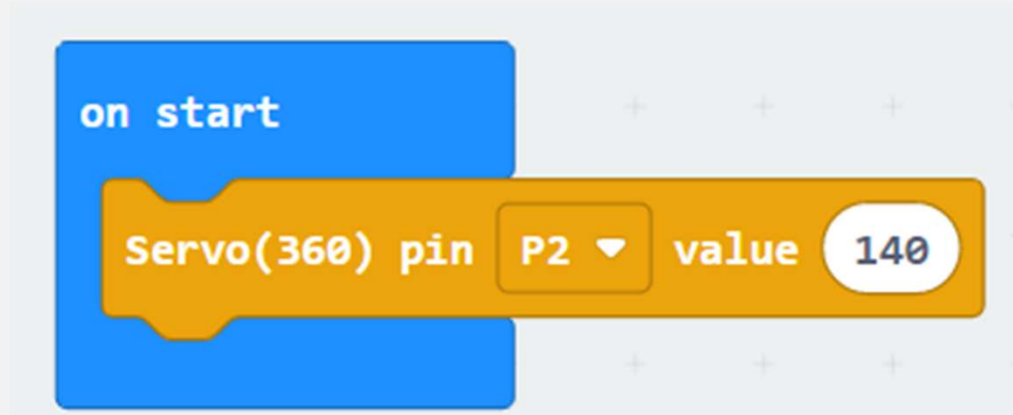

Before proceeding to next step, we need set the servo to starting position = 140 first.

After done the coding shown at left, click download to download this script to your microbit.

Step 13



x4



x2

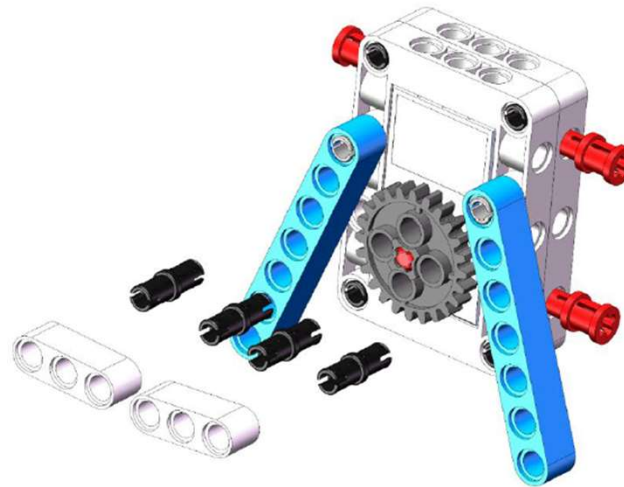

766

Step 14

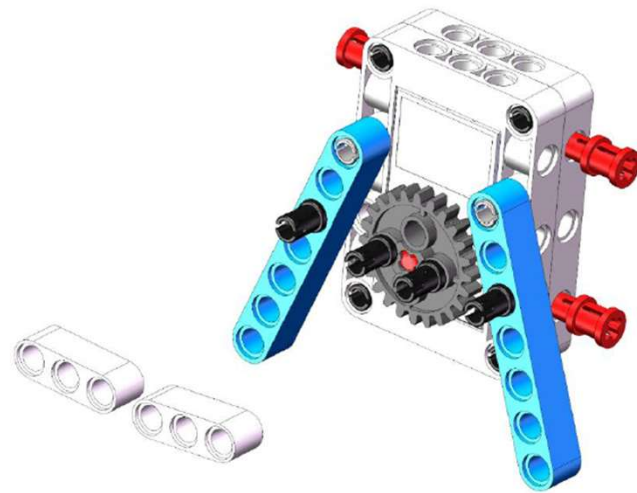

767

Step 15

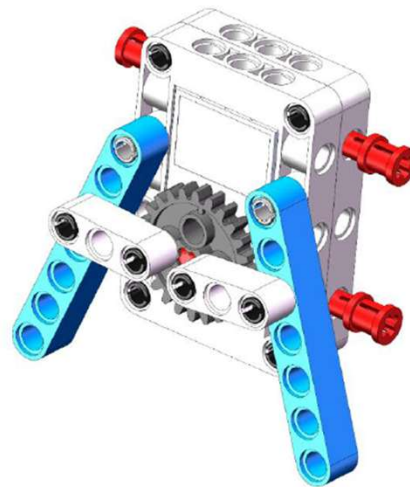

768

Step 16

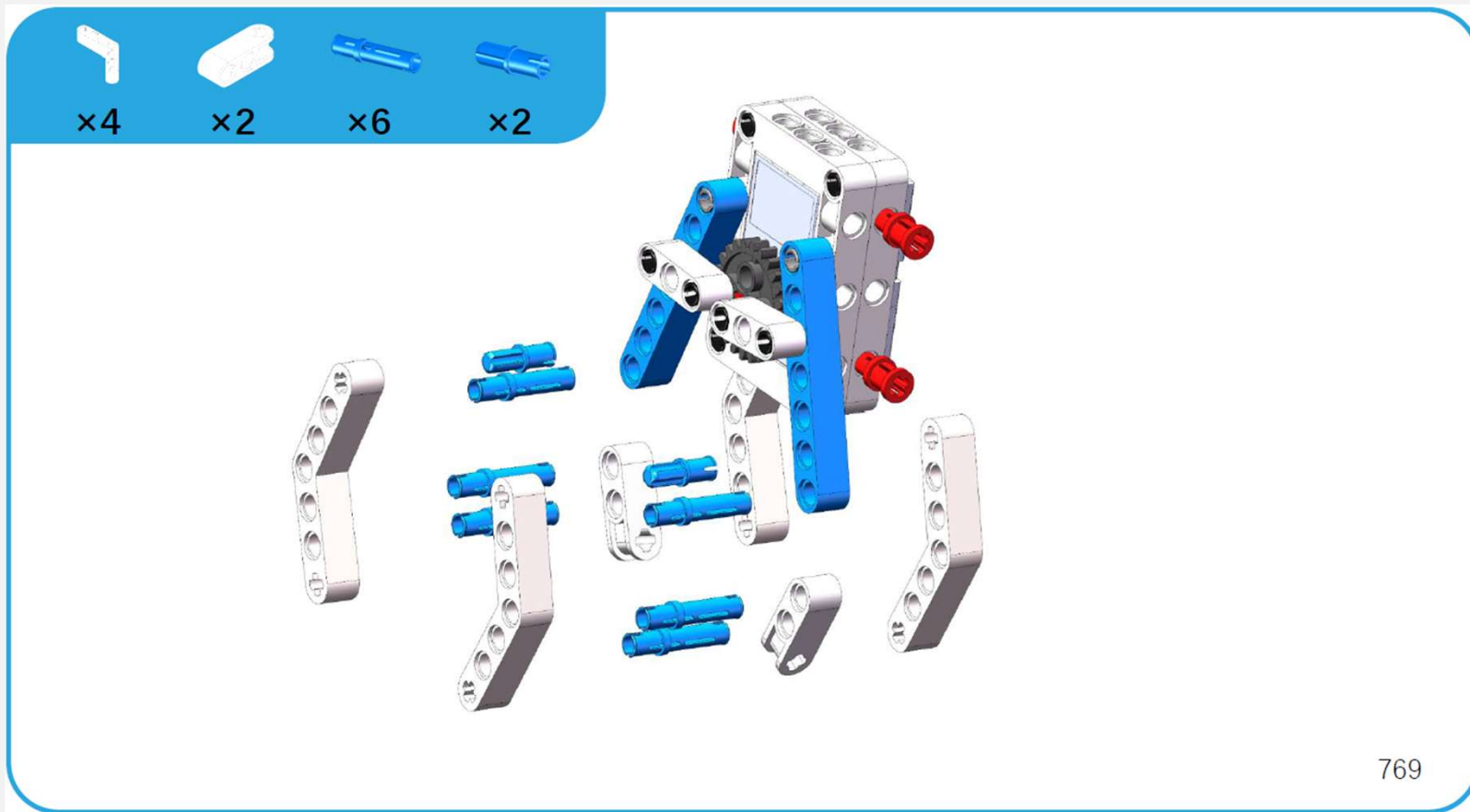

Step 17

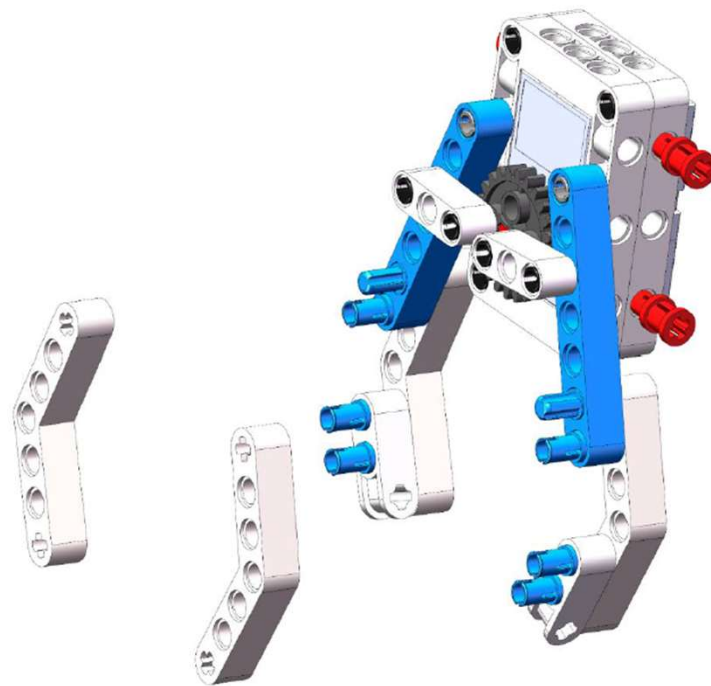

770

Step 18

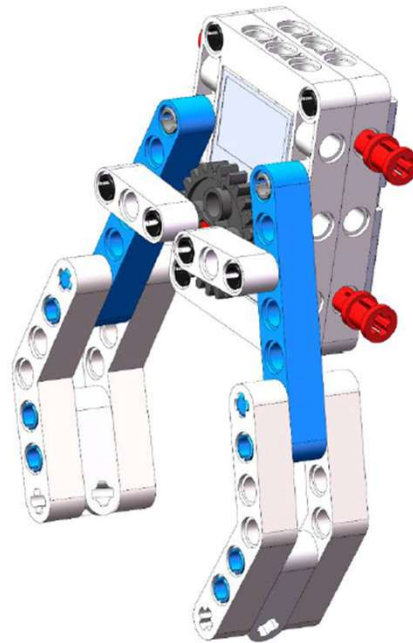

771

Step 19

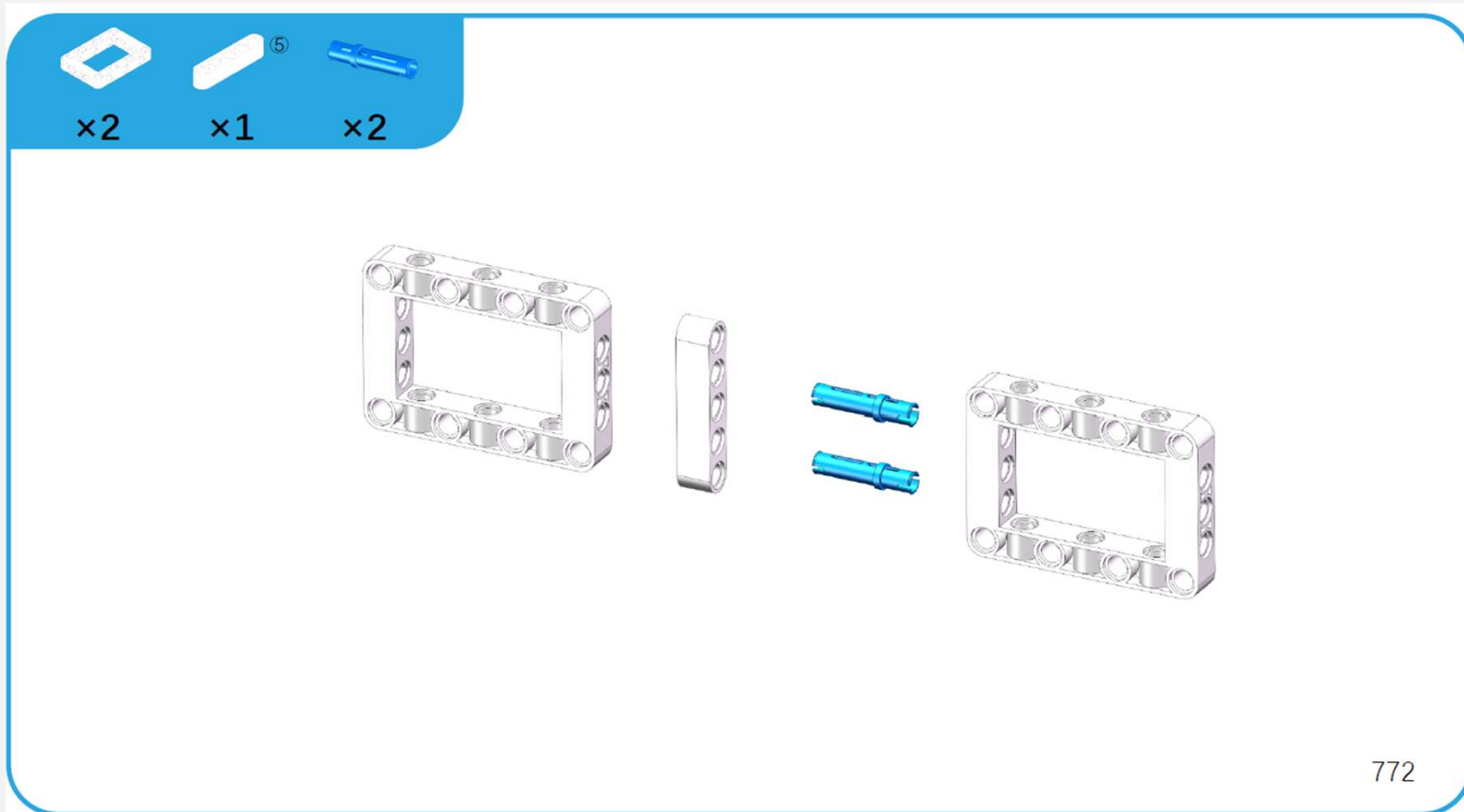

Step 20

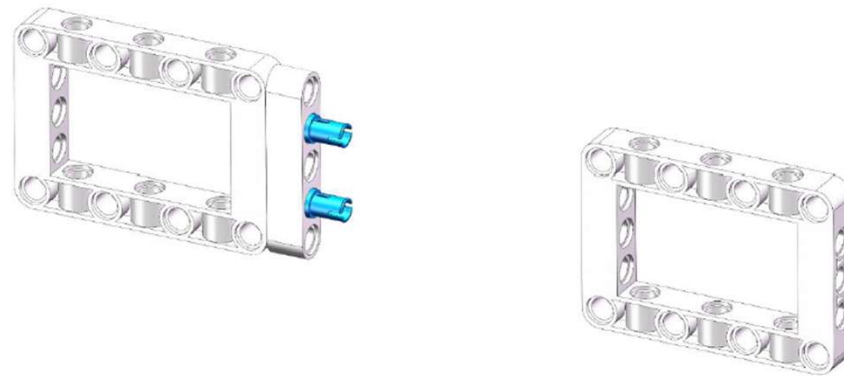

773

Step 21

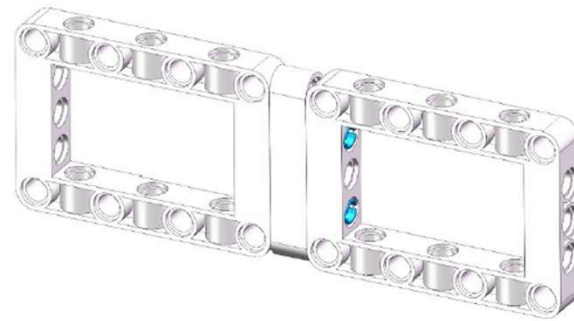

774

Step 22

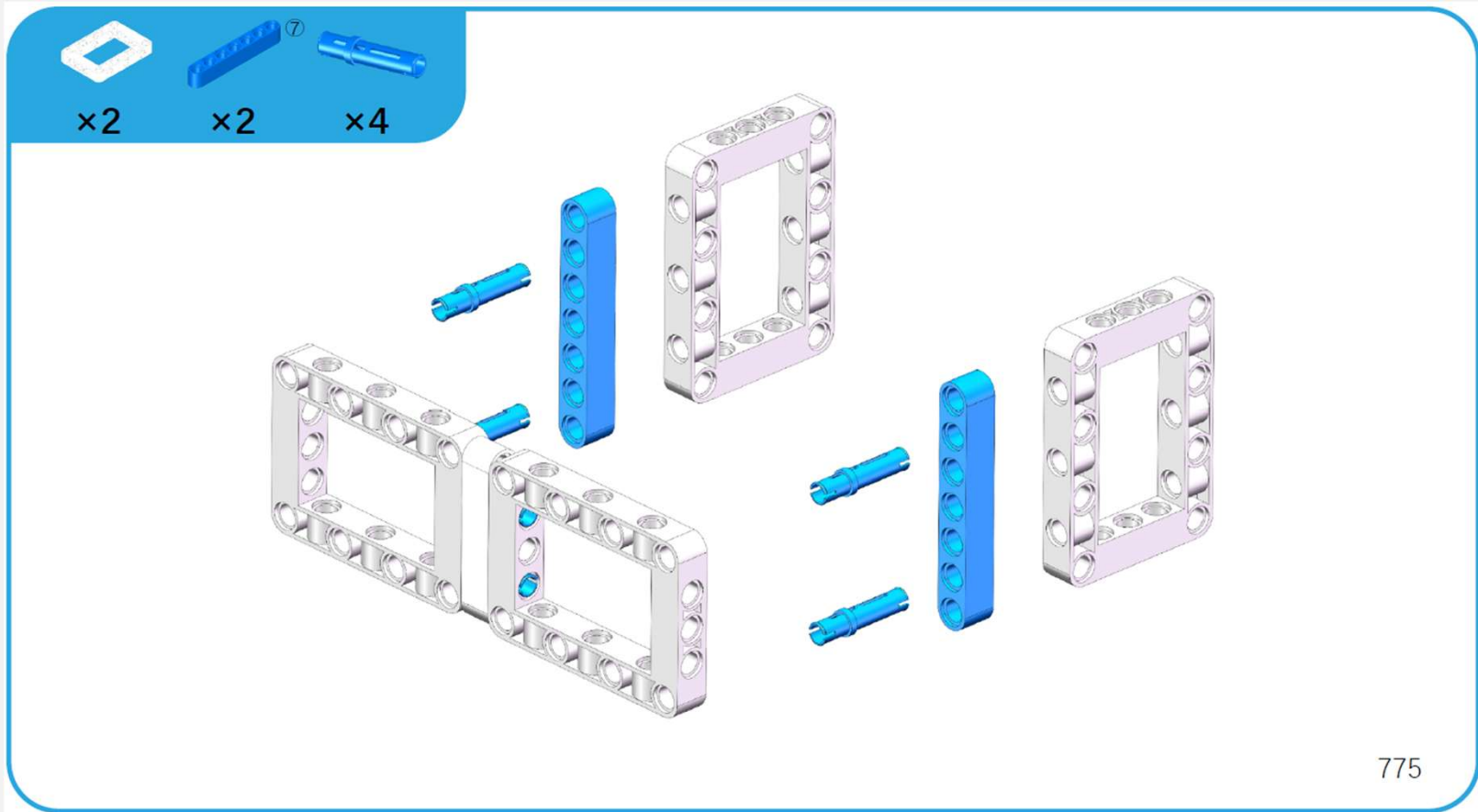

Step 23

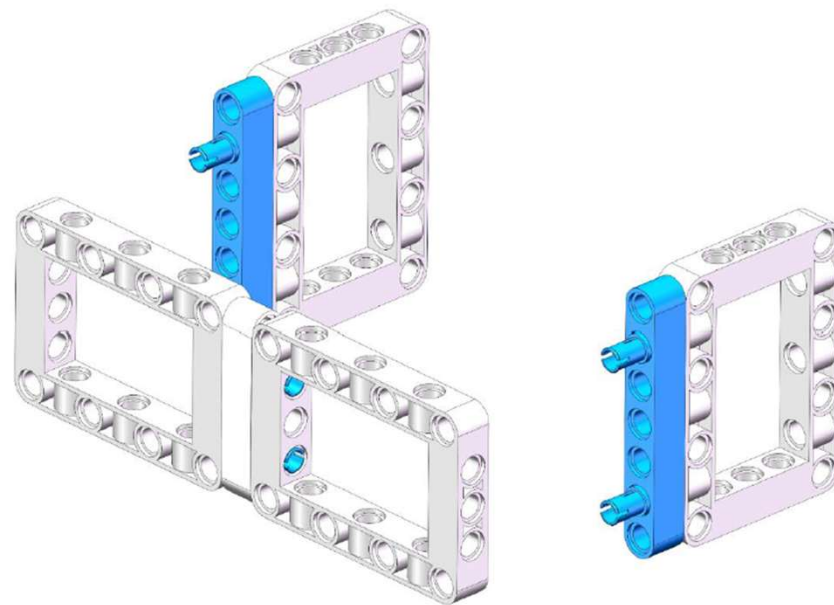

776

Step 24

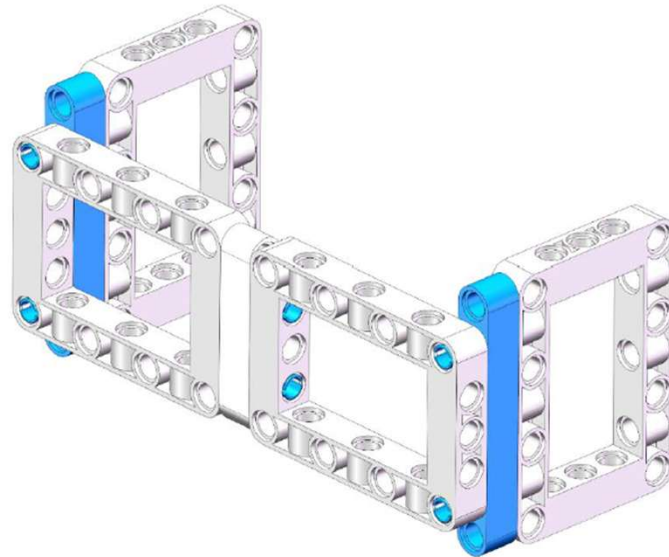

777

Step 25

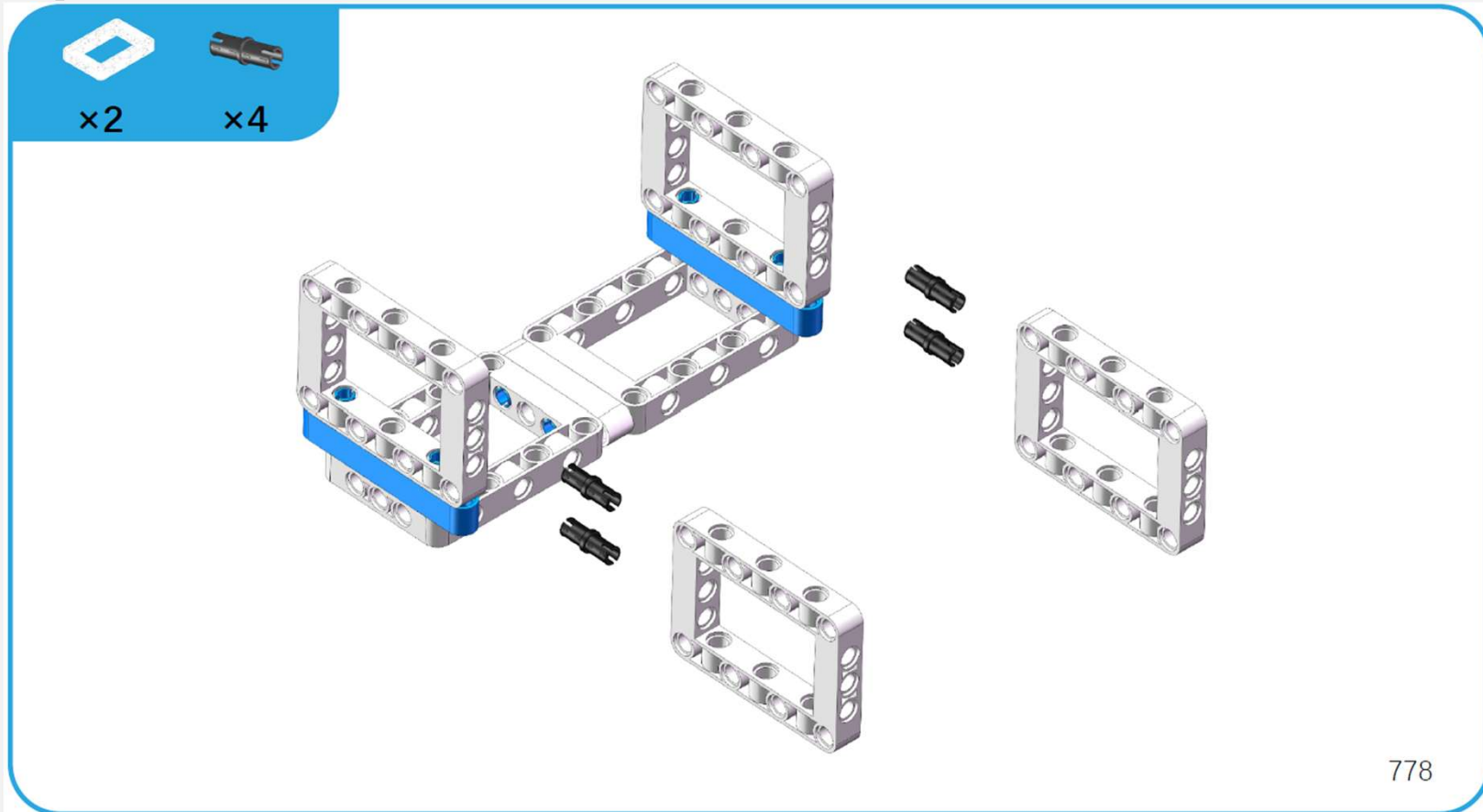

Step 26

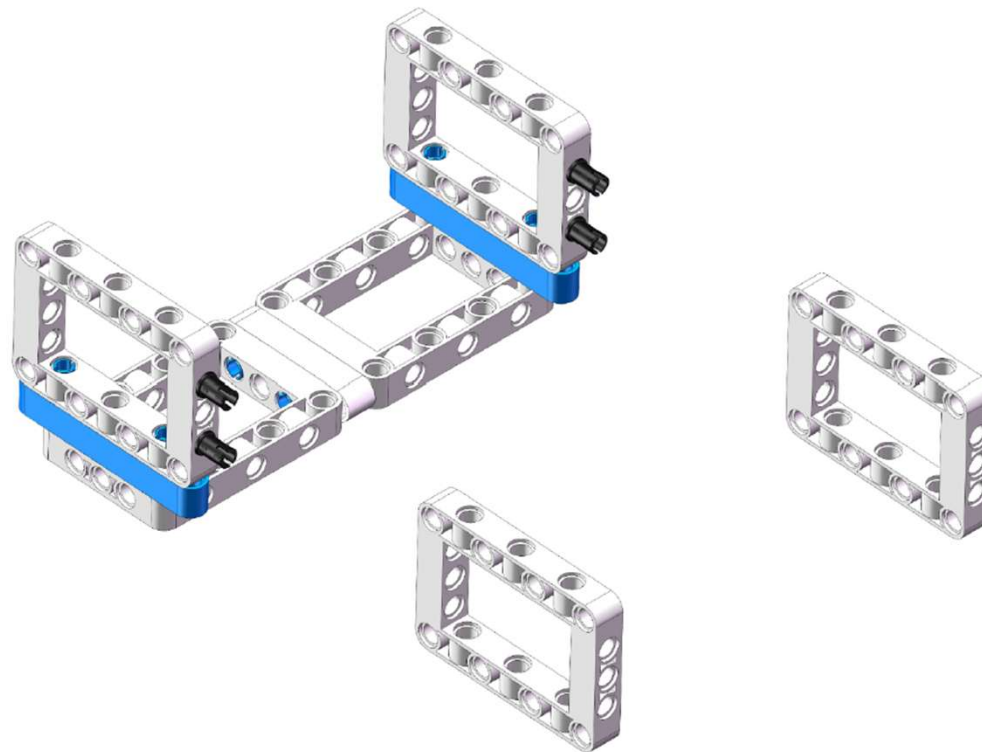

779

Step 27

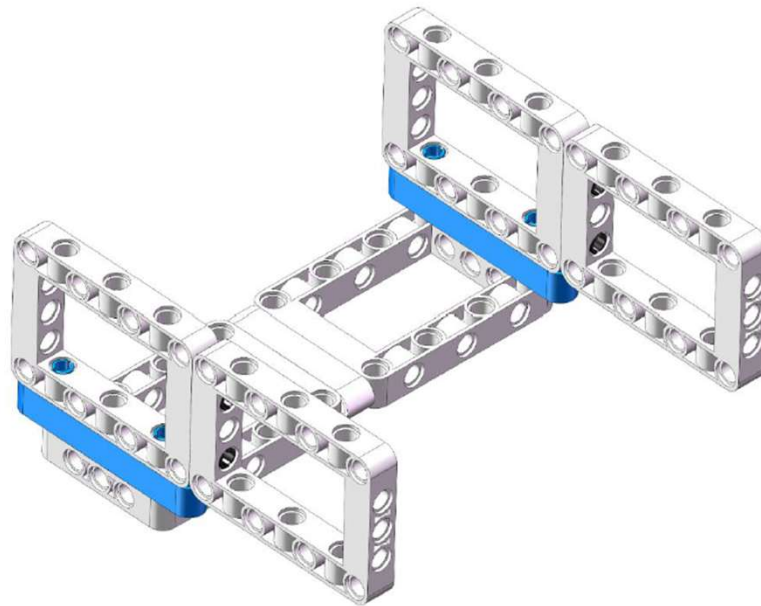

780

Step 28

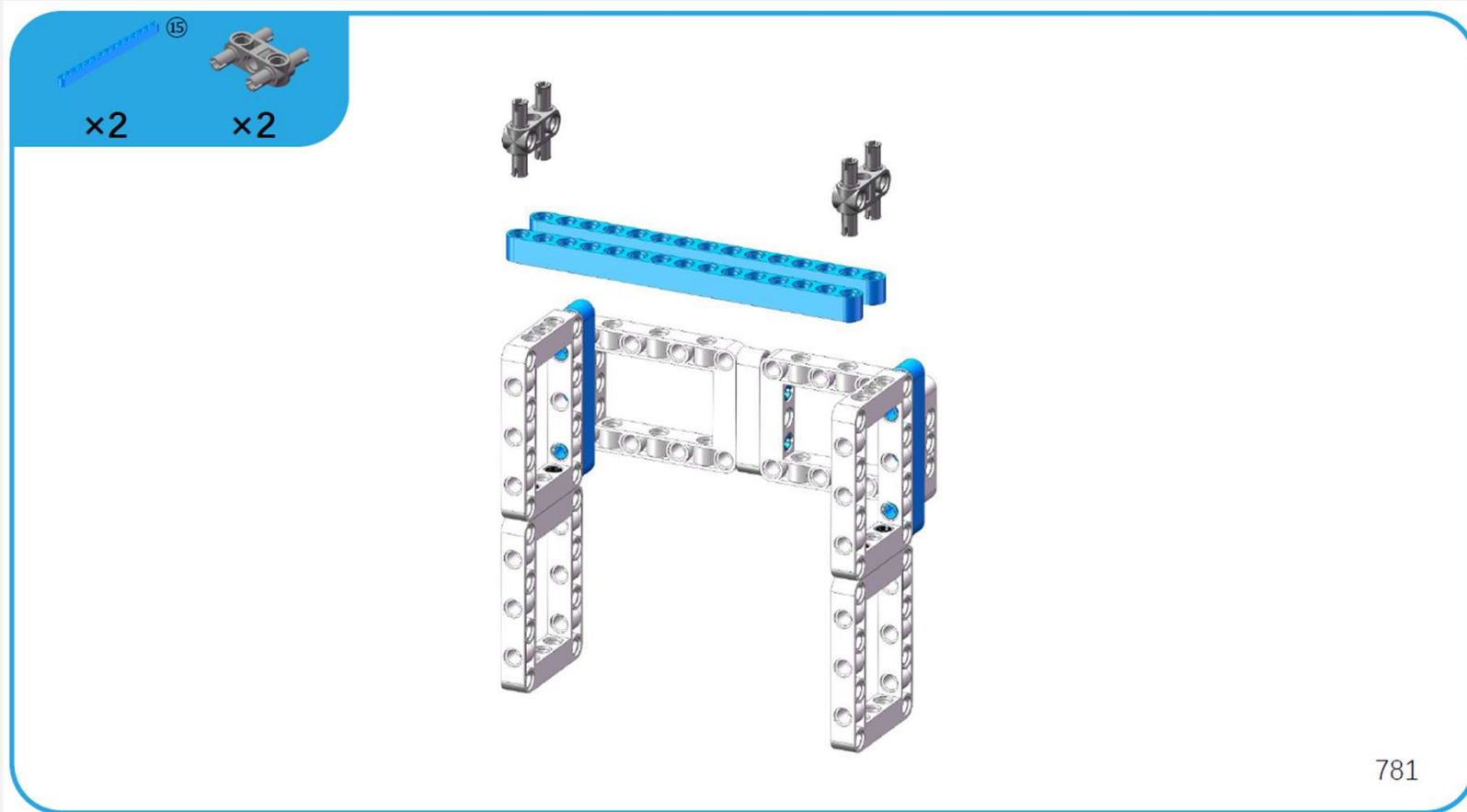

Step 29

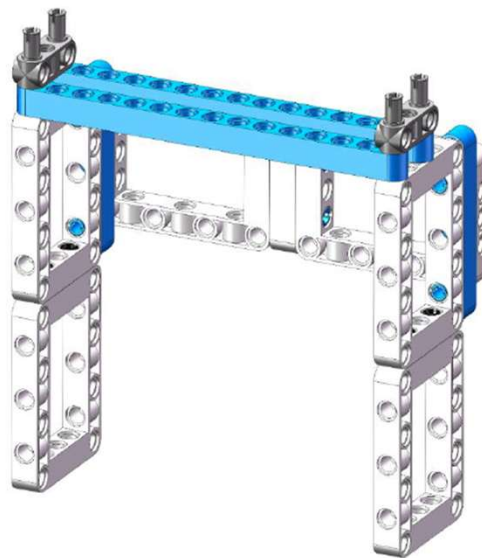

782

Step 30

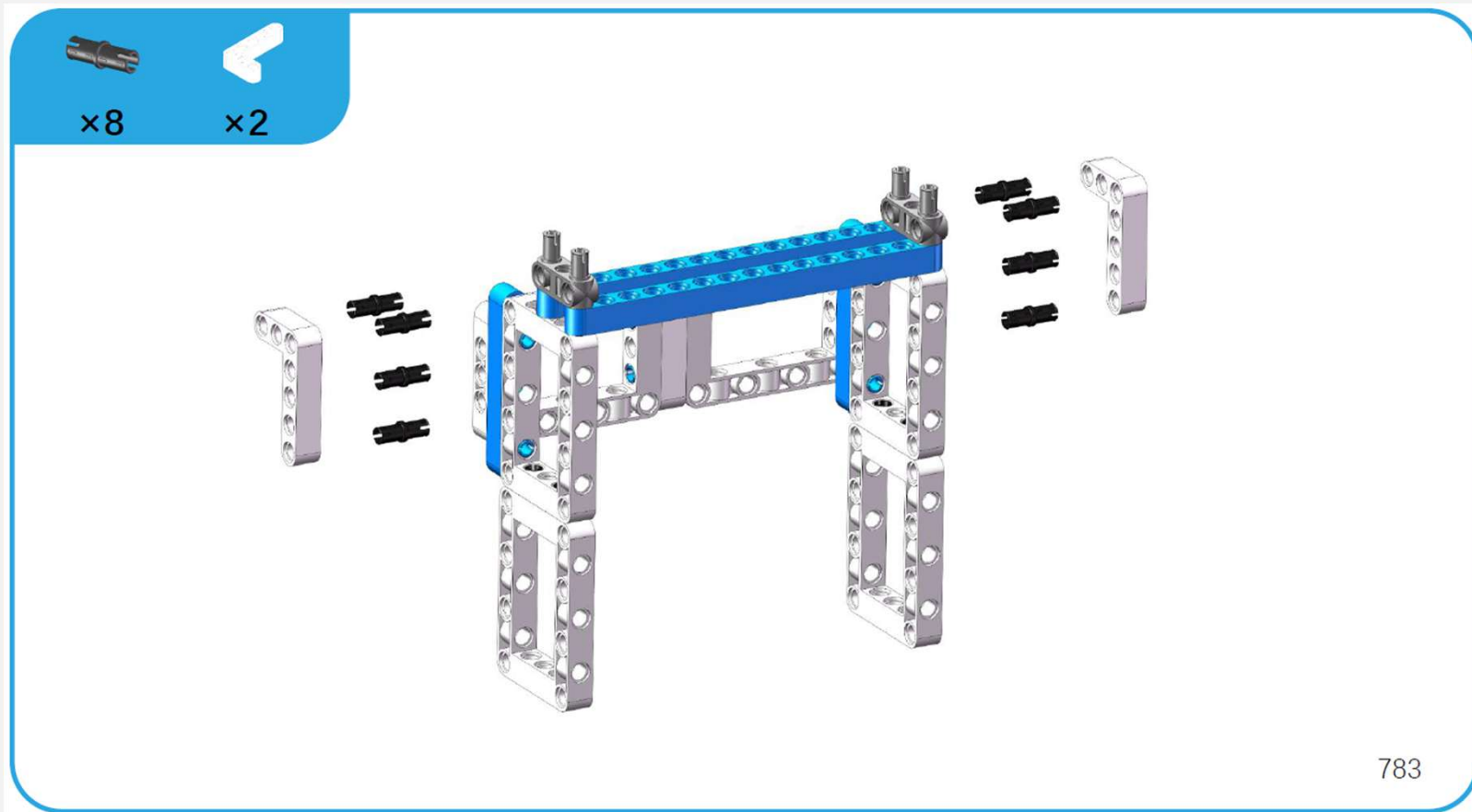

Step 31

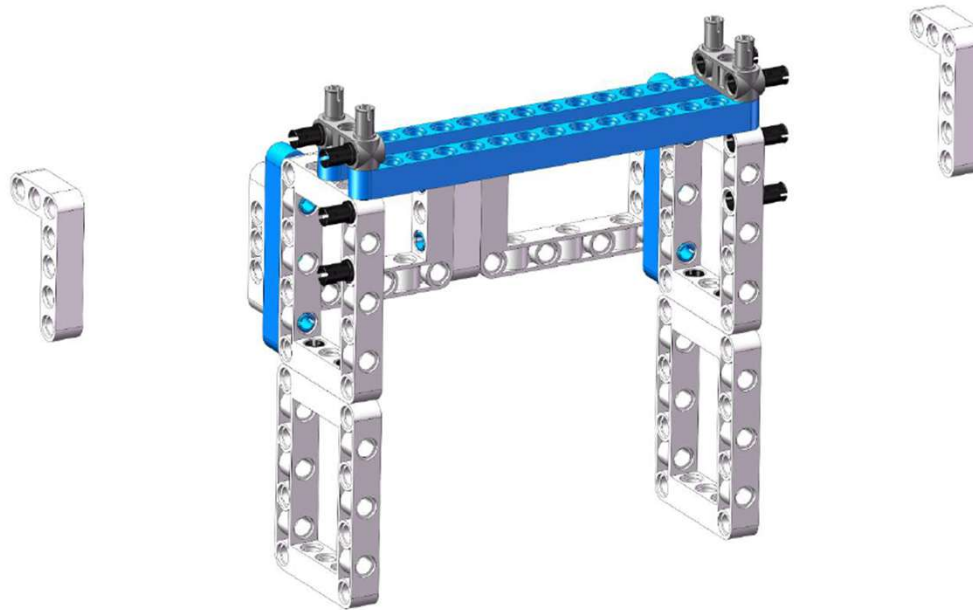

784

Step 32

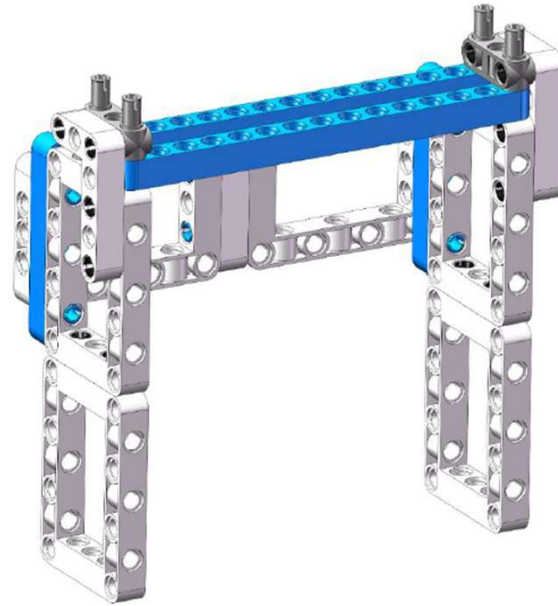

785

Step 33

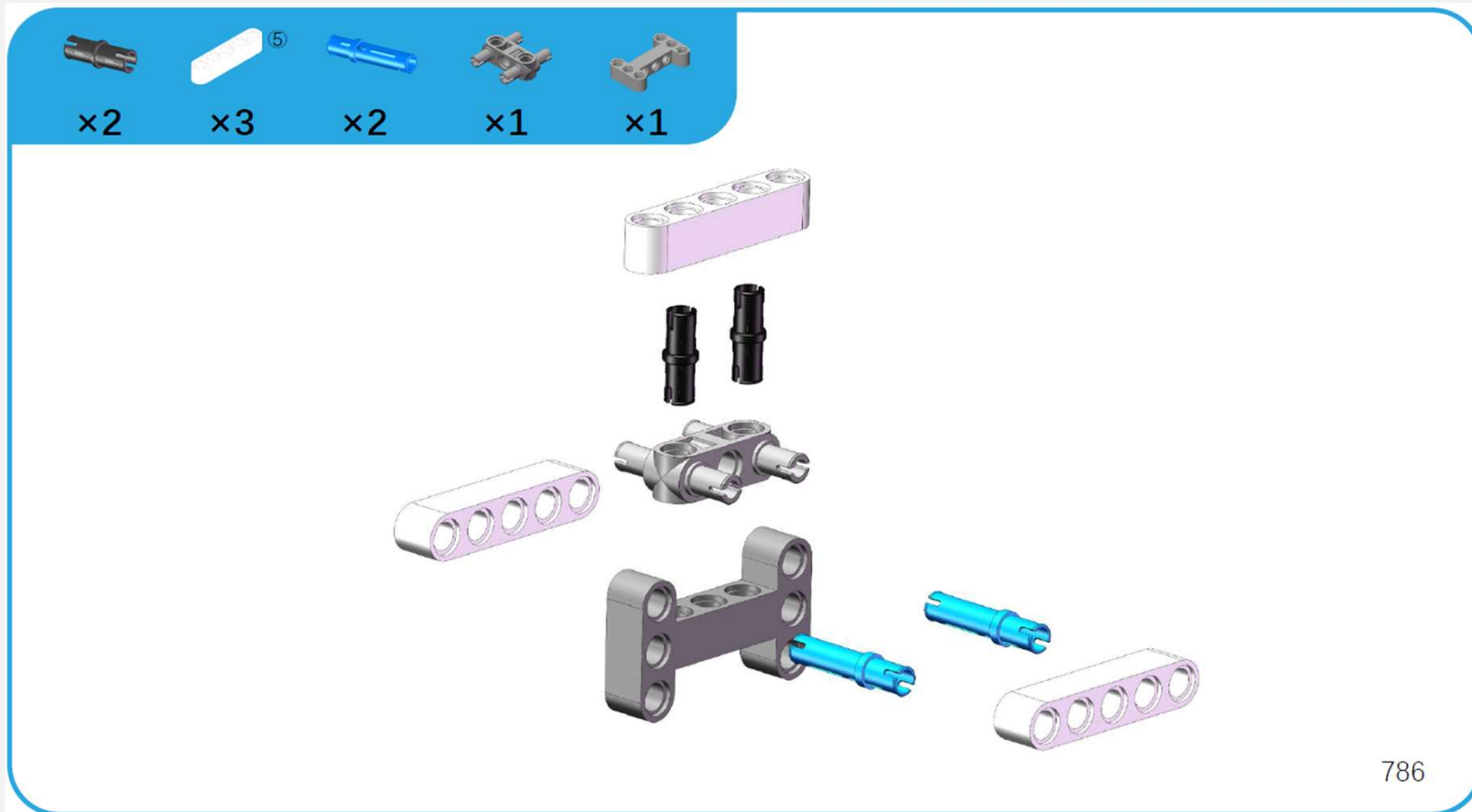

Step 34

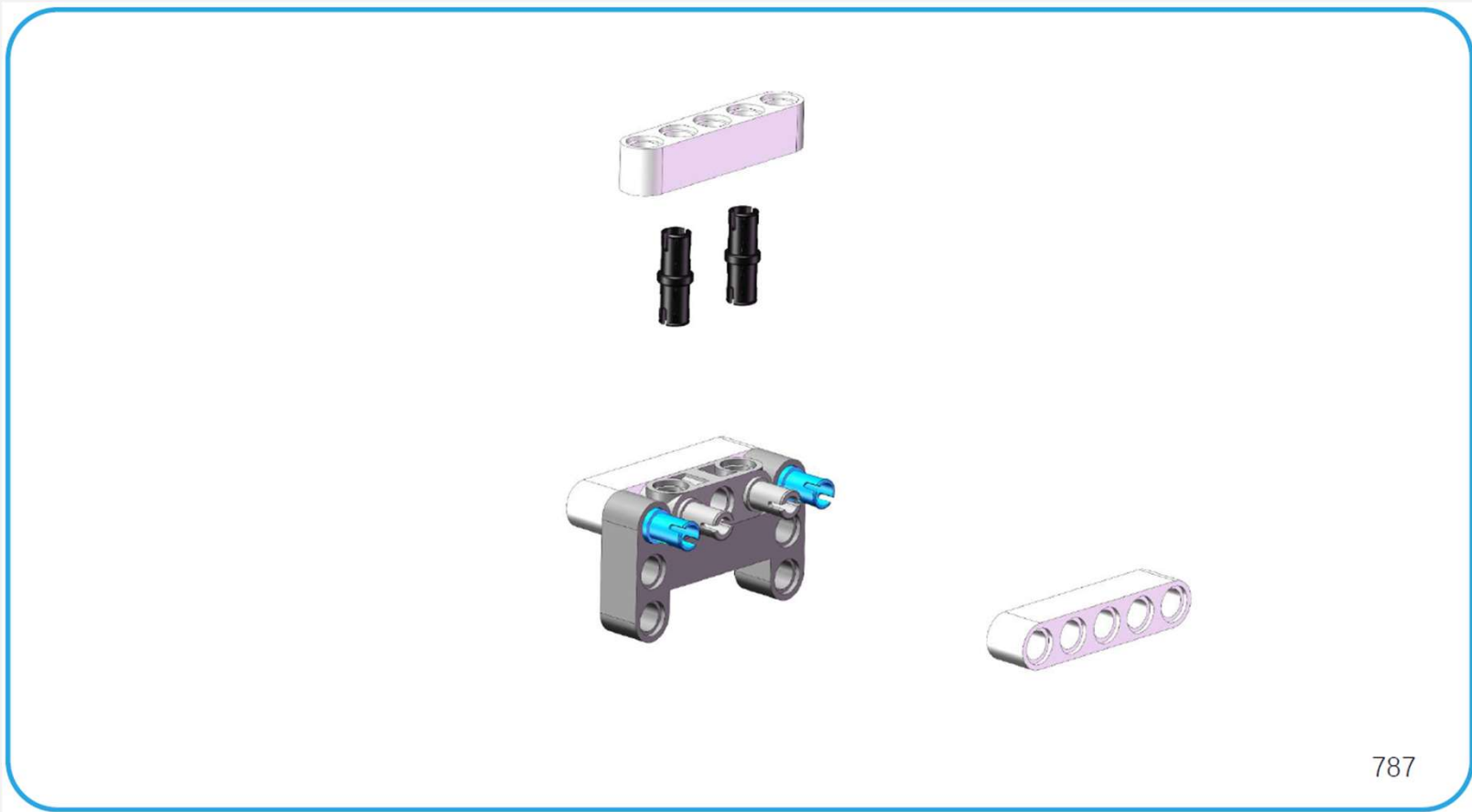

Step 35



788

Step 36



789

Step 37

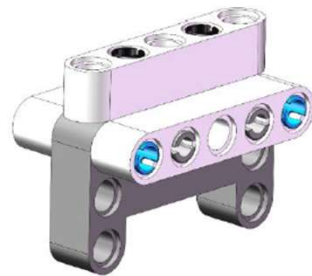

790

Step 38

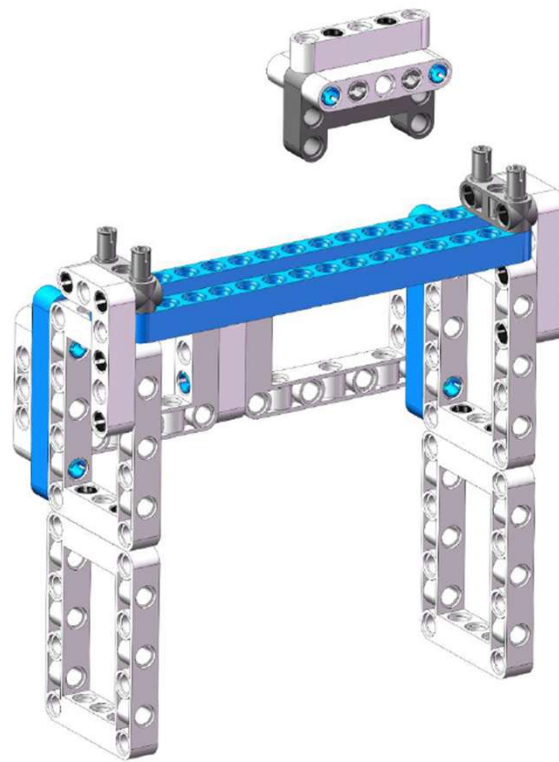

791

Step 39

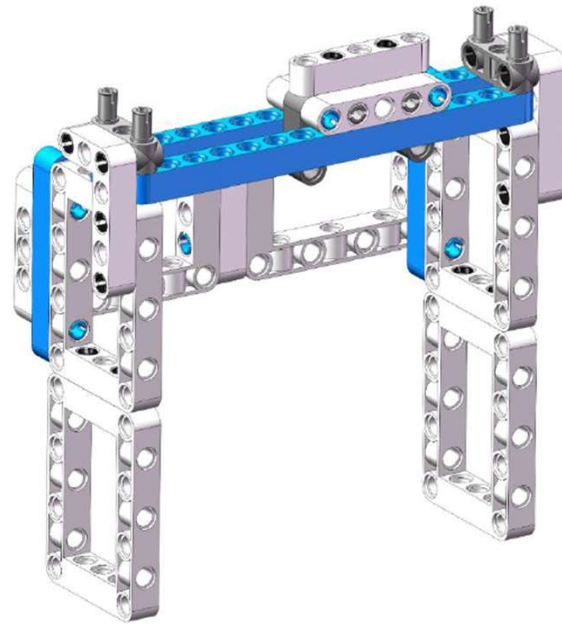

792

Step 40

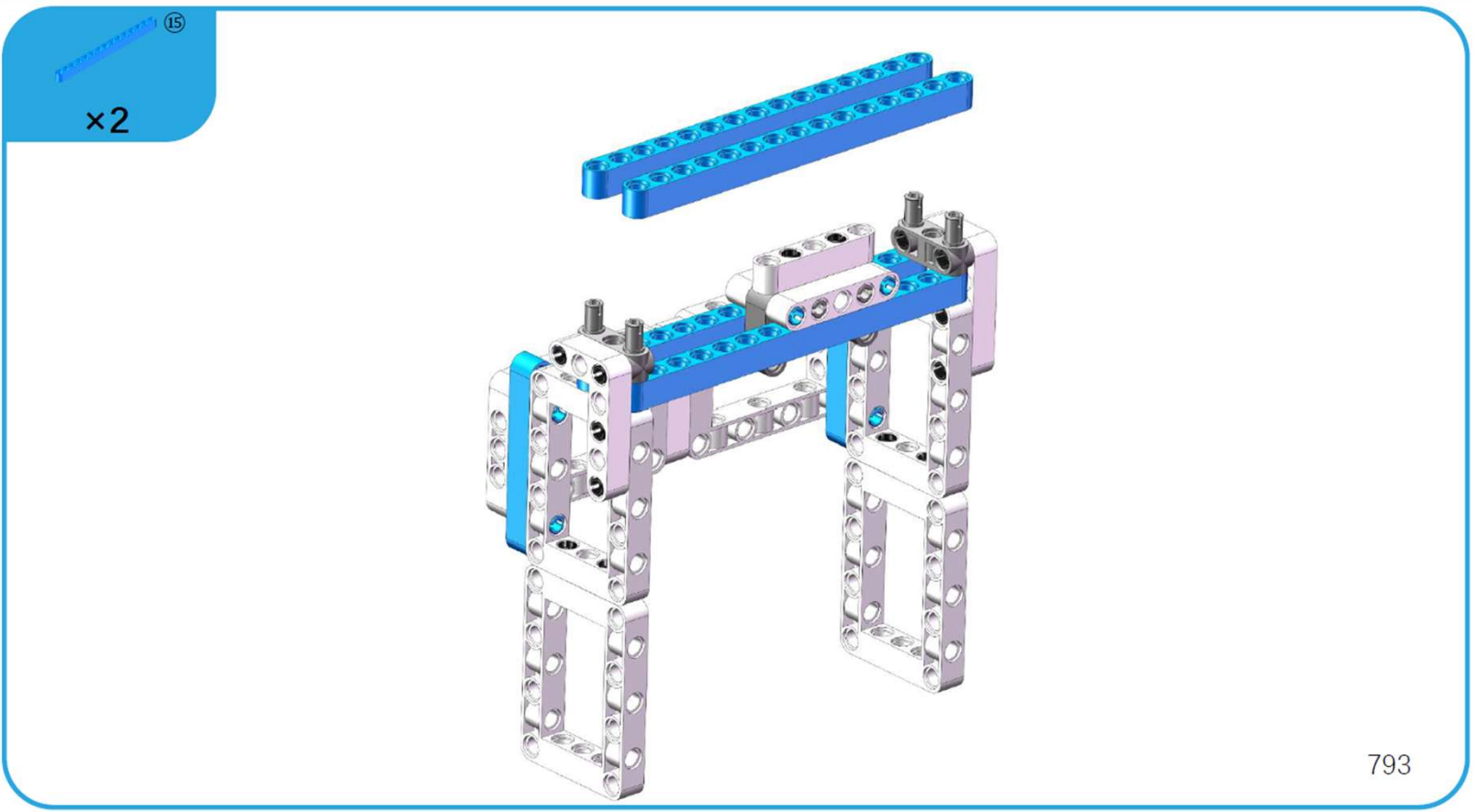

Step 41

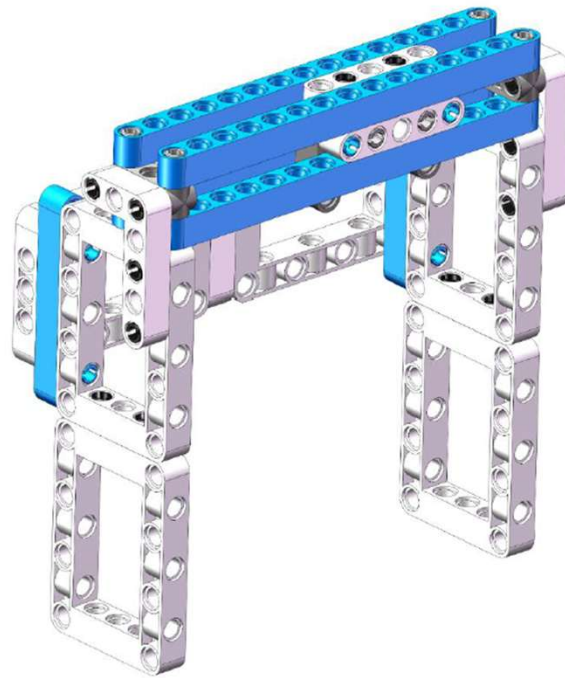

794

Step 42

x4 x4 x2 x2 x1

795

Step 43

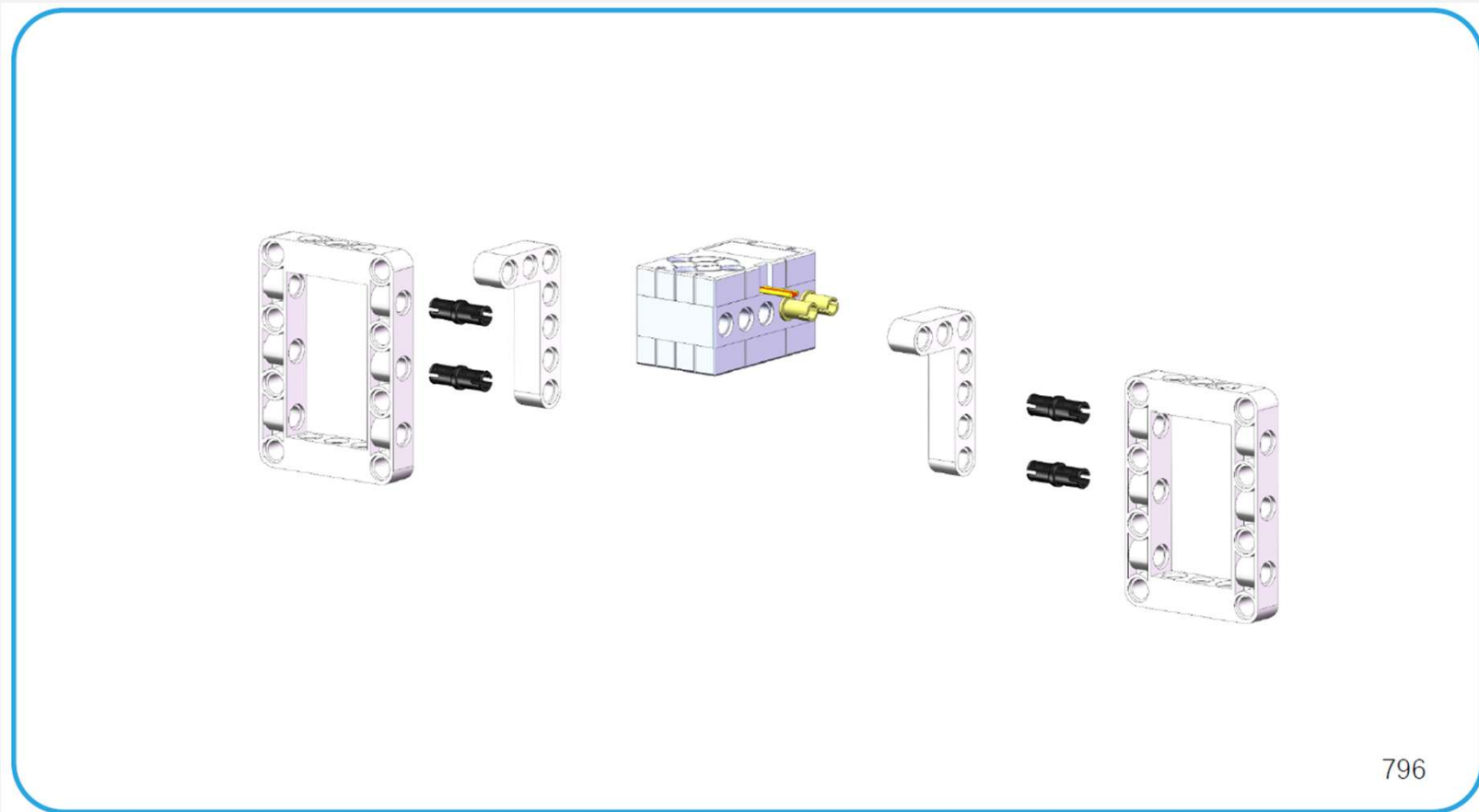

796

Step 44

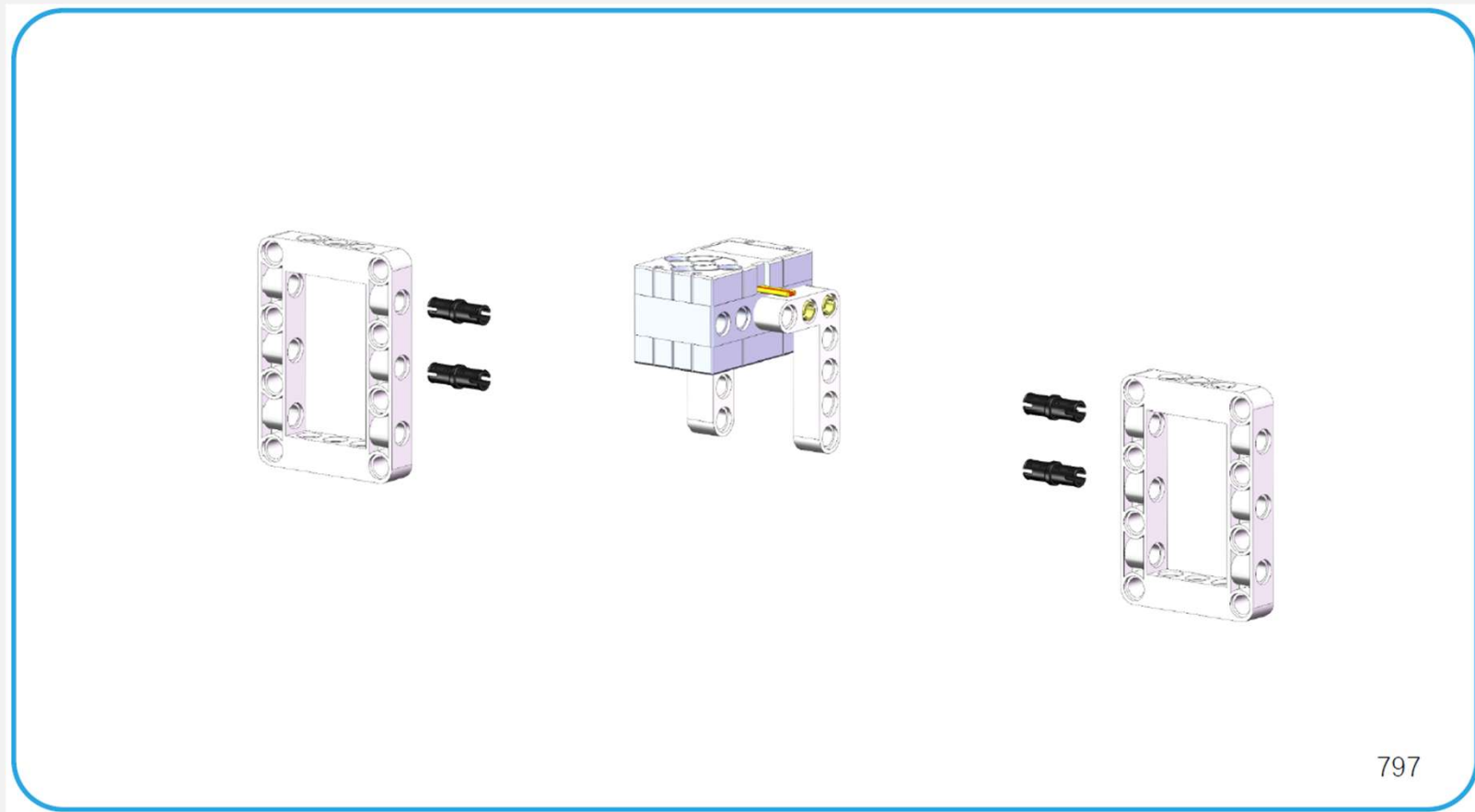

797

Step 45

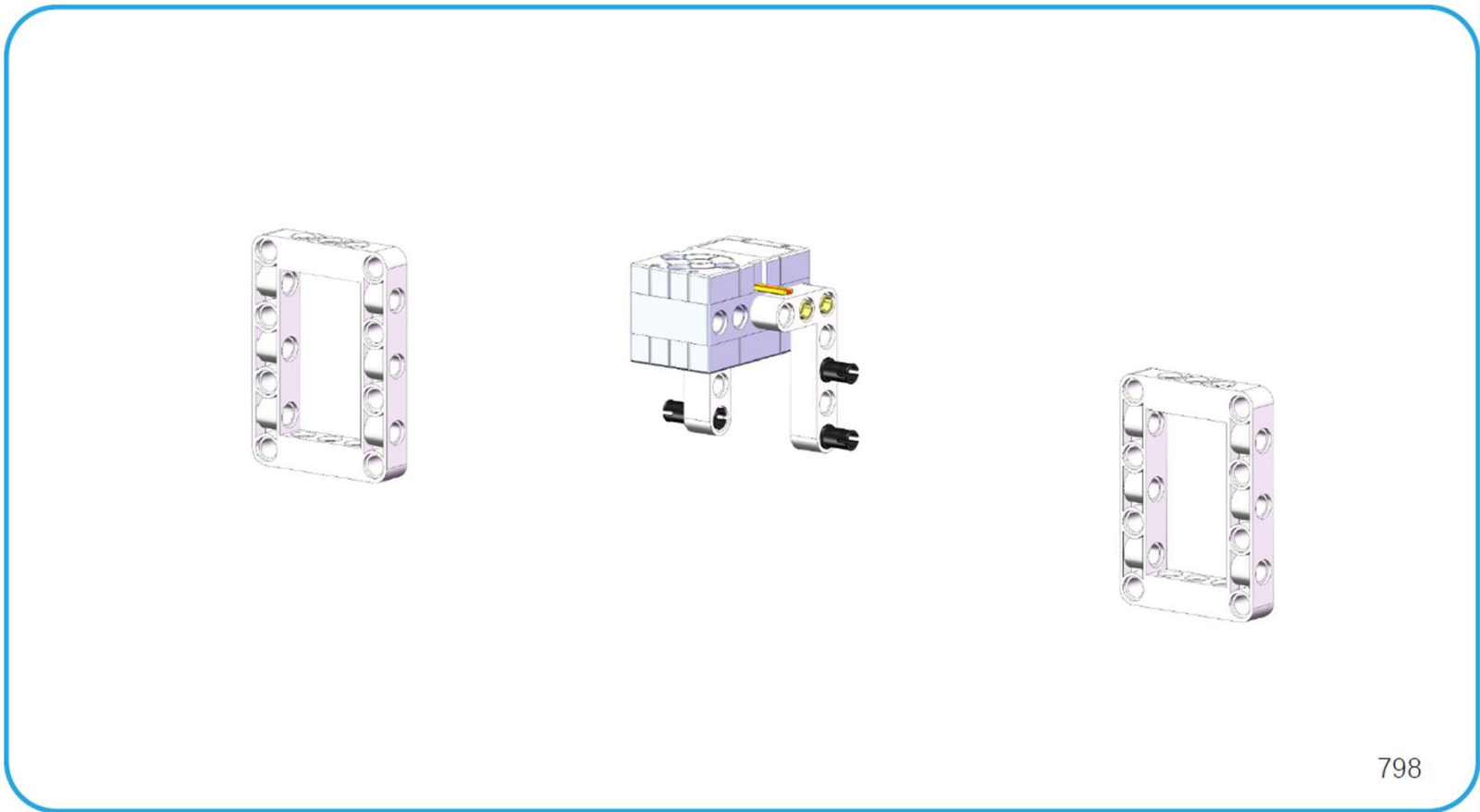

798

Step 46

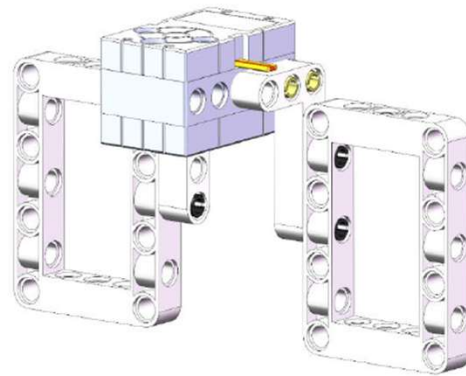

799

Step 47



x4

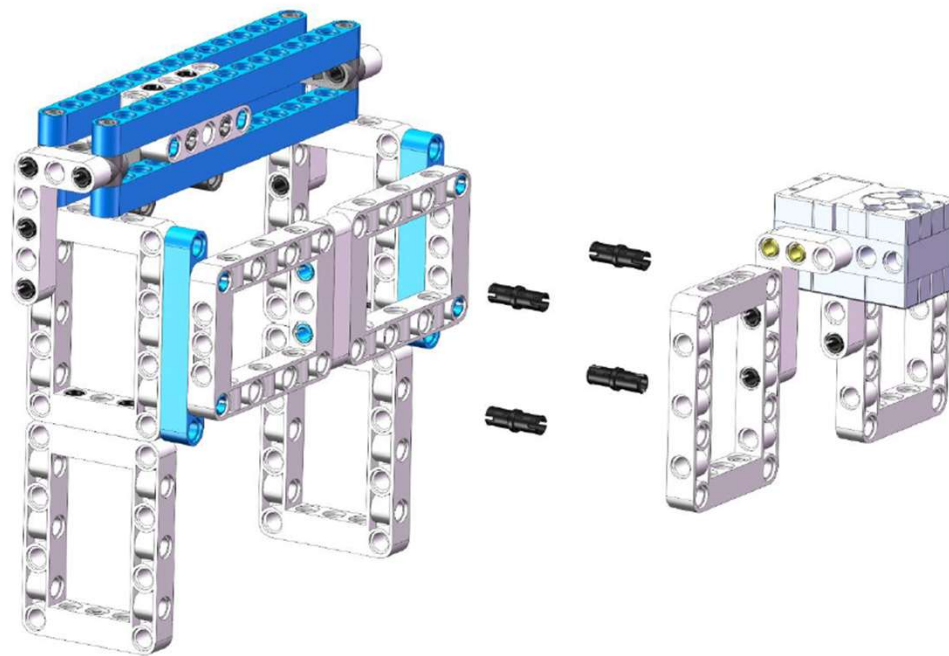

800

Step 48

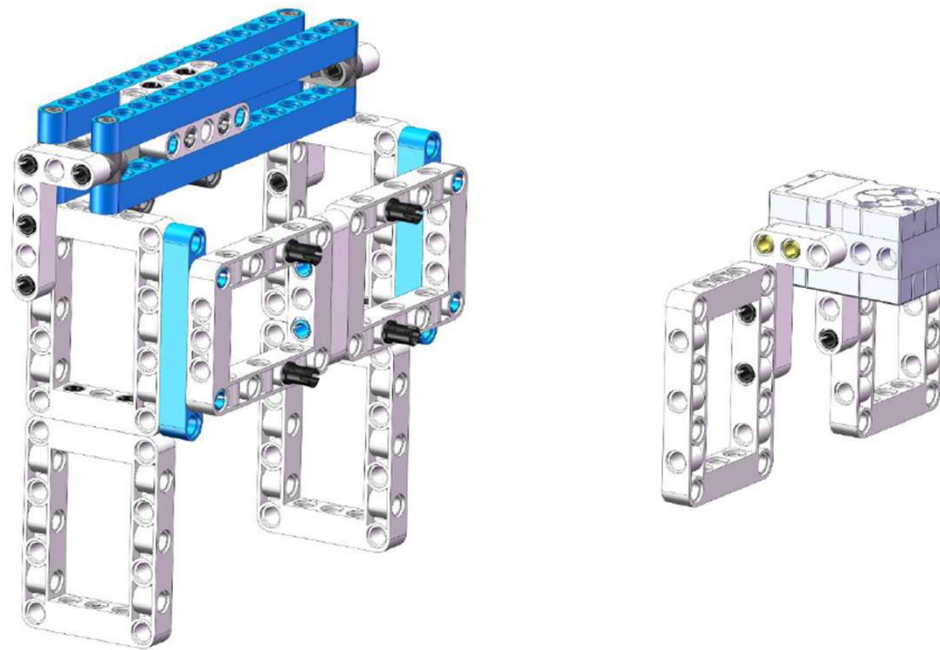

801

Step 49

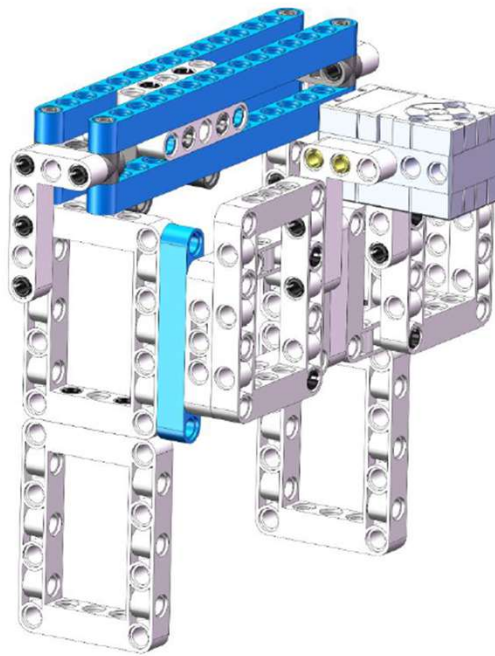

802

Step 50

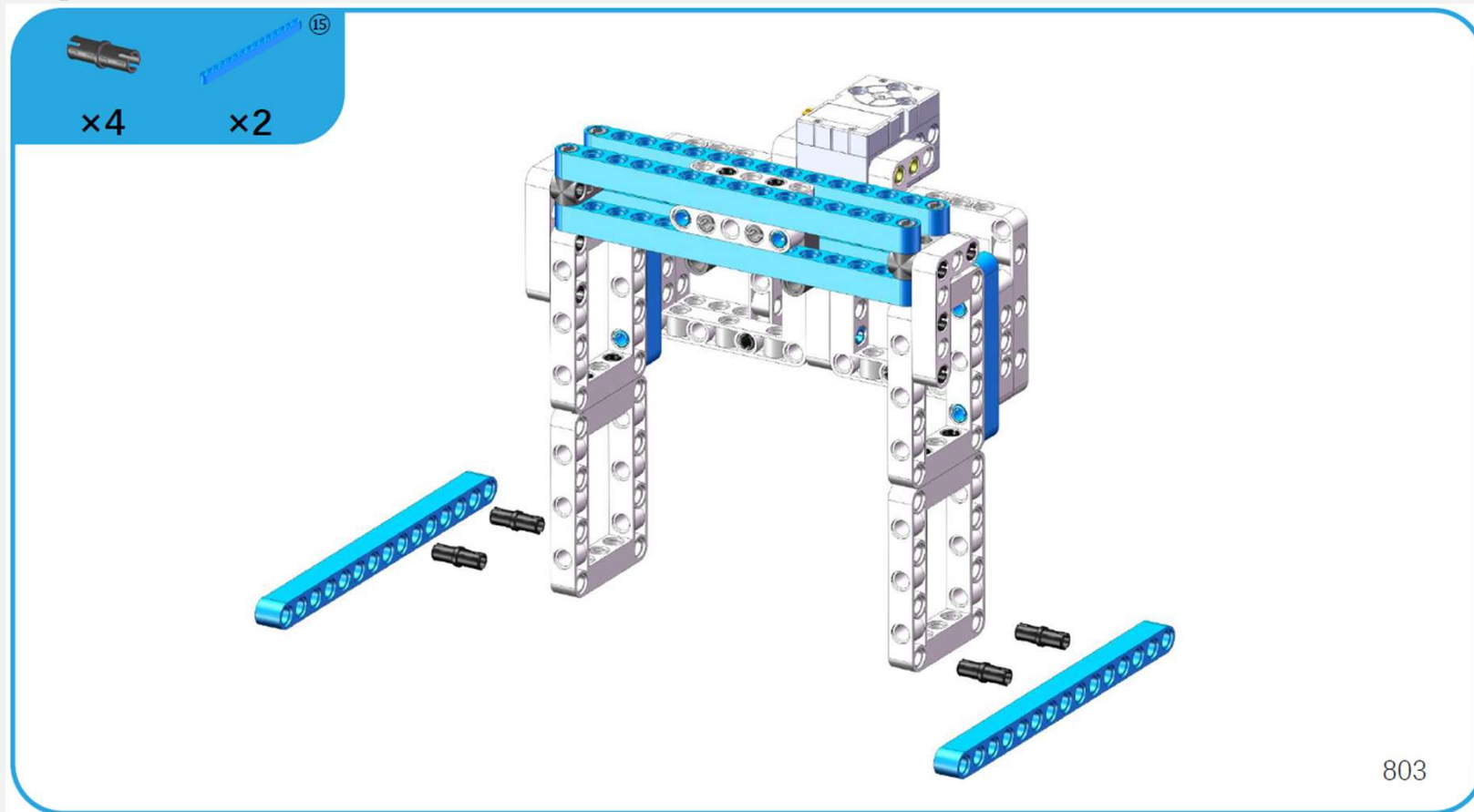

Step 51

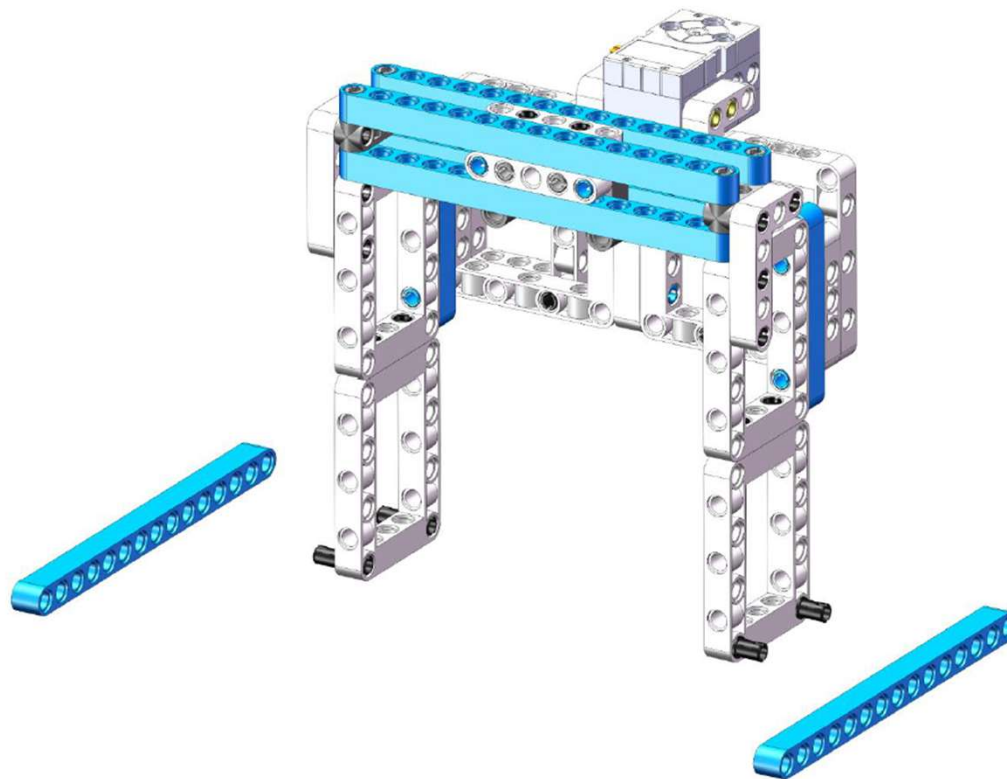

804

Step 52

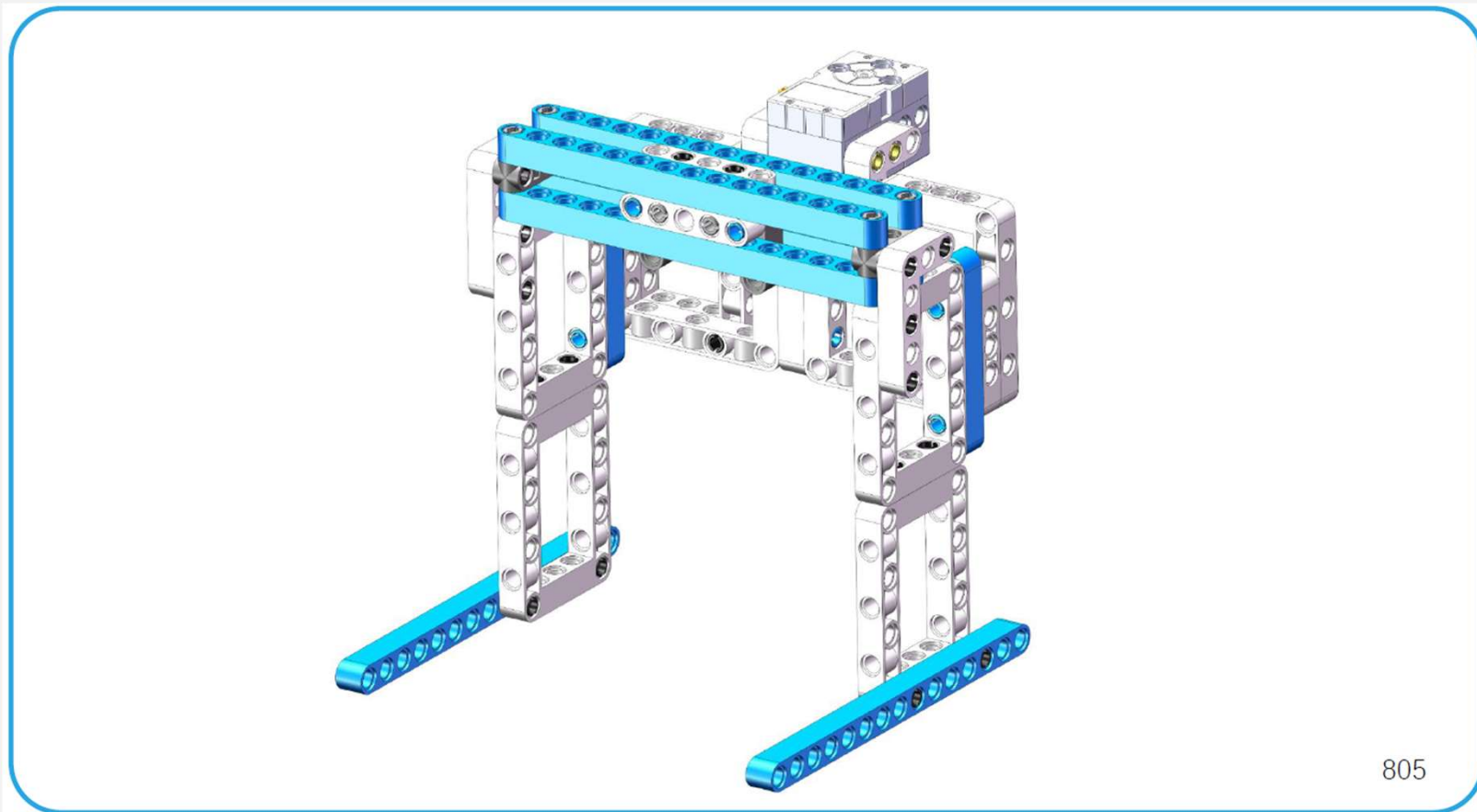

Step 53

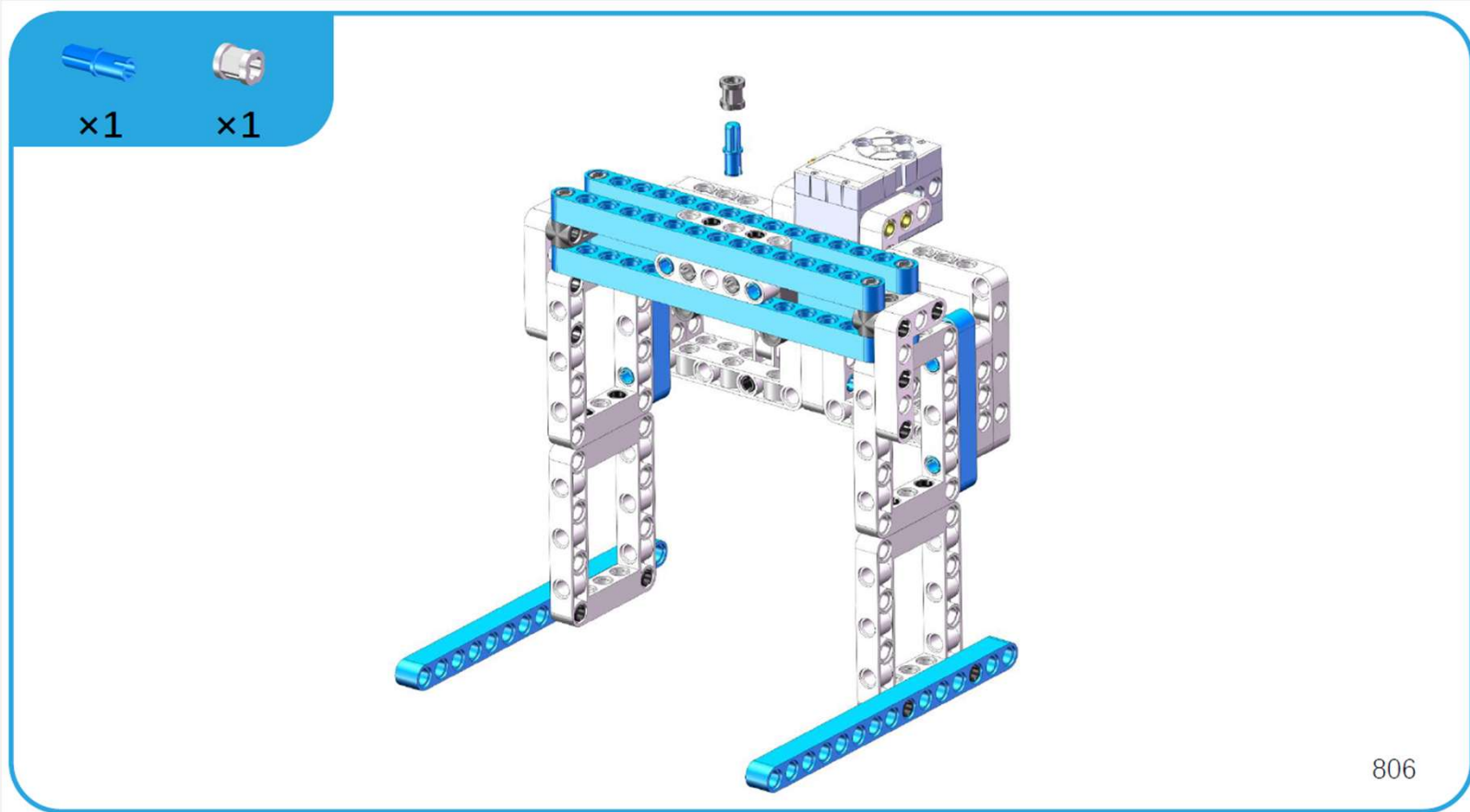

Step 54

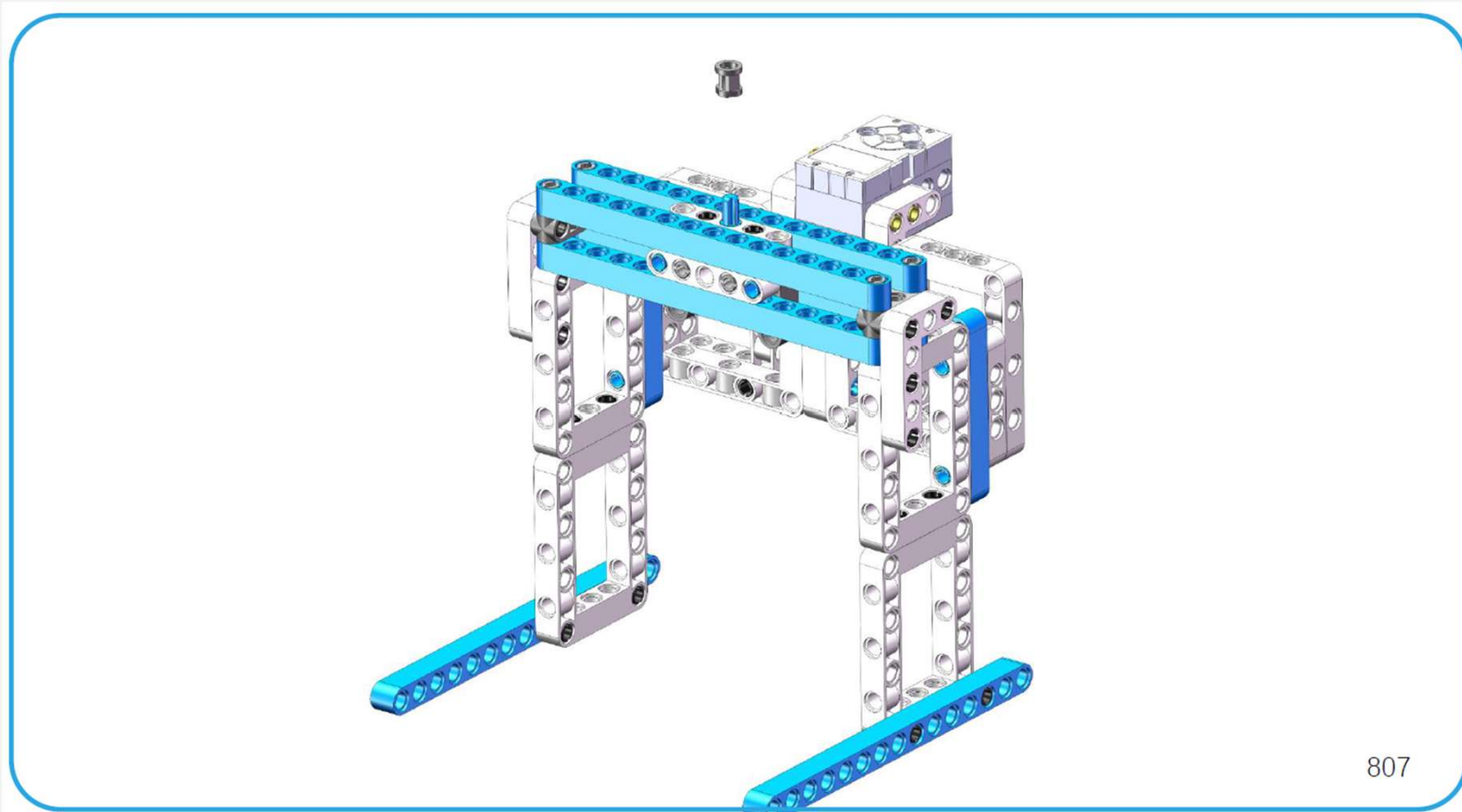

Step 55

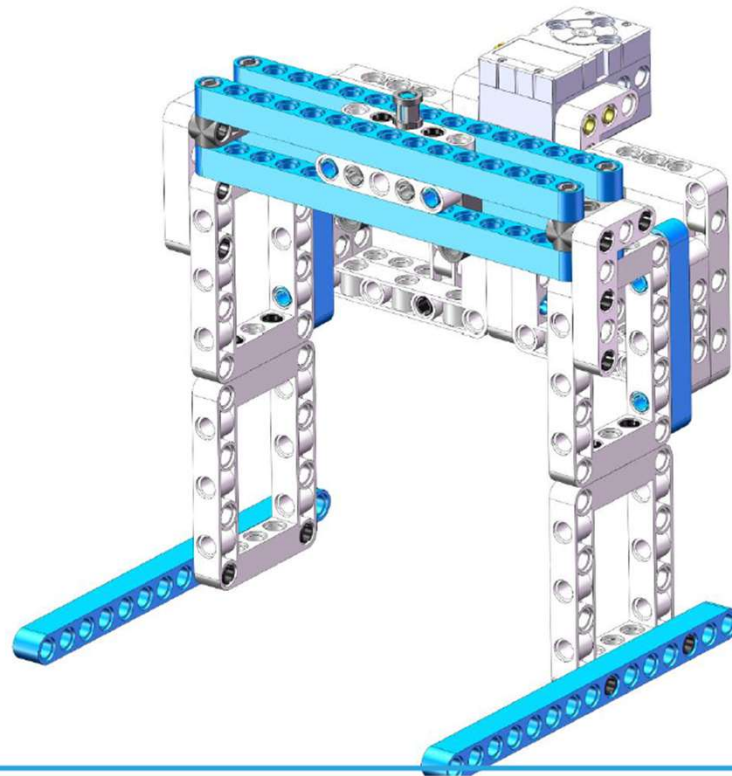

808

Step 56

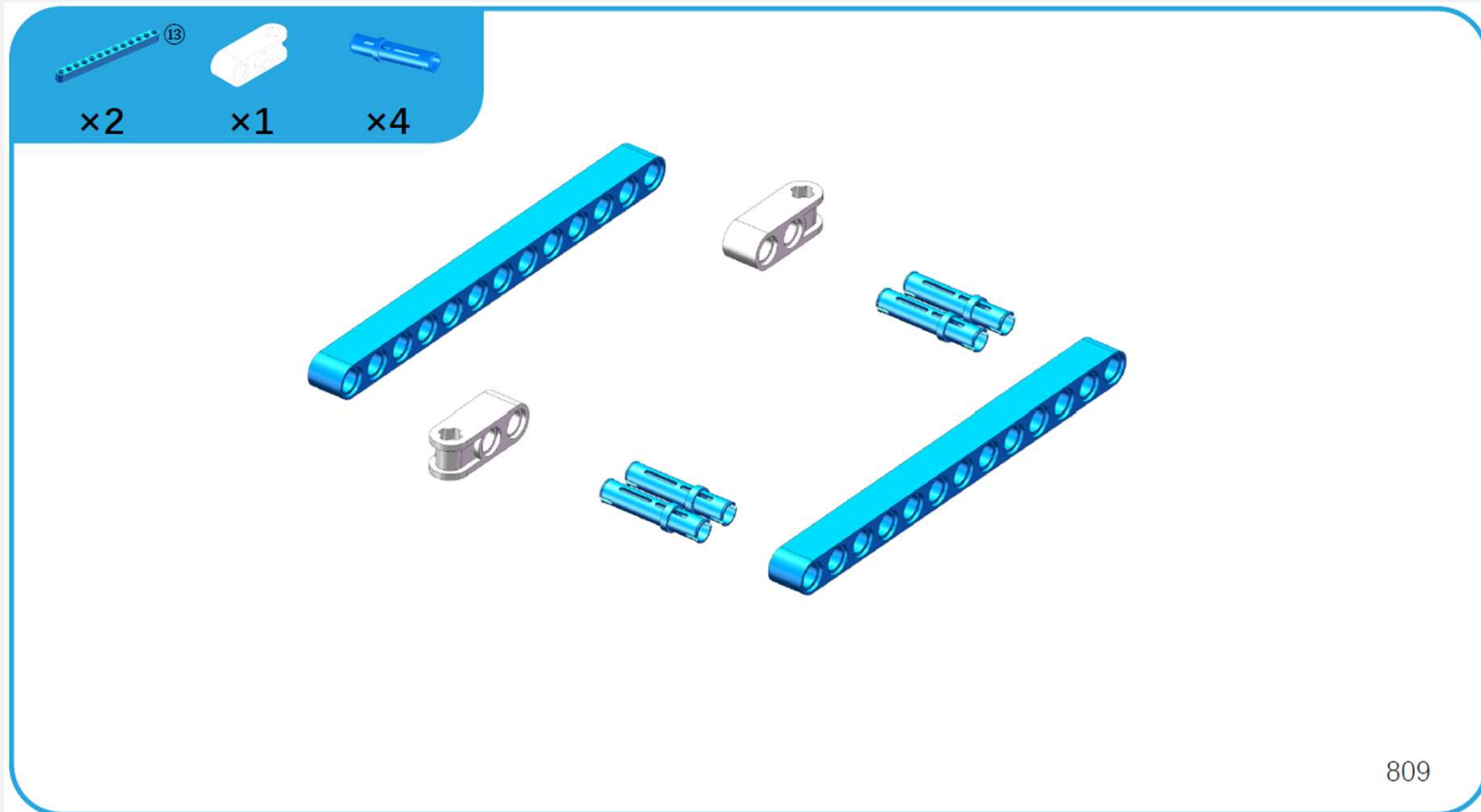

Step 57

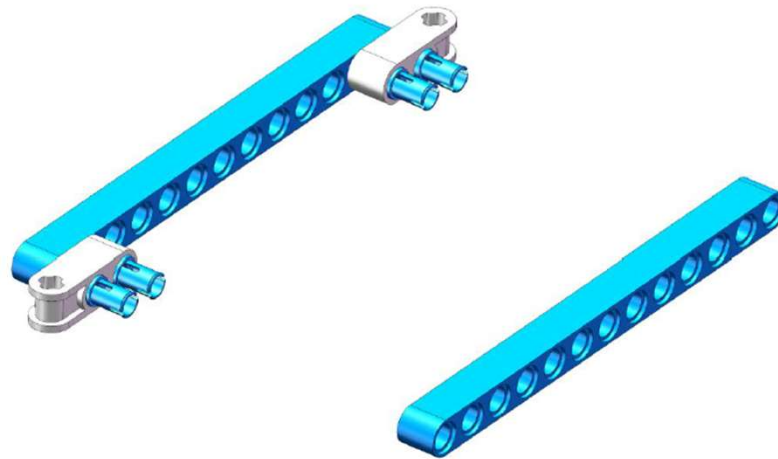

810

Step 58

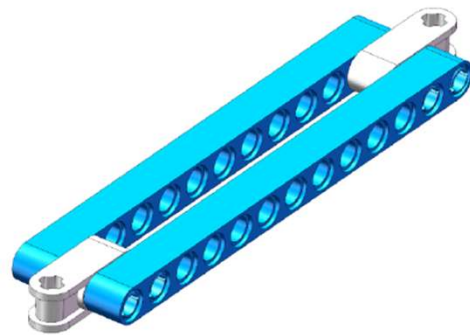

811

Step 58 – Set Servo P1

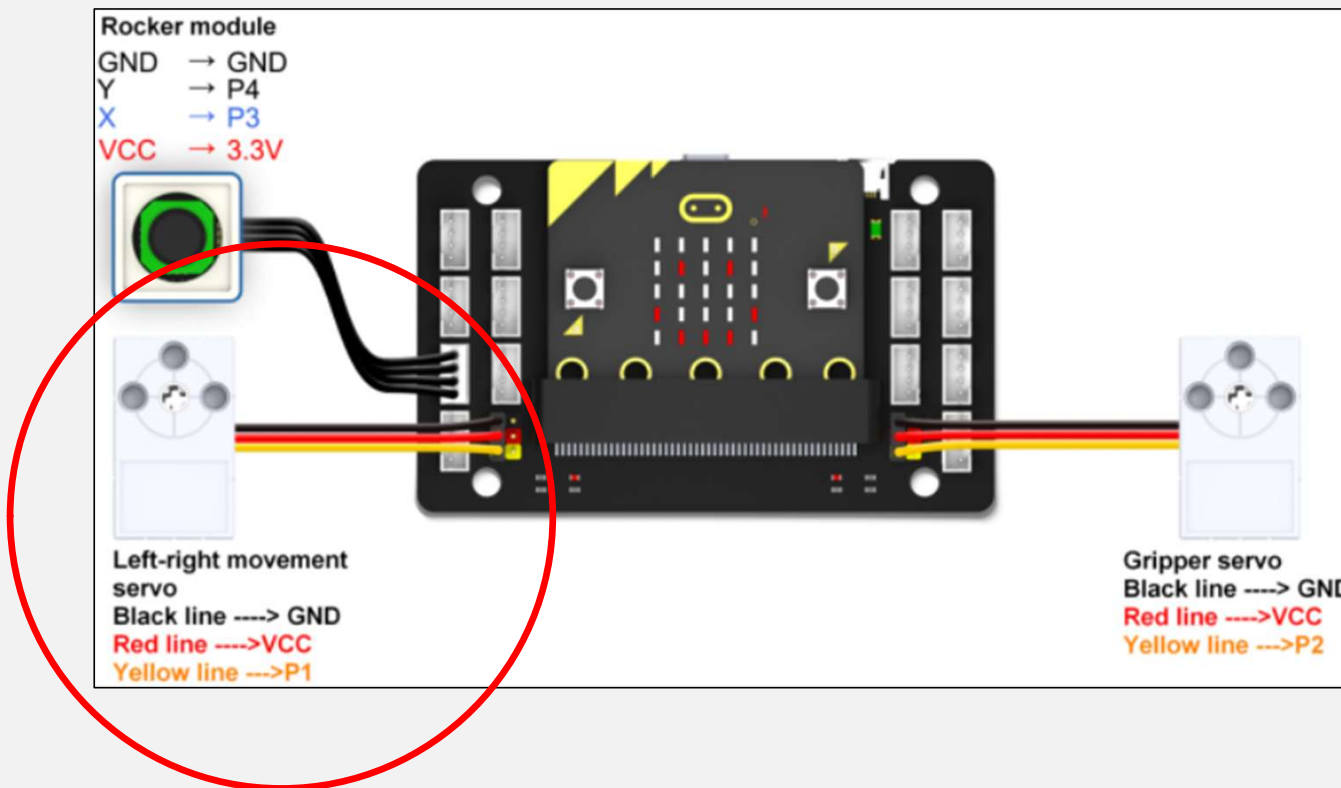

Let's plug in the servo to P1, then we need to set the servo program to make it go to starting position at 180.

Step 58 - Set Servo P1 to middle position

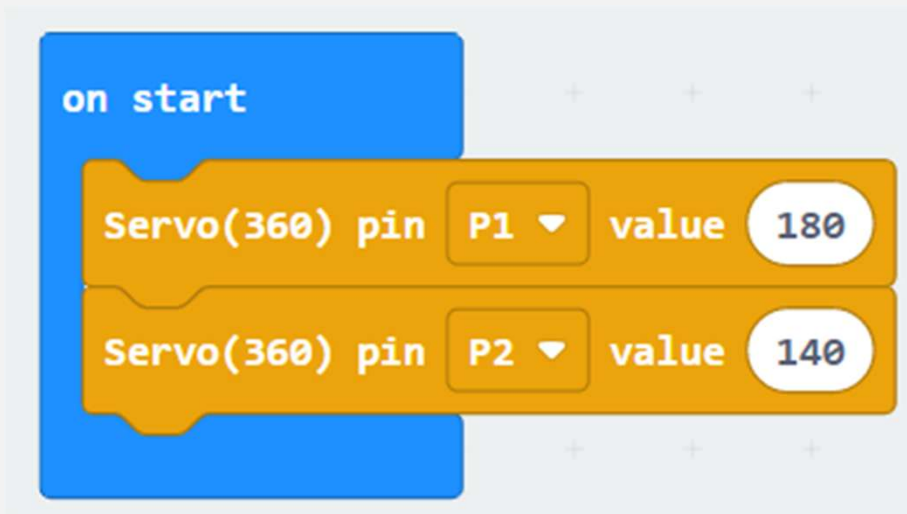

Add in Servo P1 and set the value to 180, then download this script to your microbit.

Step 59

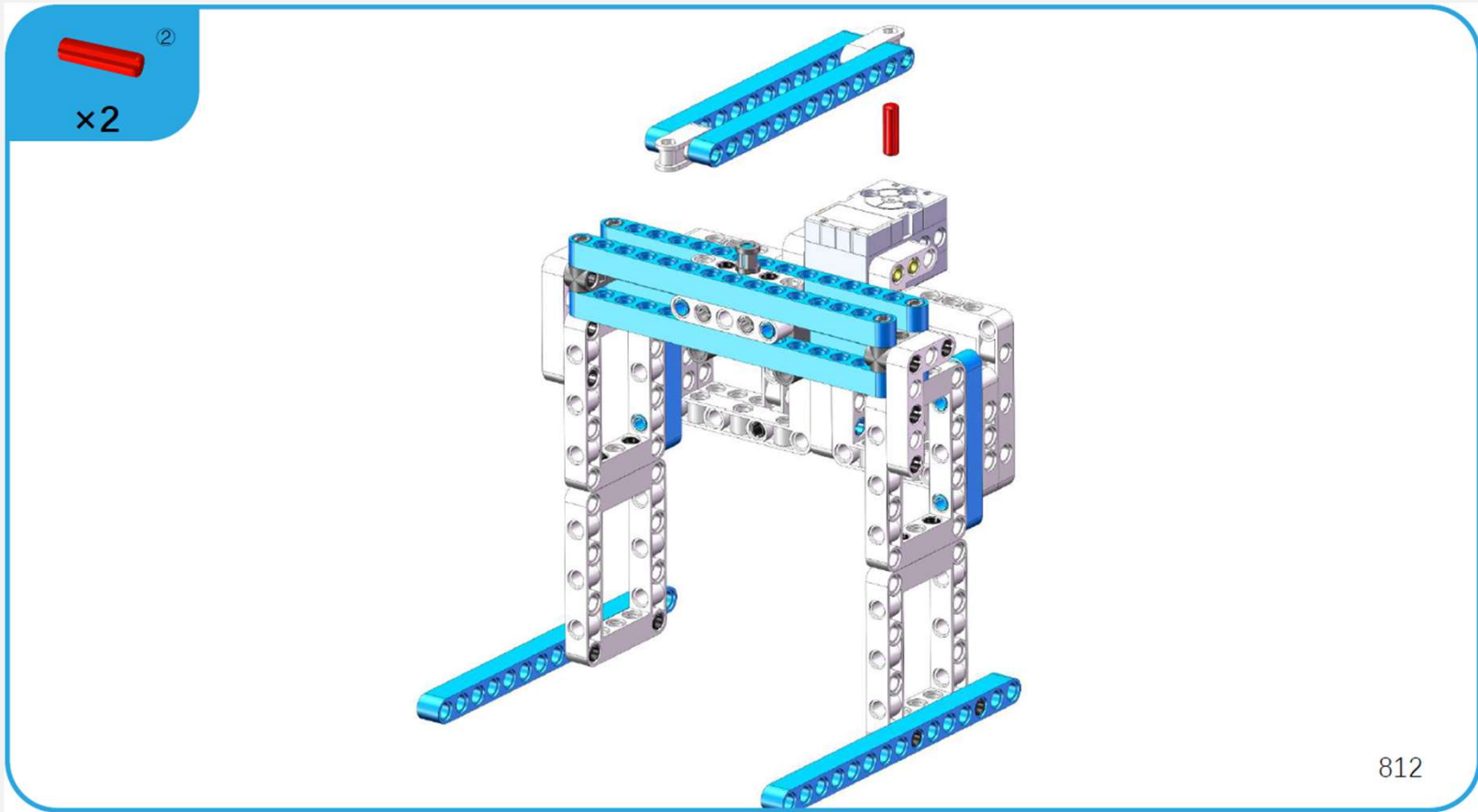

Step 60

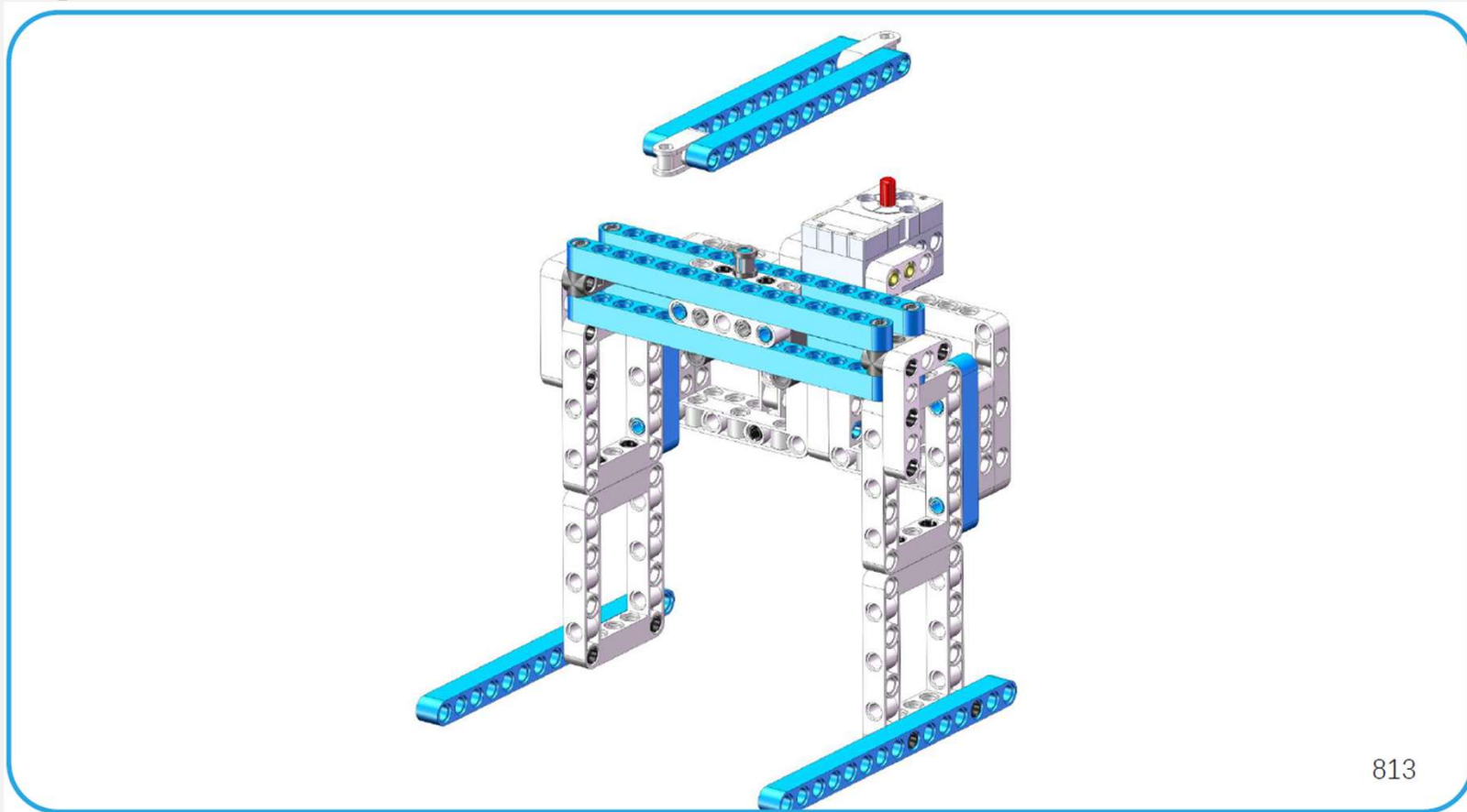

Step 61

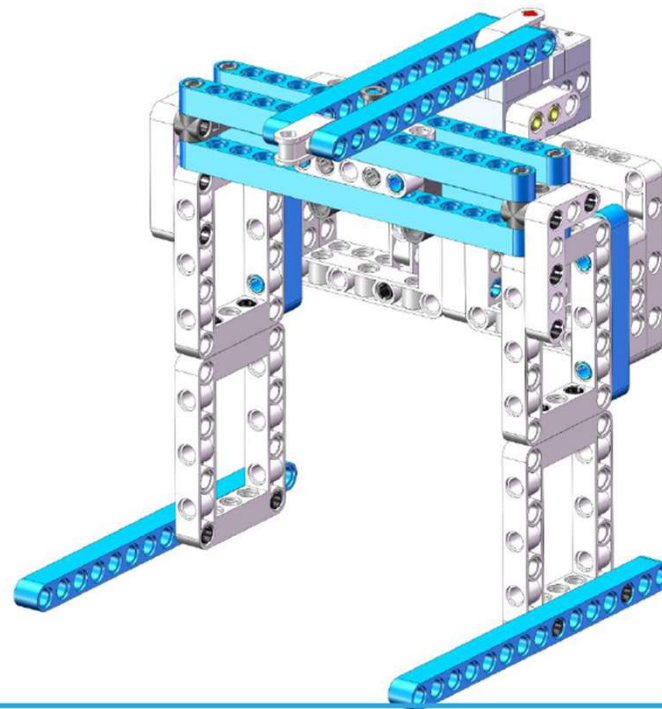

814

Step 62

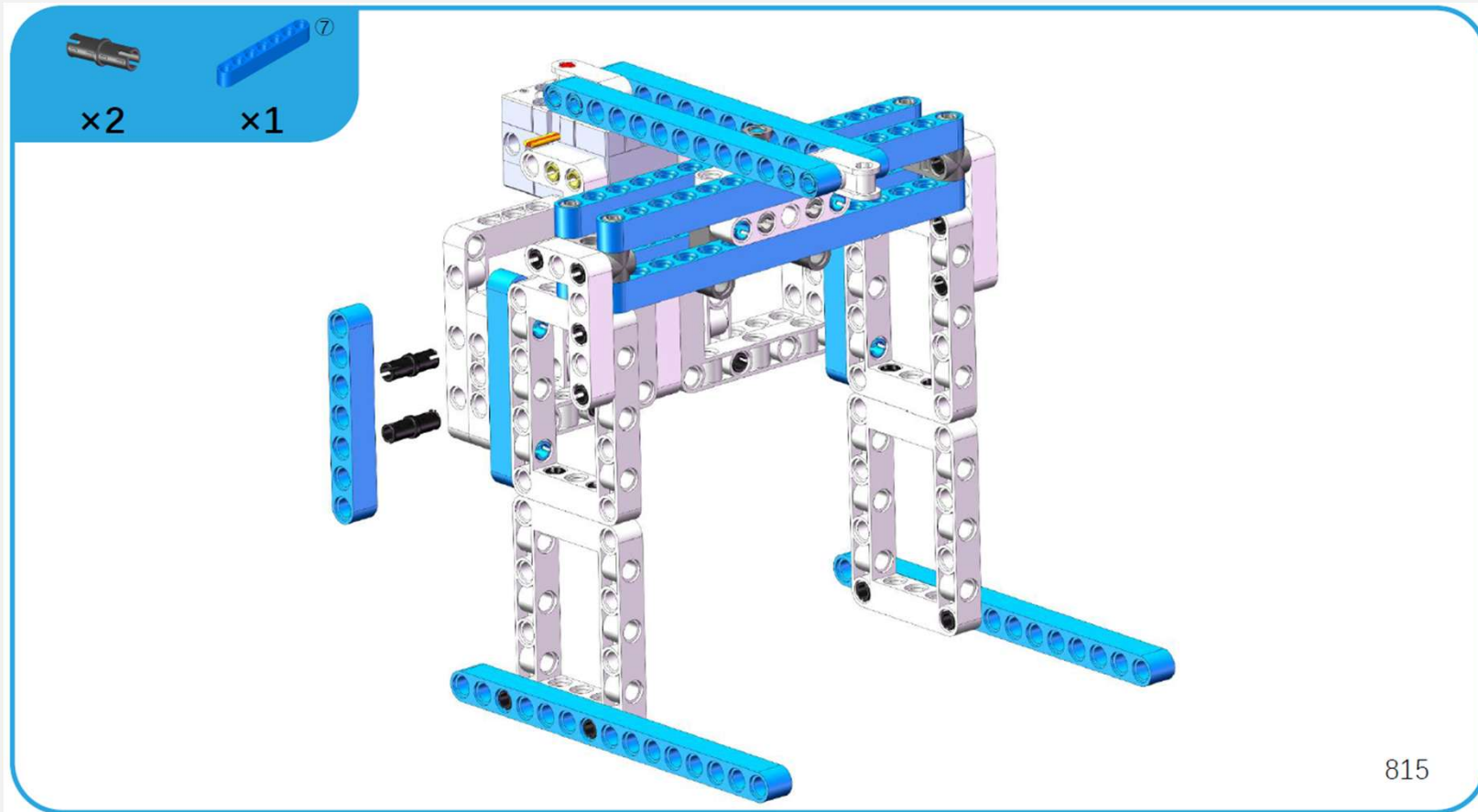

Step 63

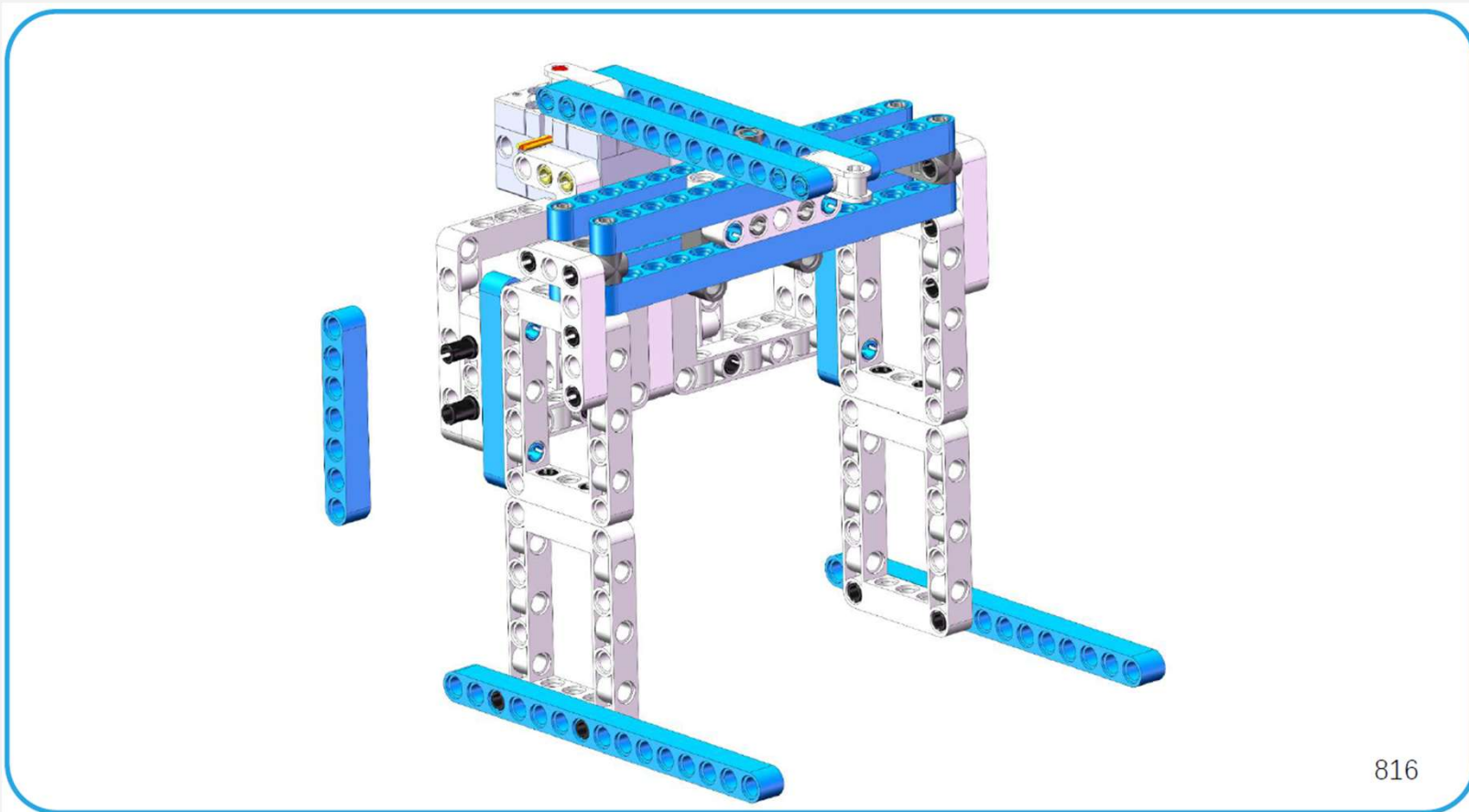

Step 64

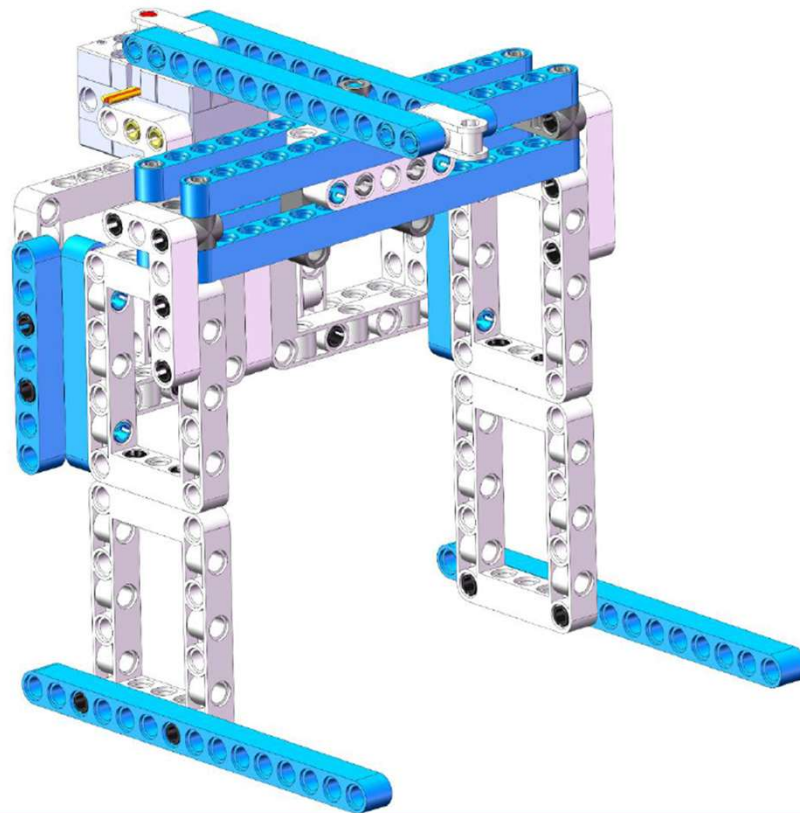

817

Step 65

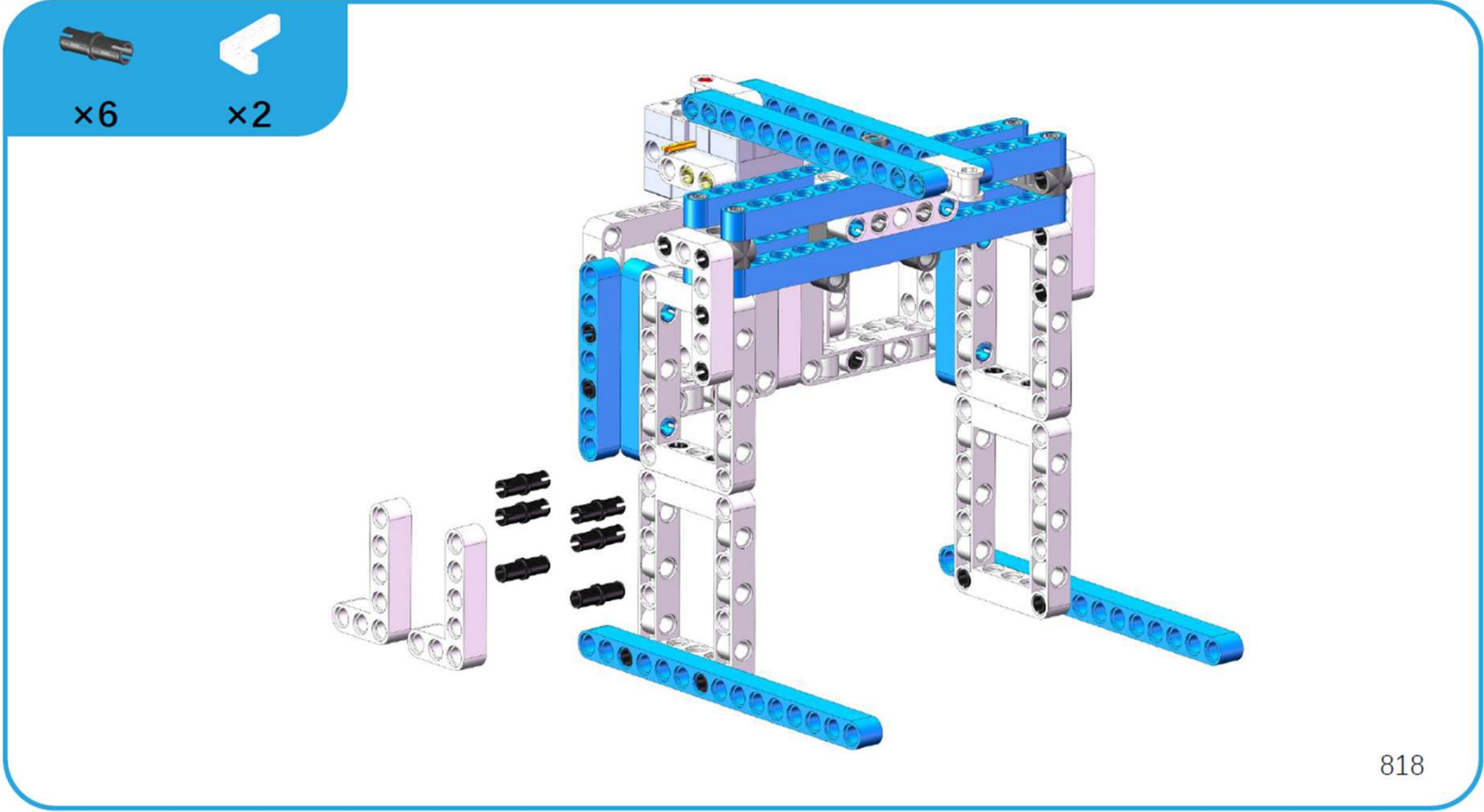

Step 66

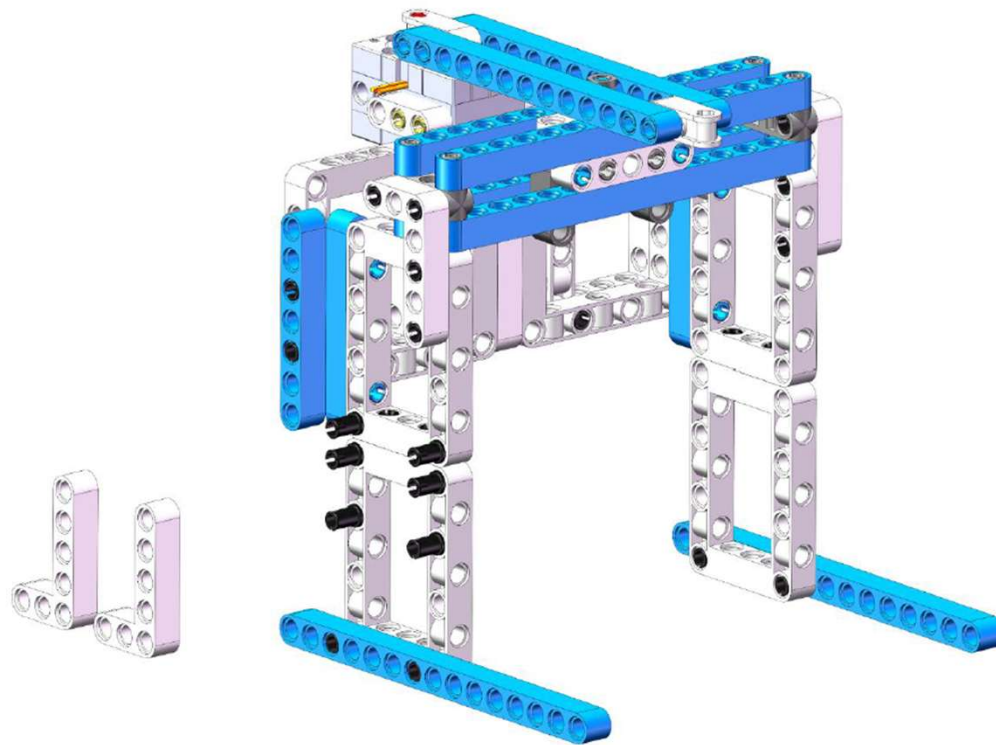

819

Step 67

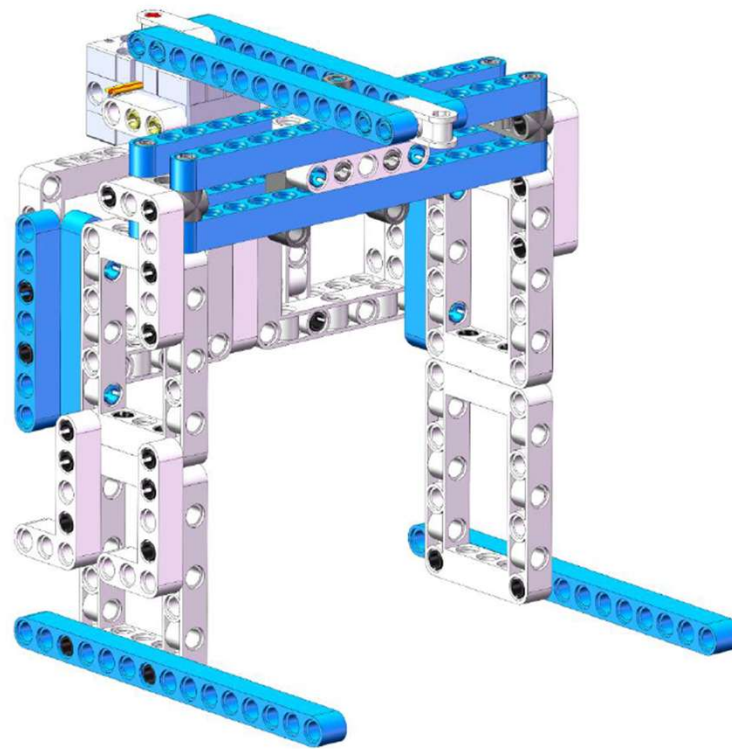

820

Step 68

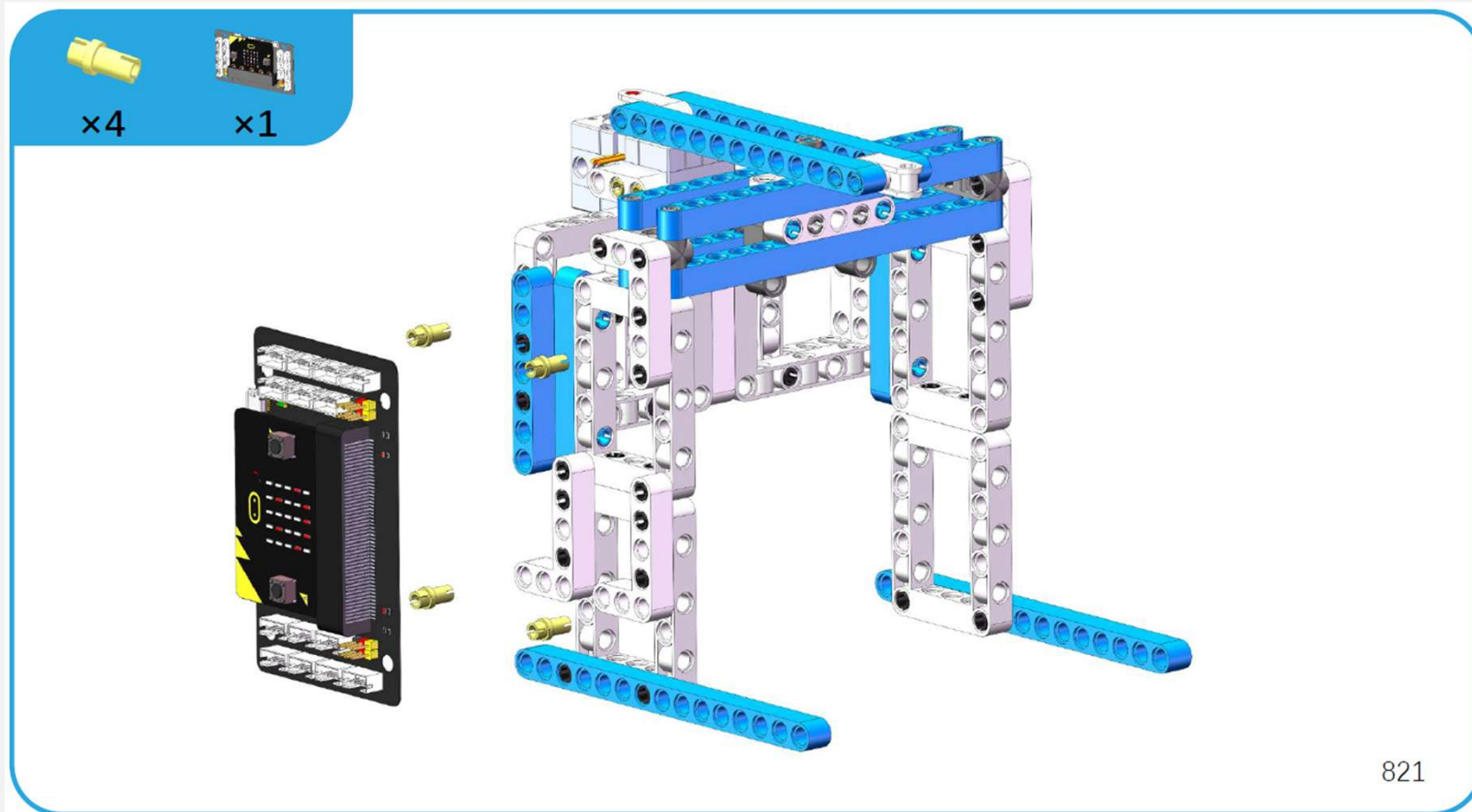

Step 69

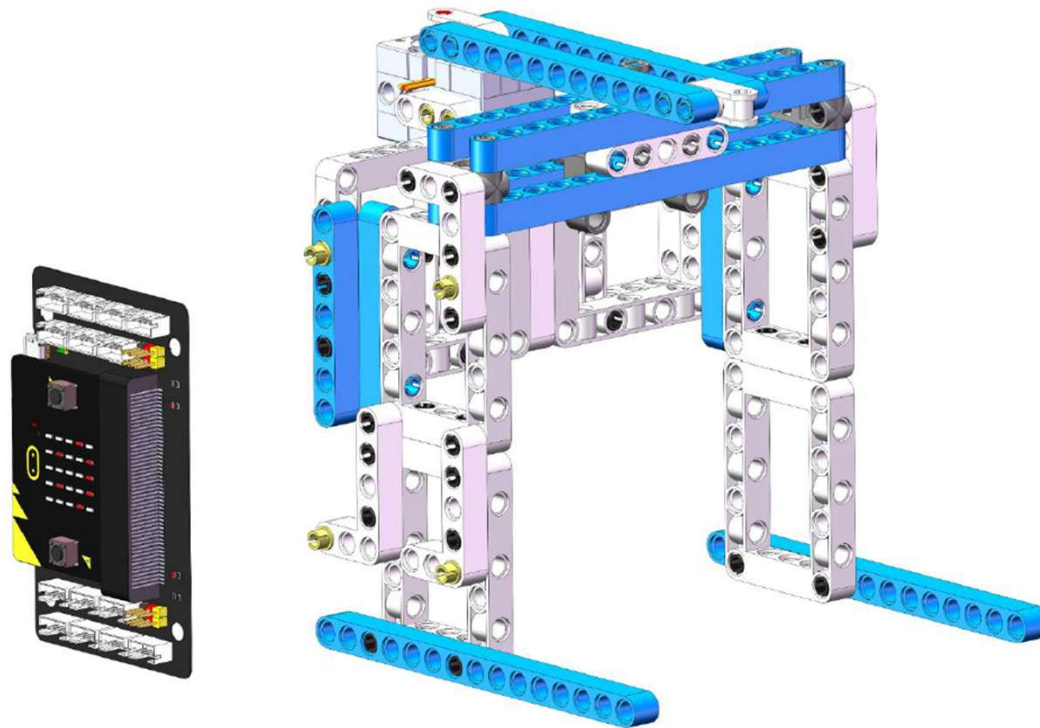

822

Step 70

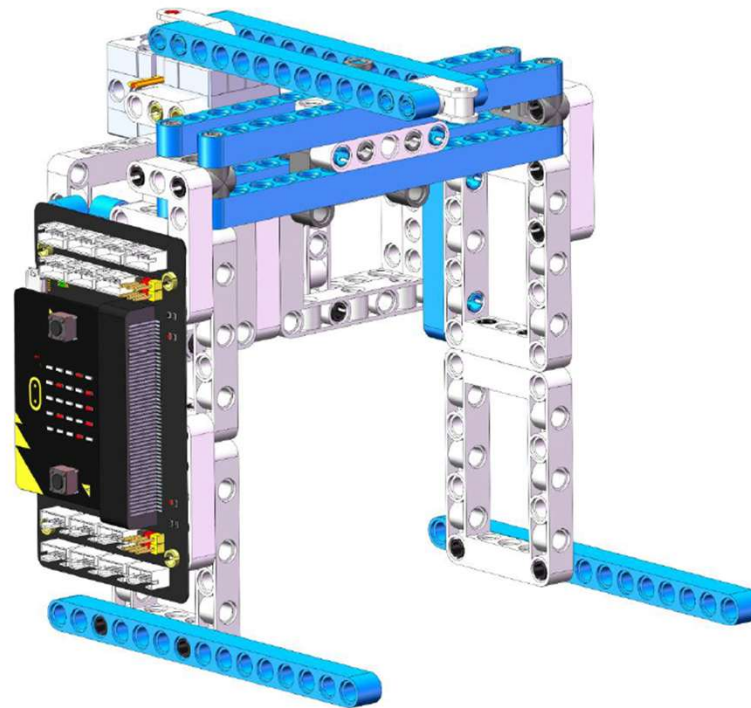

823

Step 71

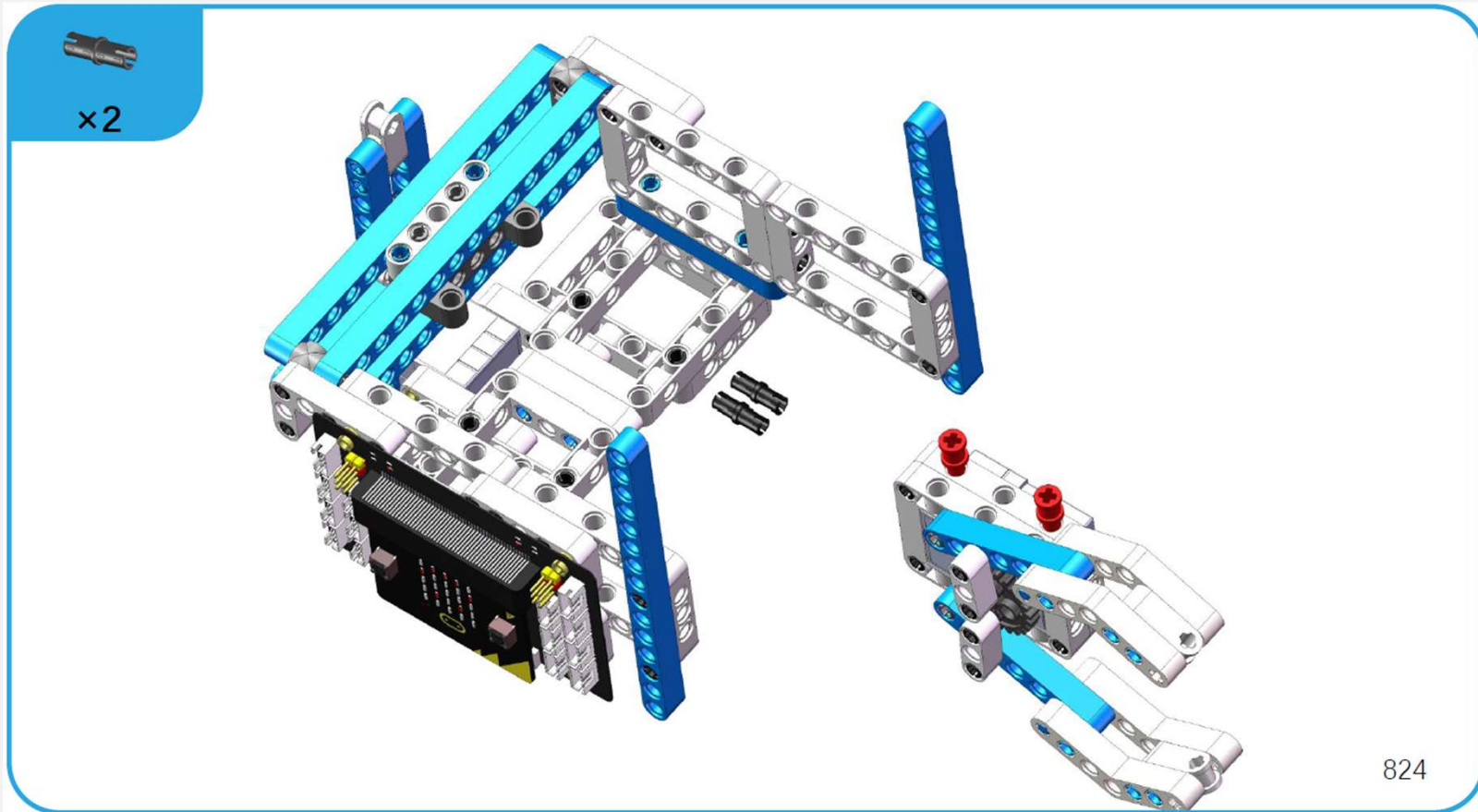

824

Step 72

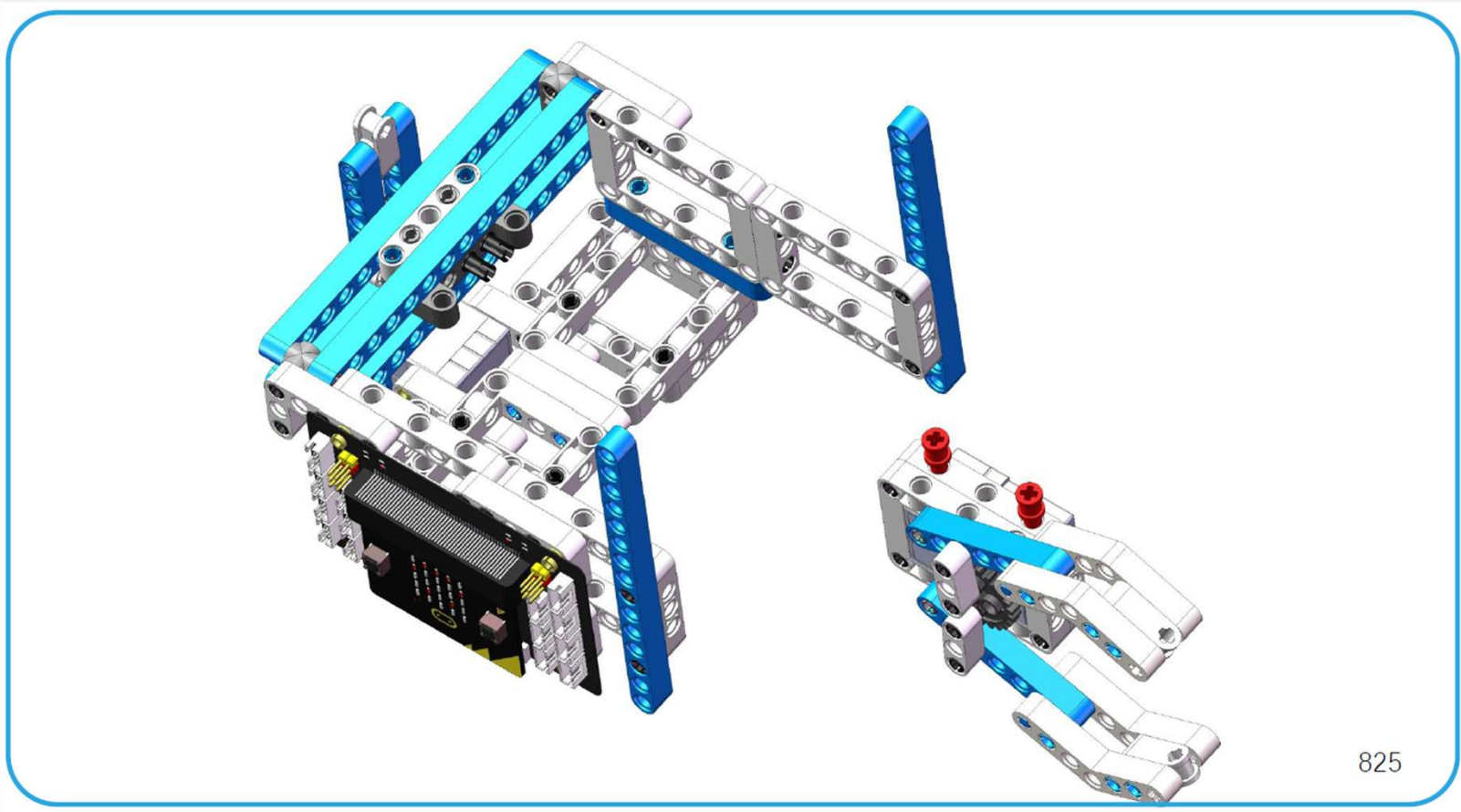

825

Step 73

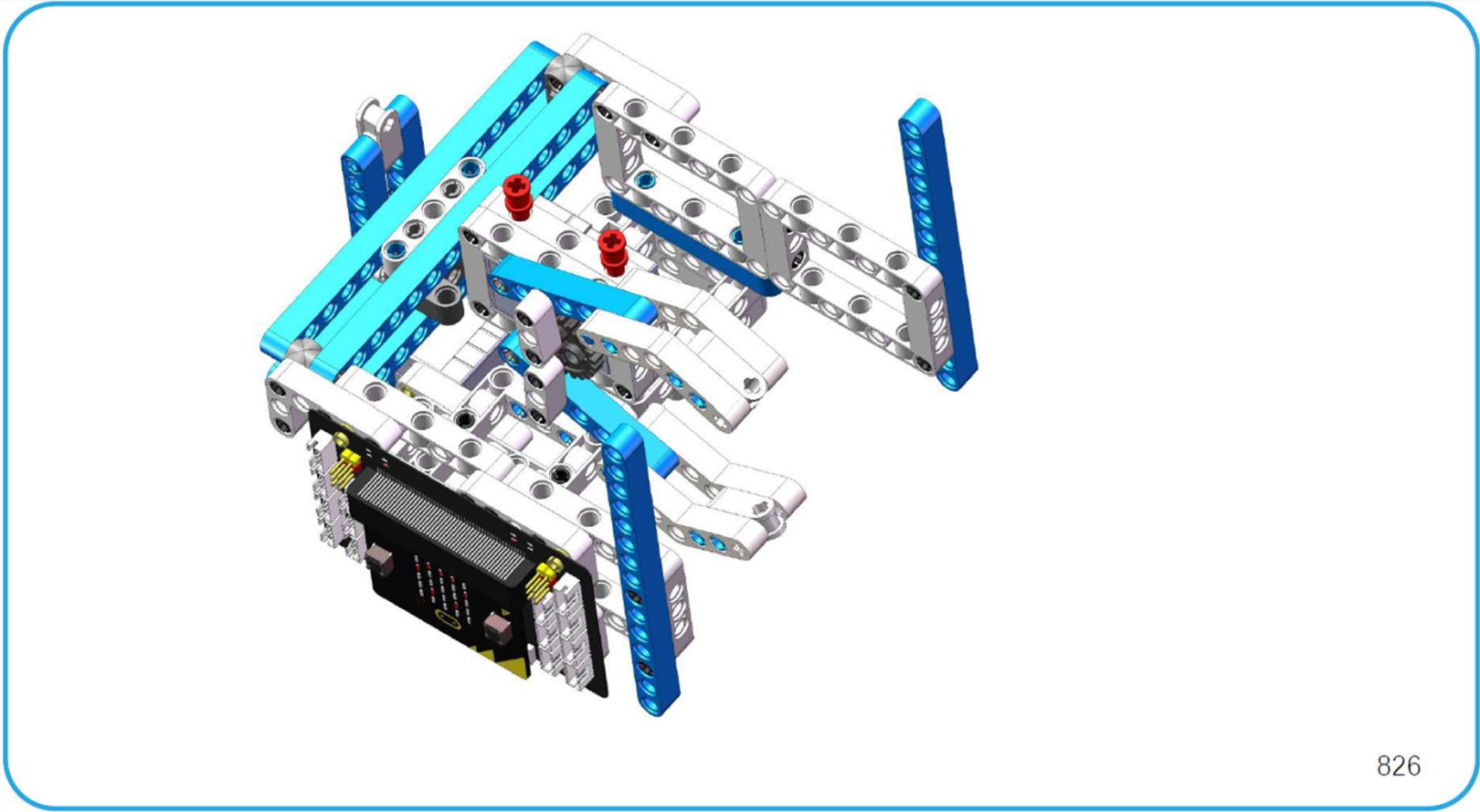

826

Step 74

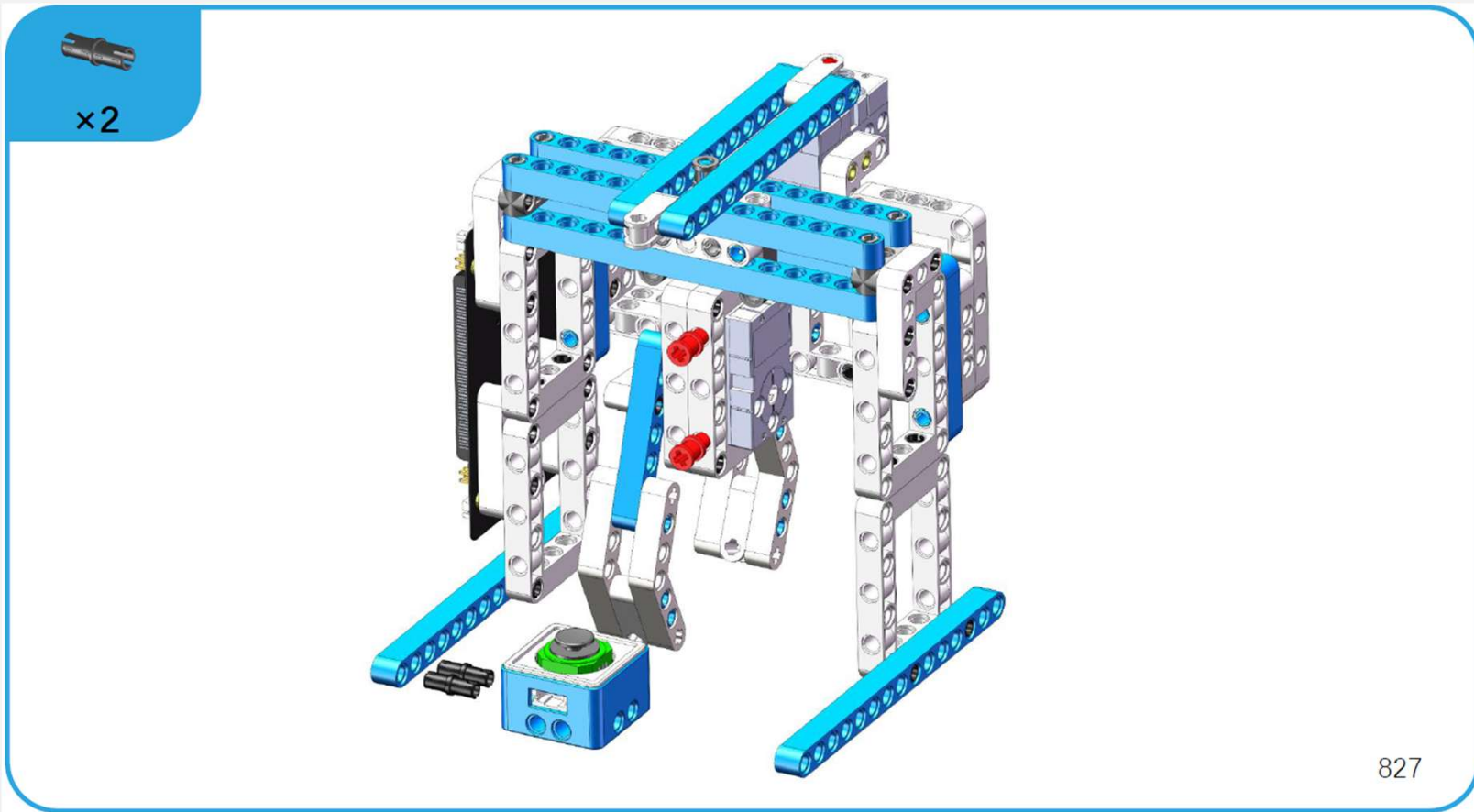

827

Step 75

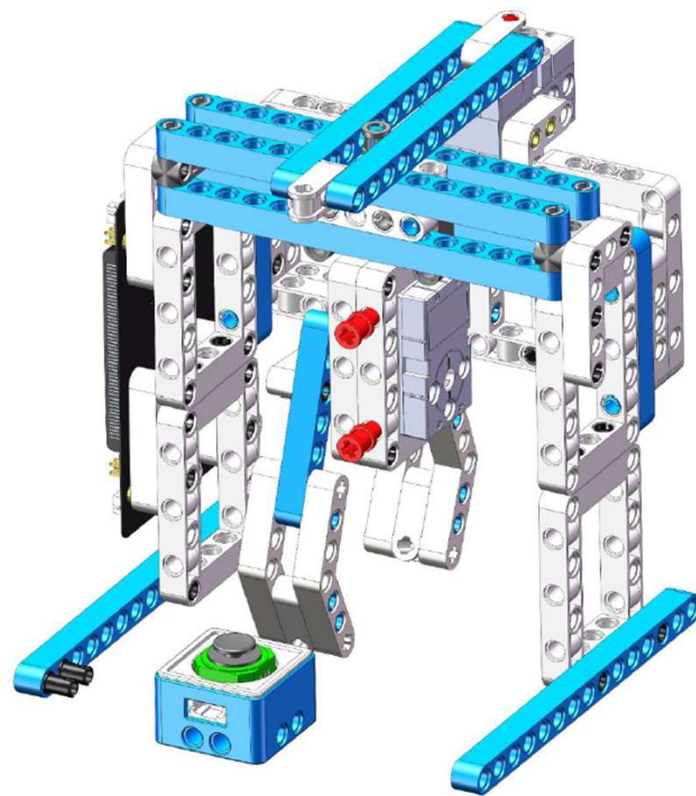

828

Step 76

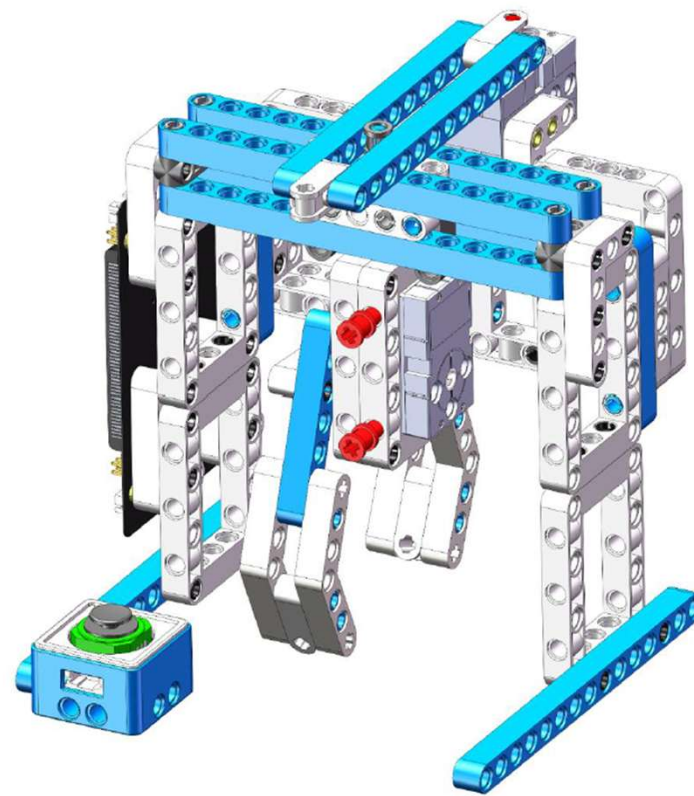

829

Please make sure that the wiper shaft is installed **correctly**, as shown below.

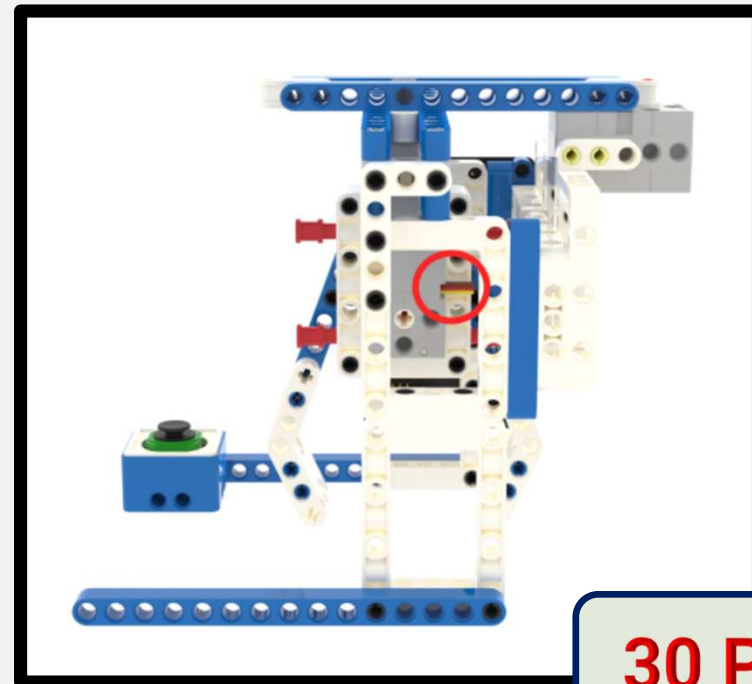
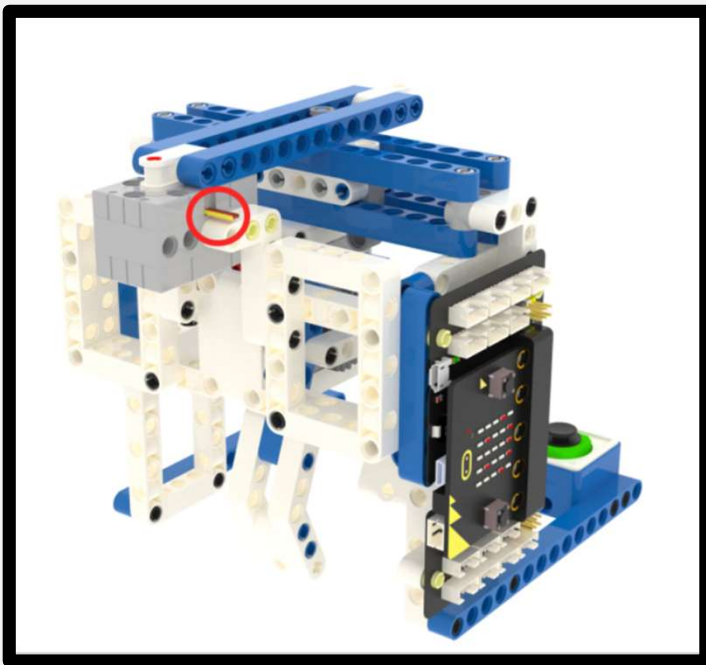

30 Points

Wire Connection

Connect the modules

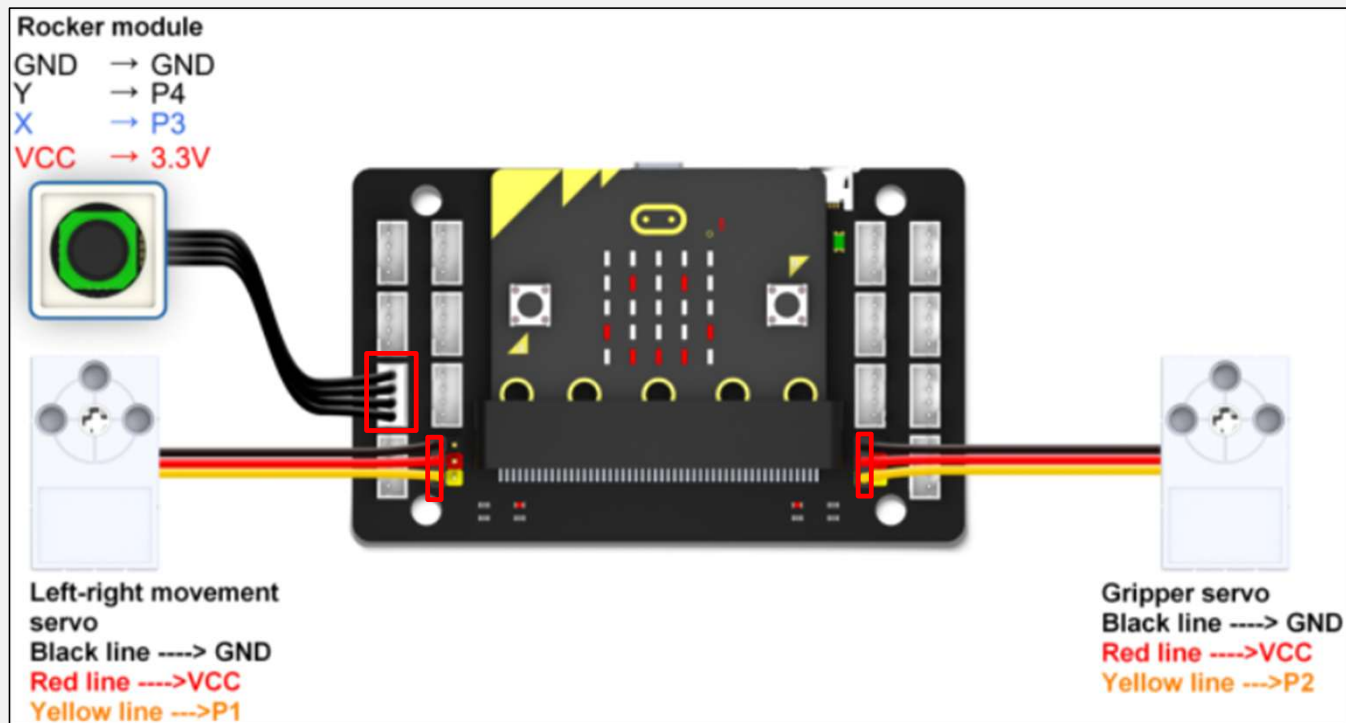

Let's **connect** the module like this.

Connect the modules

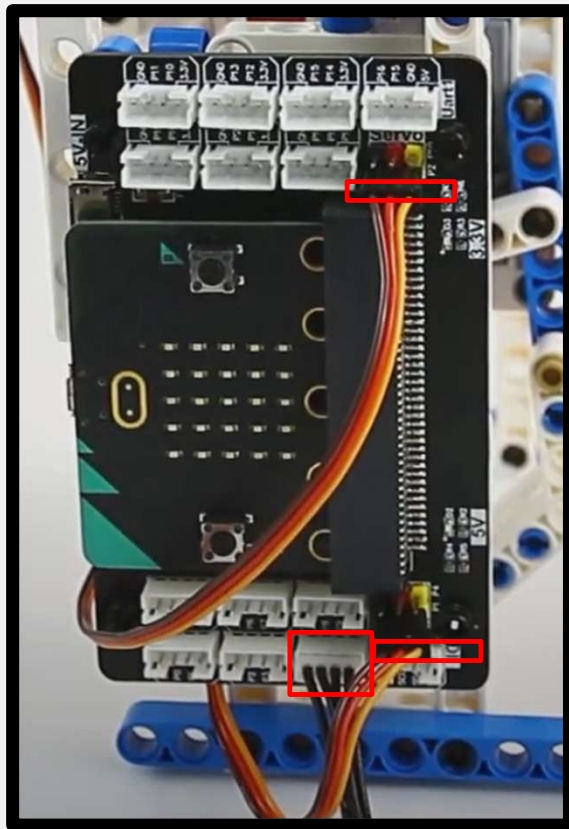

10 Points

Let's **connect** the module like this.

MakeCode Programming

<https://github.com/YahboomTechnology/Module-World>.

Or search [YahboomTechnology/Module-World](https://github.com/YahboomTechnology/Module-World) in the extension block

Coding – Variables

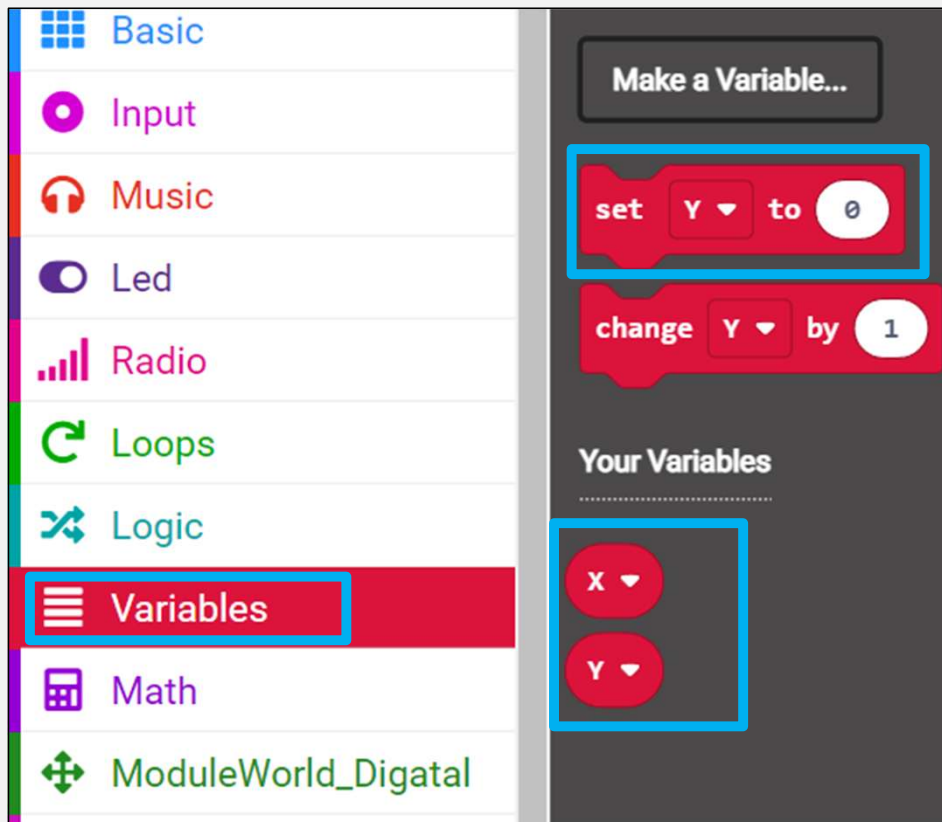

X Variable is to record the position of Left and Right.

Where Y Variable is to record the position of Up and Down (Gripper grip or release).

Coding – On start

```

on start
  led enable false
  set X to 180
  set Y to 140
  Servo(360) pin P1 value X
  Servo(360) pin P2 value Y
  
```

Link variables to the servo P1 and P2 for starting position.

And we will disable led on start so our voltage of other pins won't be affected.

Coding – forever

```
forever
  Servo(360) pin P1 value X
  Servo(360) pin P2 value Y
  if Rocker pin P3P4 value Up then
    change Y by 1
  else if Rocker pin P3P4 value Down then
    change Y by -1
  else if Rocker pin P3P4 value Left then
    change X by 1
  else if Rocker pin P3P4 value Right then
    change X by -1
```

Add in rocker control

Coding – forever



```
forever
  if X < 150 then
    set X to 150
  else if X > 207 then
    set X to 207
  else if Y < 70 then
    set Y to 70
  else if Y > 140 then
    set Y to 140
```

To ensure the safety of the servo and overturn is not allowed, we will set minimum and maximum for both X and Y to protect the servos.

Coding - Overview



```
on start
  led enable false
  set X to 180
  set Y to 140
  Servo(360) pin P1 value X
  Servo(360) pin P2 value Y
```

```
forever
  Servo(360) pin P1 value X
  Servo(360) pin P2 value Y
  if Rocker pin P3P4 value Up then
    change Y by 1
  else if Rocker pin P3P4 value Down then
    change Y by -1
  else if Rocker pin P3P4 value Left then
    change X by 1
  else if Rocker pin P3P4 value Right then
    change X by -1
```

```
forever
  if X < 150 then
    set X to 150
  else if X > 207 then
    set X to 207
  else if Y < 70 then
    set Y to 70
  else if Y > 140 then
    set Y to 140
```

Phenomenon

After the program is downloaded successfully. We **control** UFO catcher **movement** and **Gripping-release** by rocker module.

30 Points

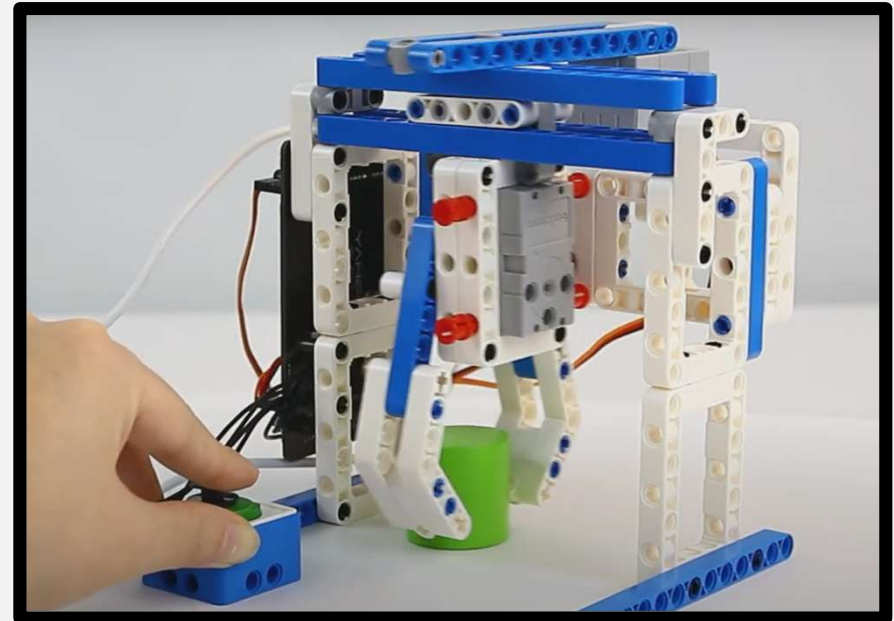
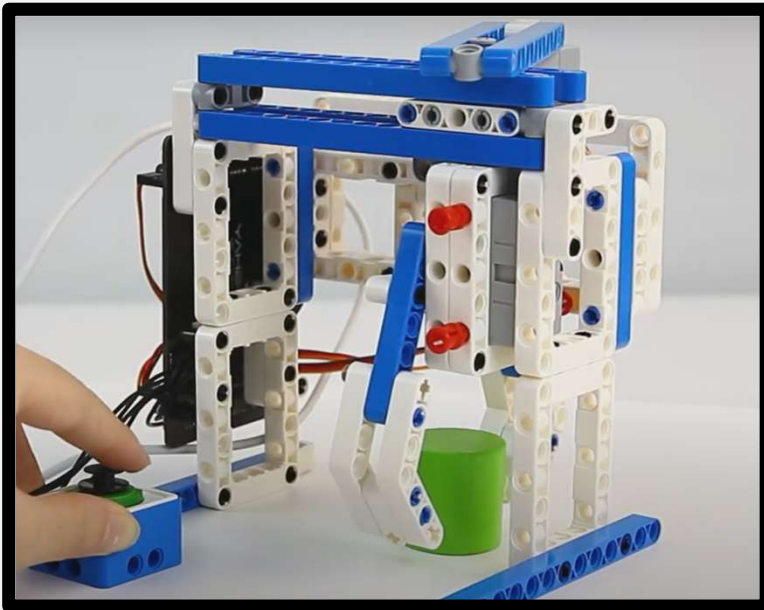

CHALLENGE

for : Lesson 5



L5 – Challenge 1

Explain about how your UFO Catcher work.

Can you give an example of how this can be applied in real-life?

Briefly explain about how the coding works.

30 Points

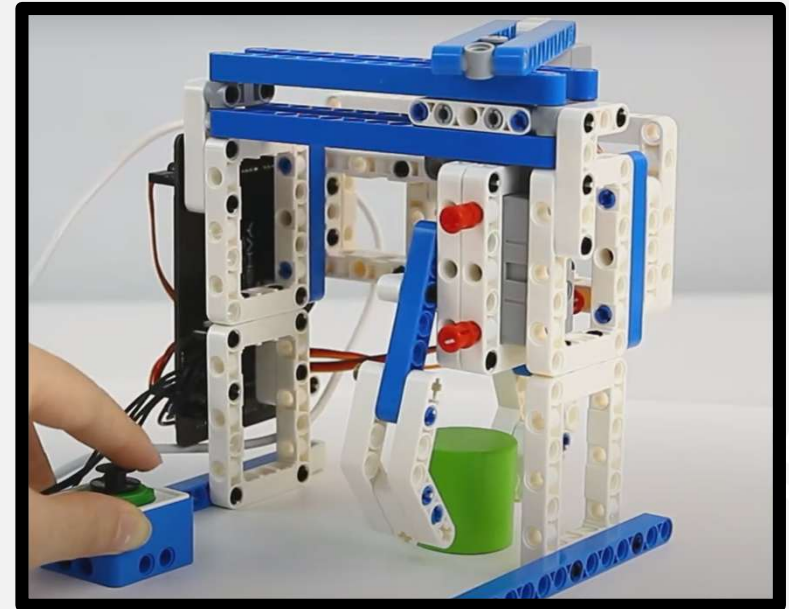

L5 – Challenge 2

After the program is downloaded successfully.

Add **button** module.

Use the button to control the **Gripping-release**

Example:

When the button is pressed, the UFO catcher will **grip**

When the button is pressed again, it will **release** the grip

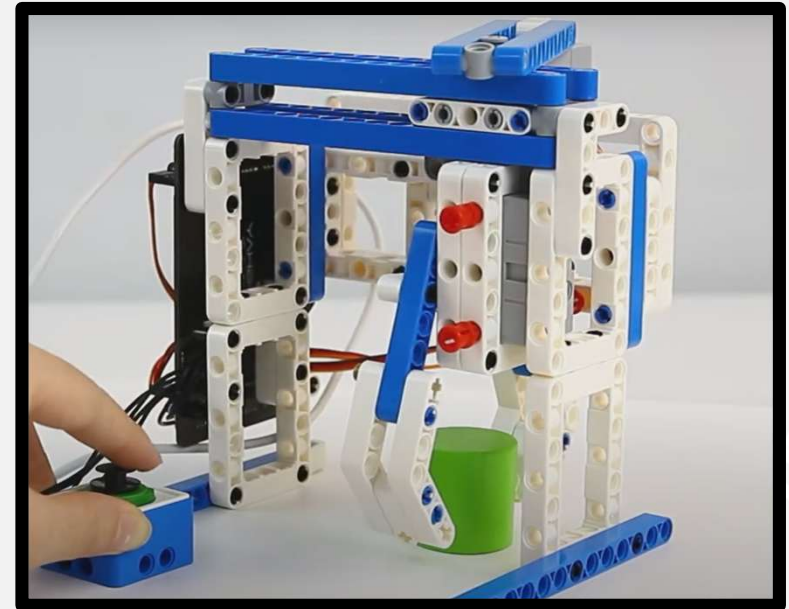

30 Points

L5 – Challenge 3

After the program is downloaded successfully.

Use the button module to **control** UFO catcher **movement** and **Gripping-release**.

Example:

When the button is pressed, the UFO catcher will **move** to the **right**, and then **grip**.

When the button is pressed again, the UFO catcher will **move** to the **left**, and it will **release** the grip

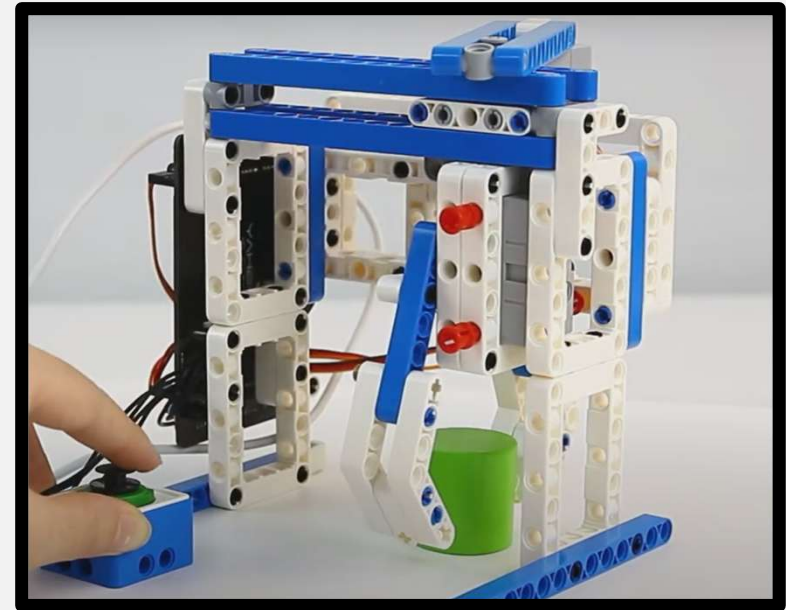

30 Points