

Microbit Robotics Advanced Level 3

Lesson 3

Clip Robot

Presented by Advanced Superlogic Team

Today's Topic

1. **Build your Robot Base**
2. **Build the clipper for your Robot**
3. **Clip Robot Programming**
4. **Robot Mini Game**

Learning Outcome

- 1. Able to build a robot base for your clip robot**
- 2. Able to build a clipper for your robot**
- 3. Understand how to program your clip robot with remote controller function**

Build your Robot Base



Step 1

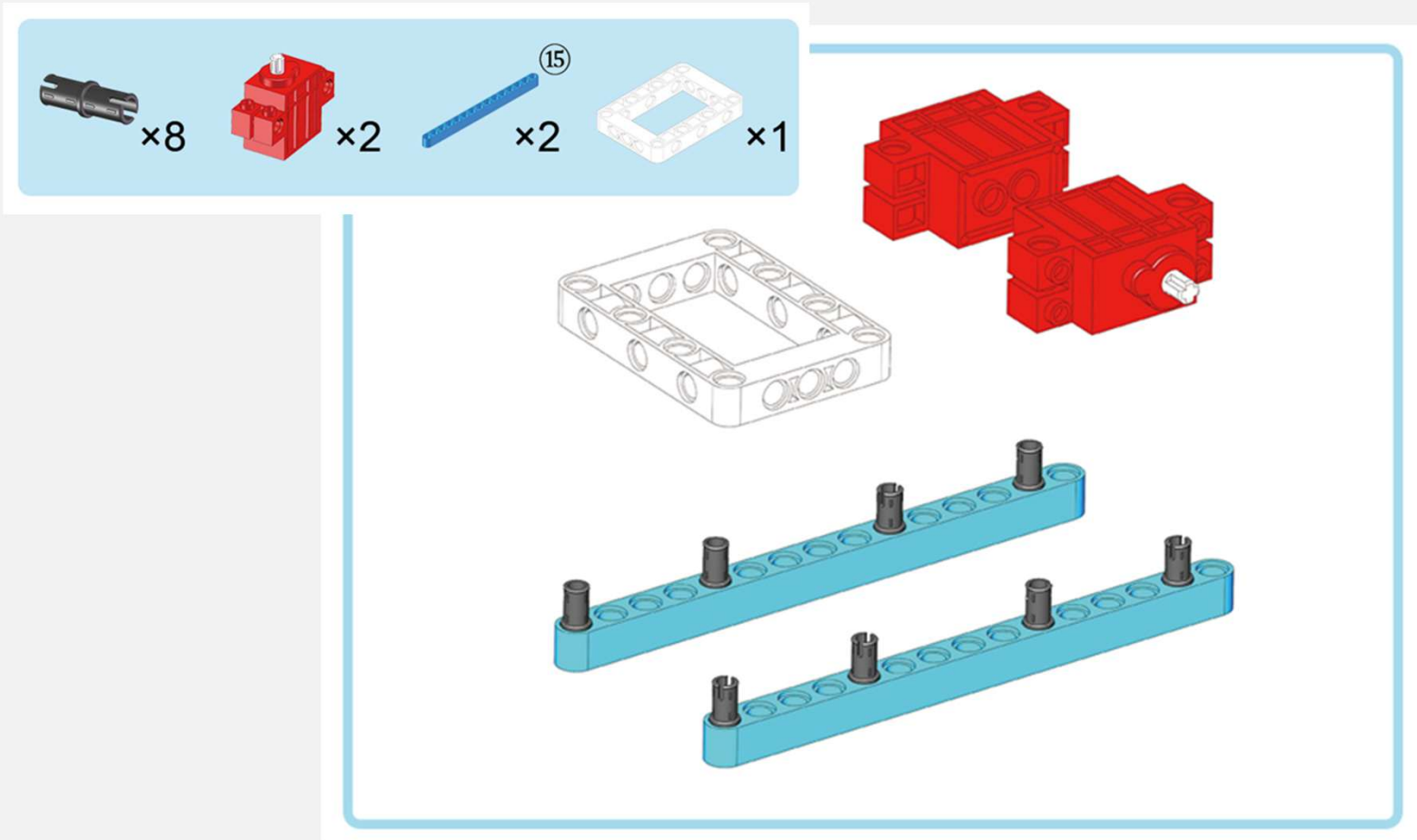

Step 2

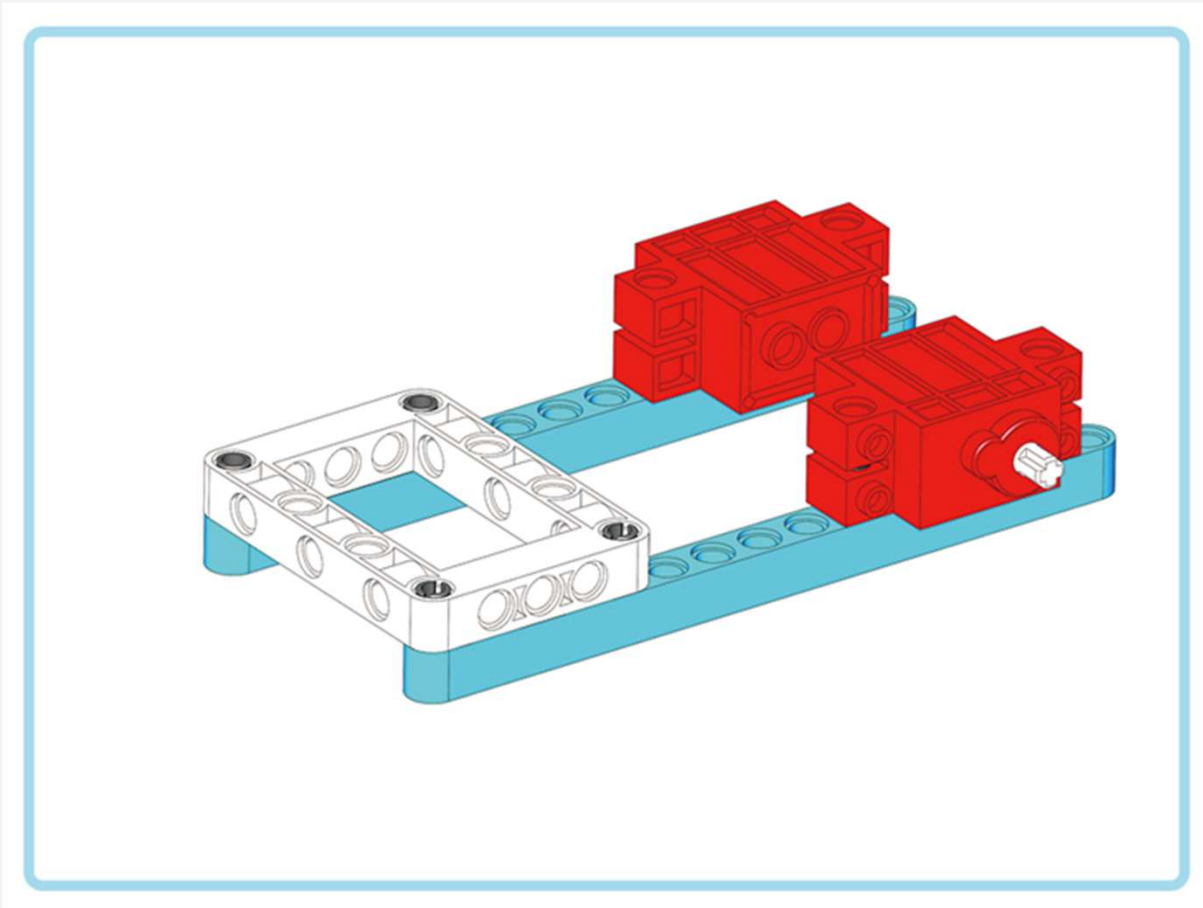

Step 3

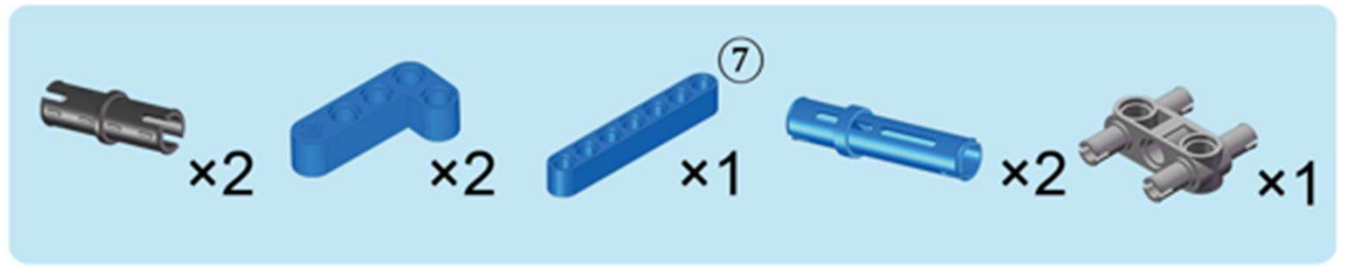
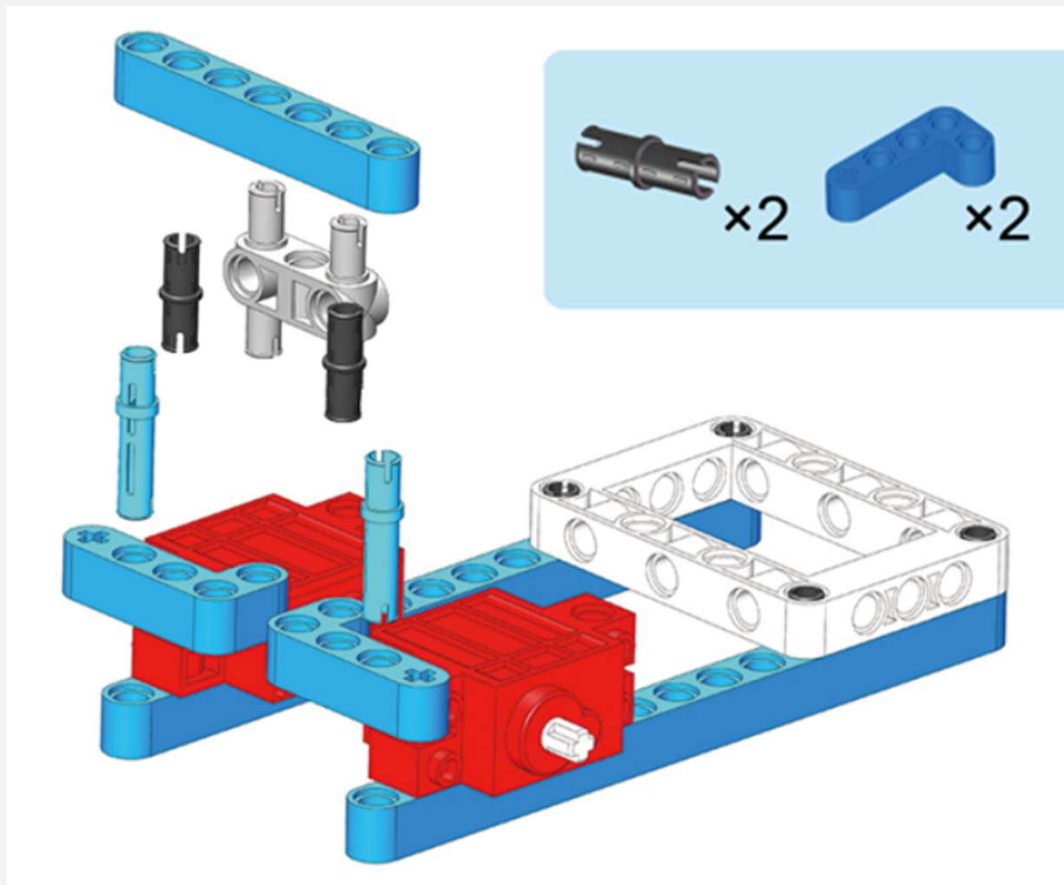

Step 4

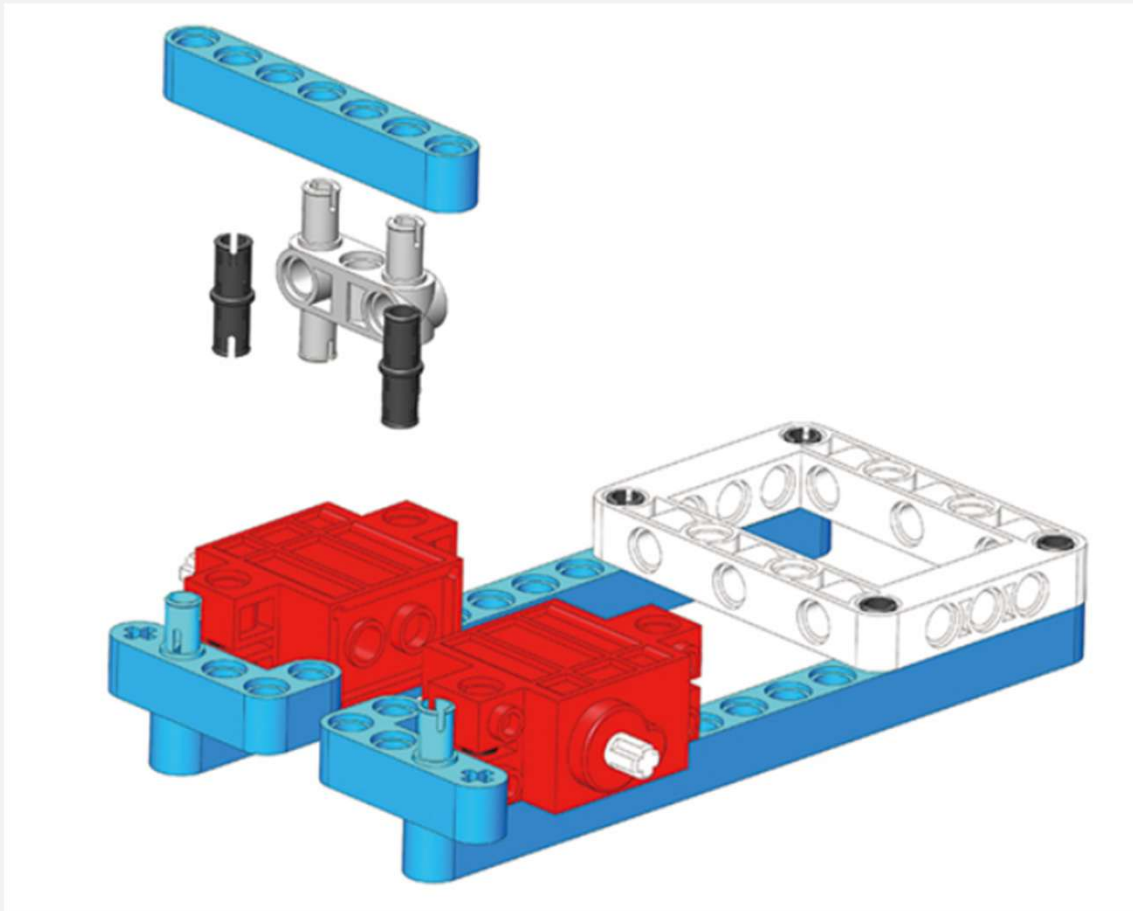

Step 5

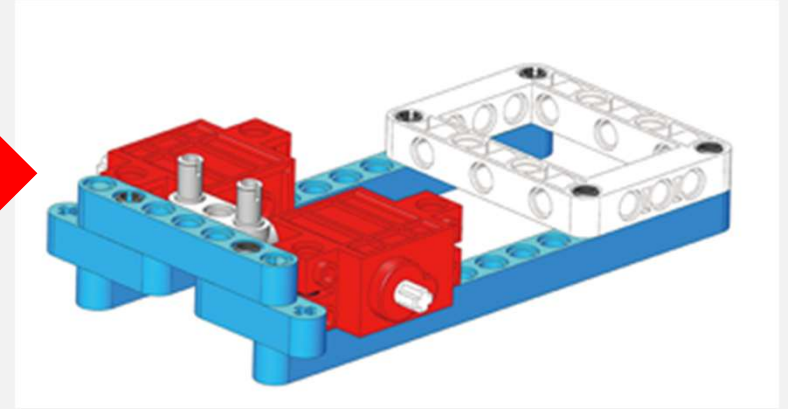
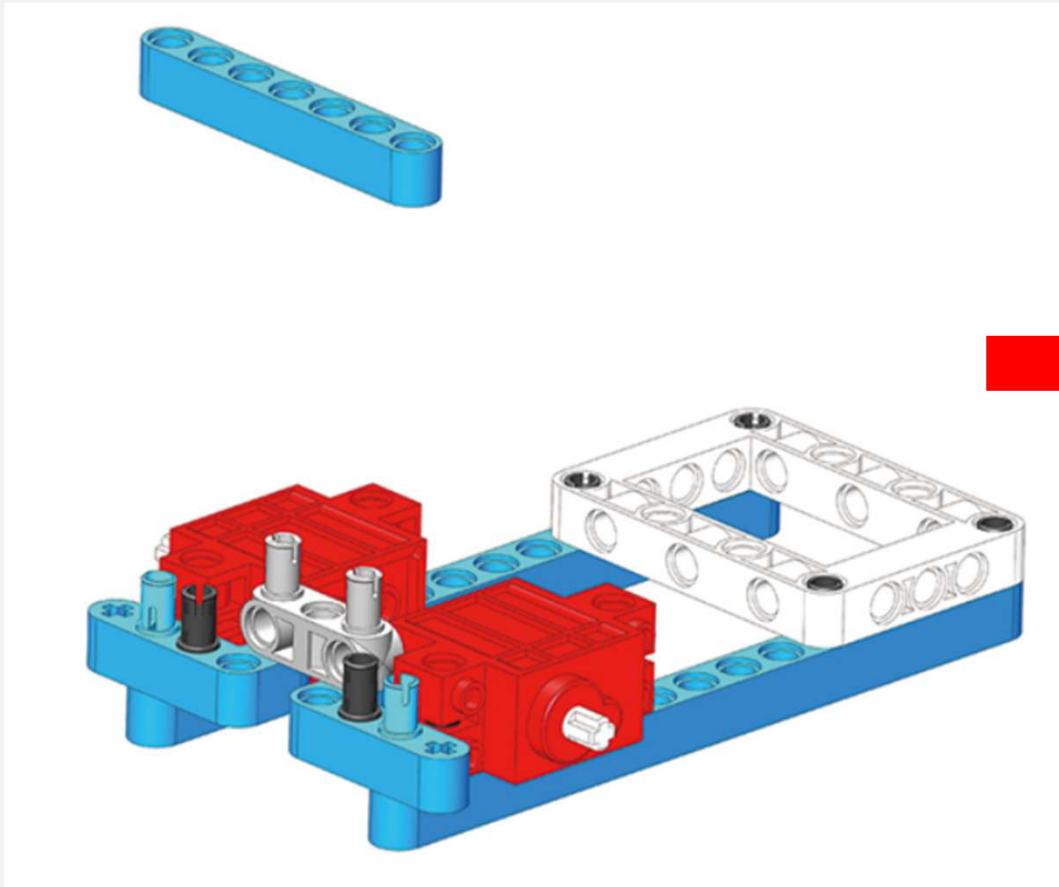

Step 6

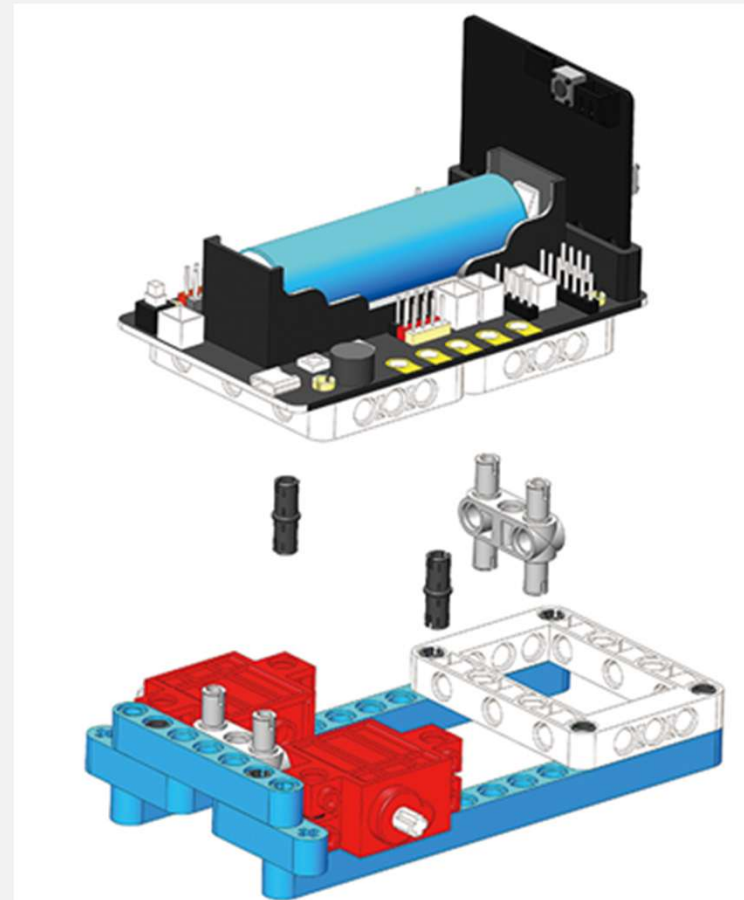
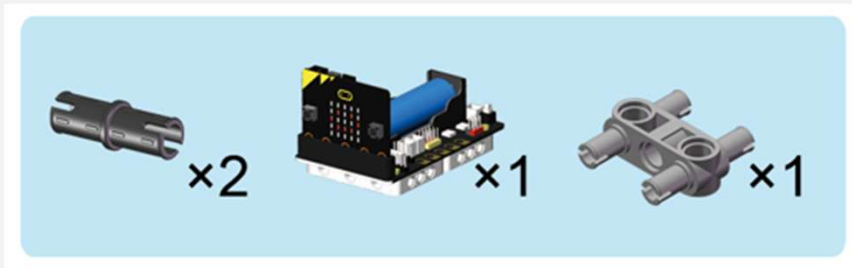

Step 7

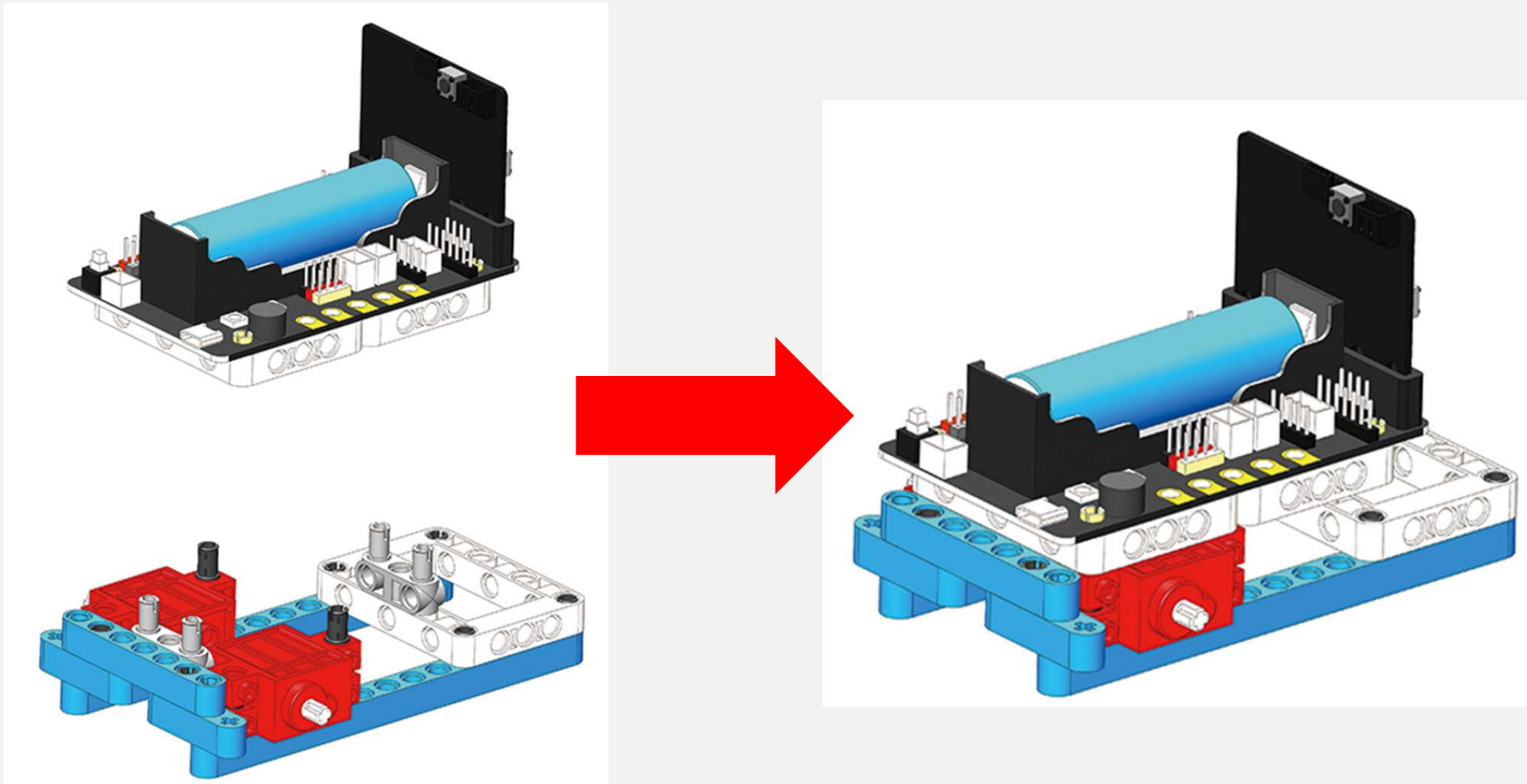



Step 8

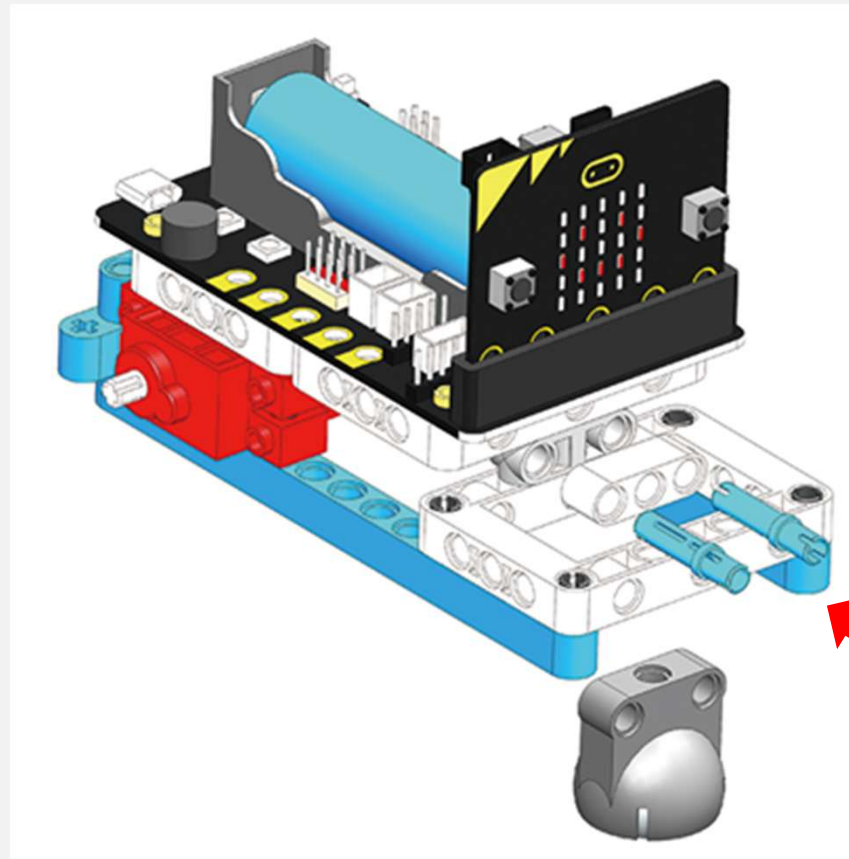
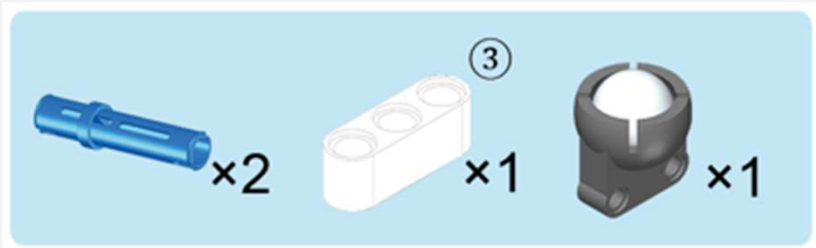

Step 9

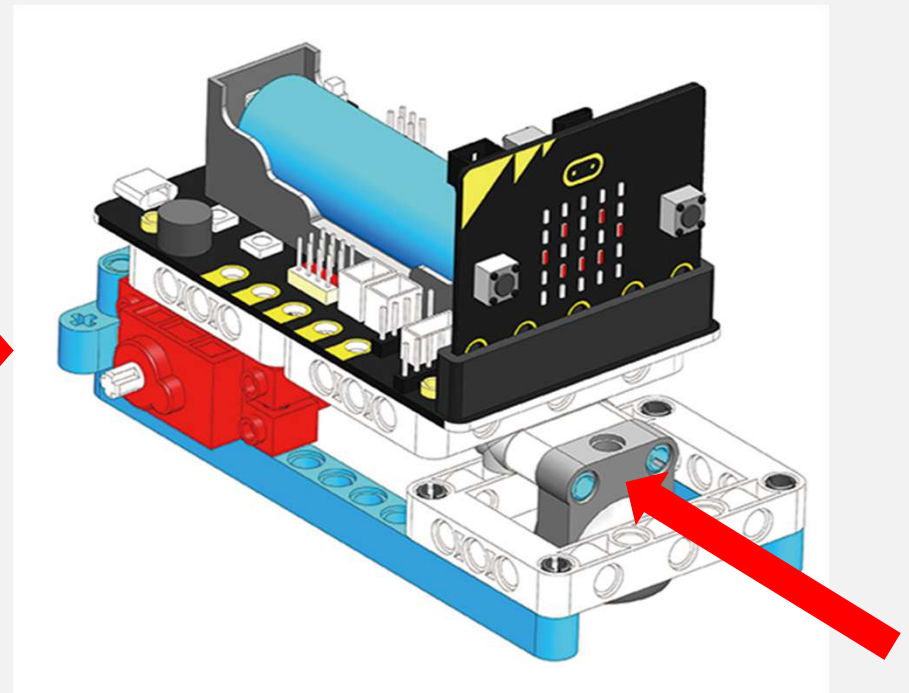
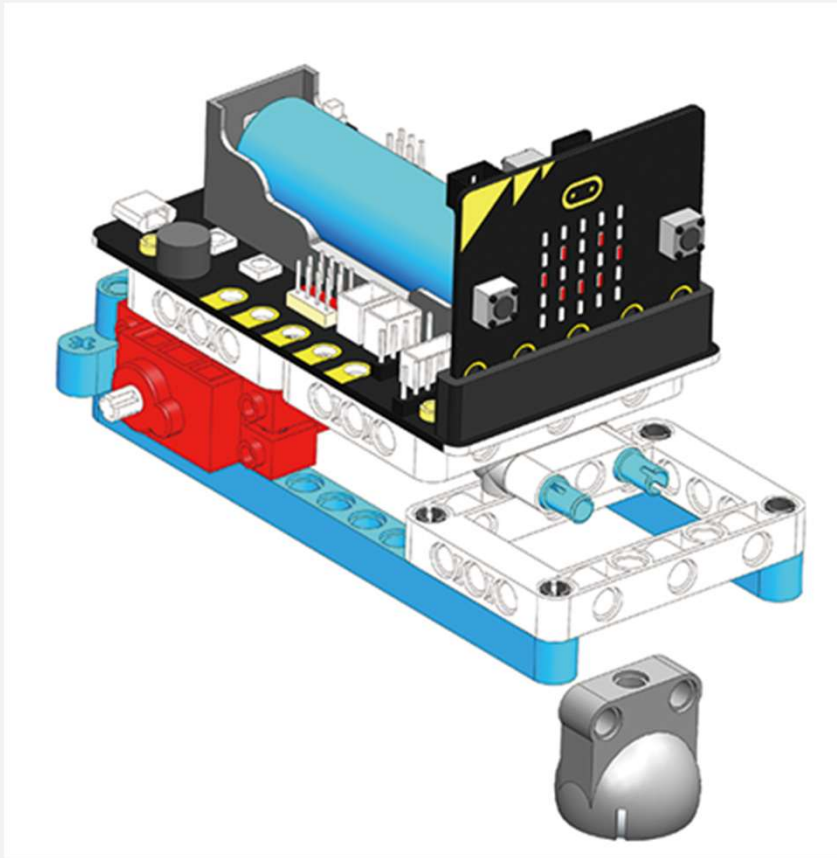

Step 10

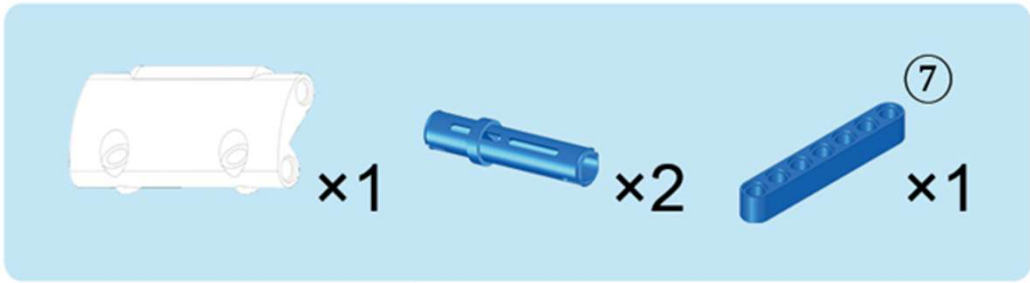
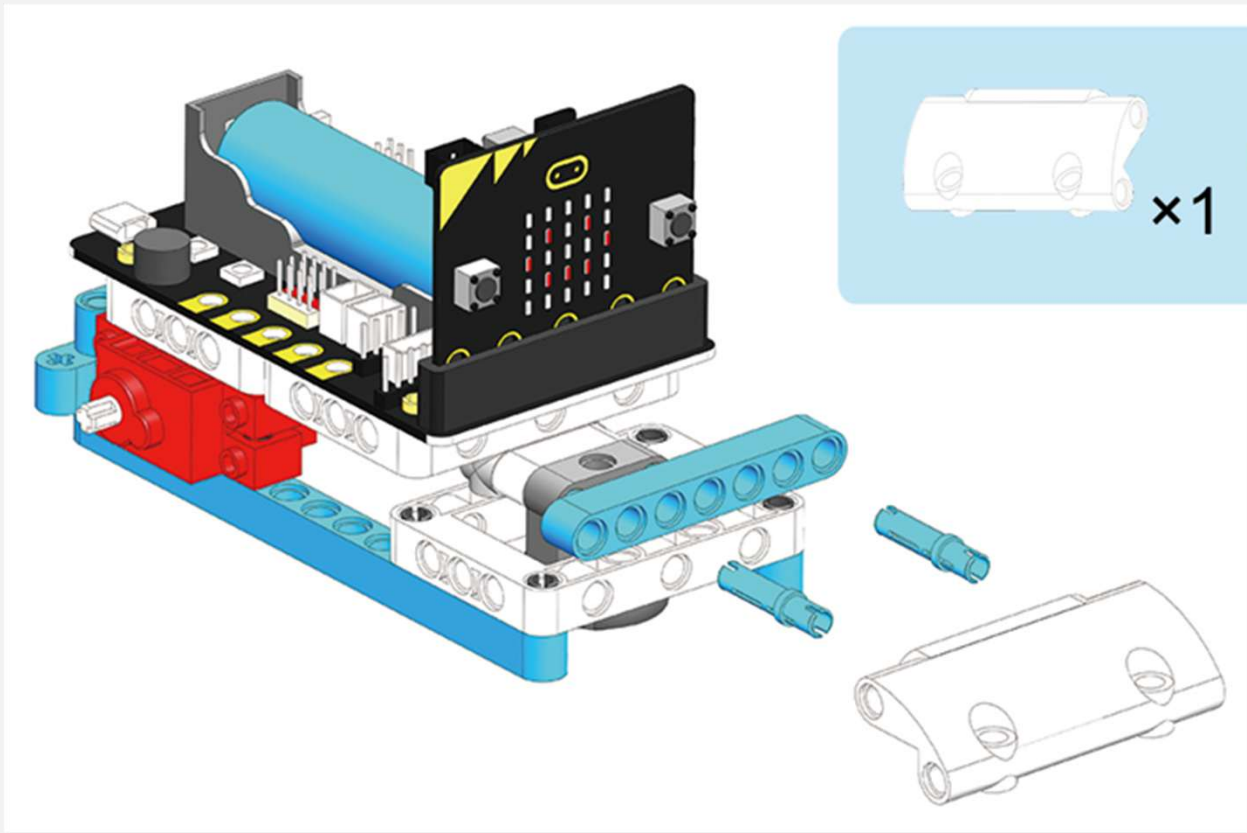

Step 11

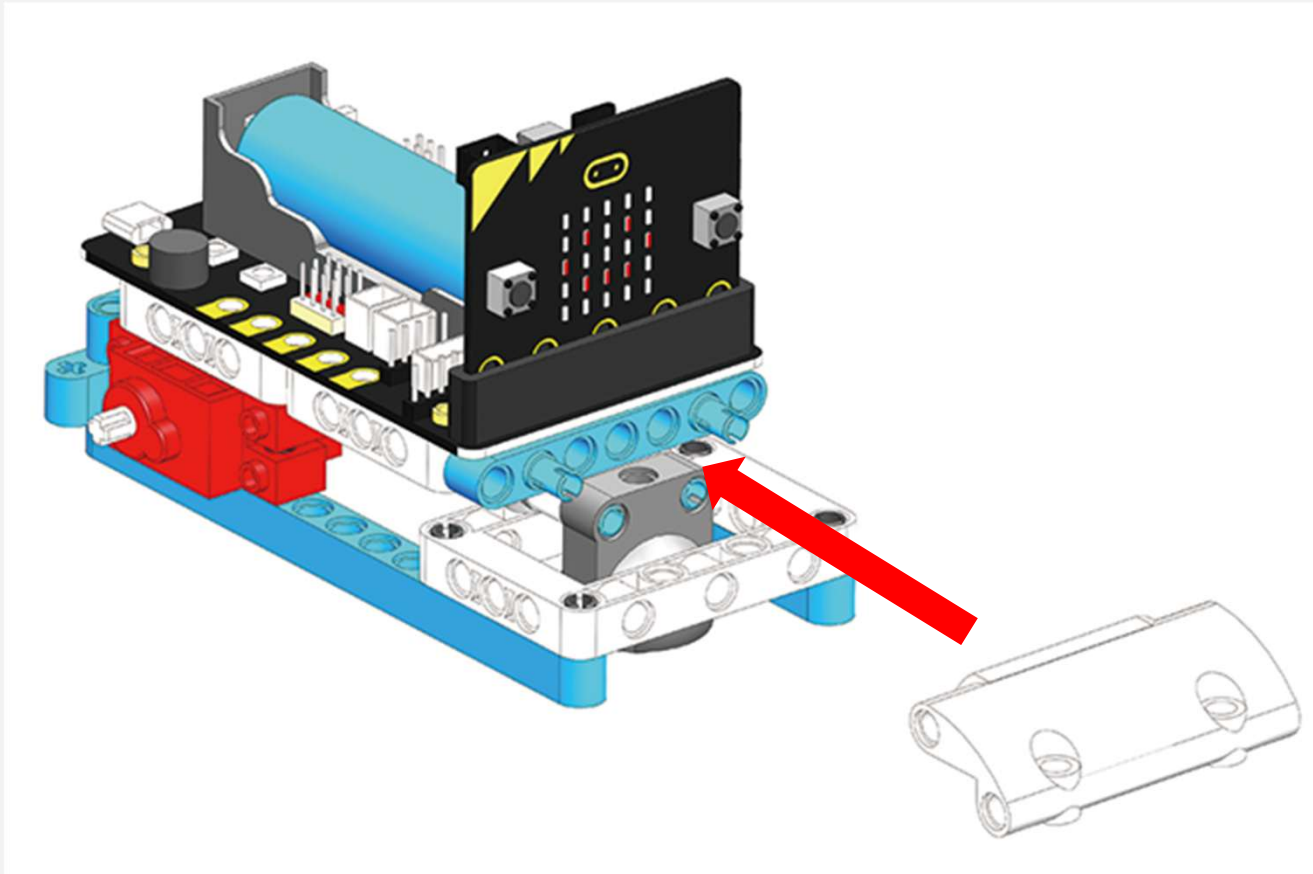

Step 12

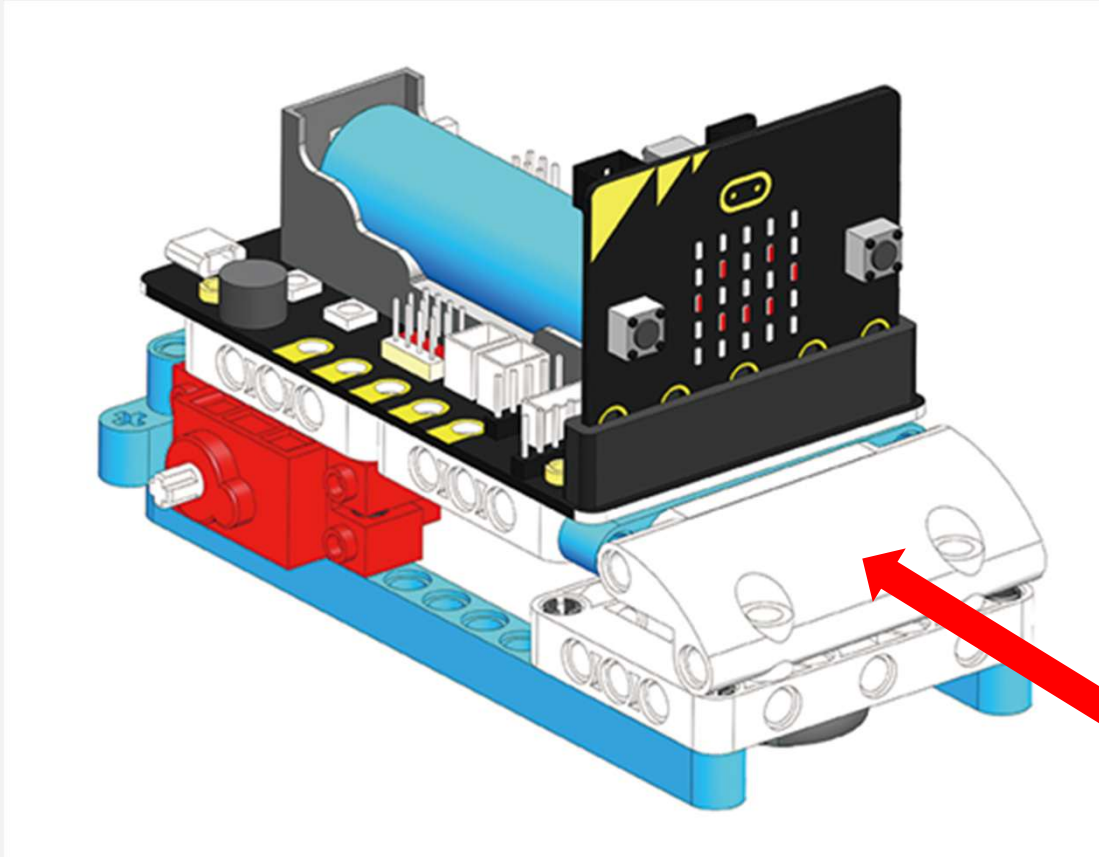

Step 13

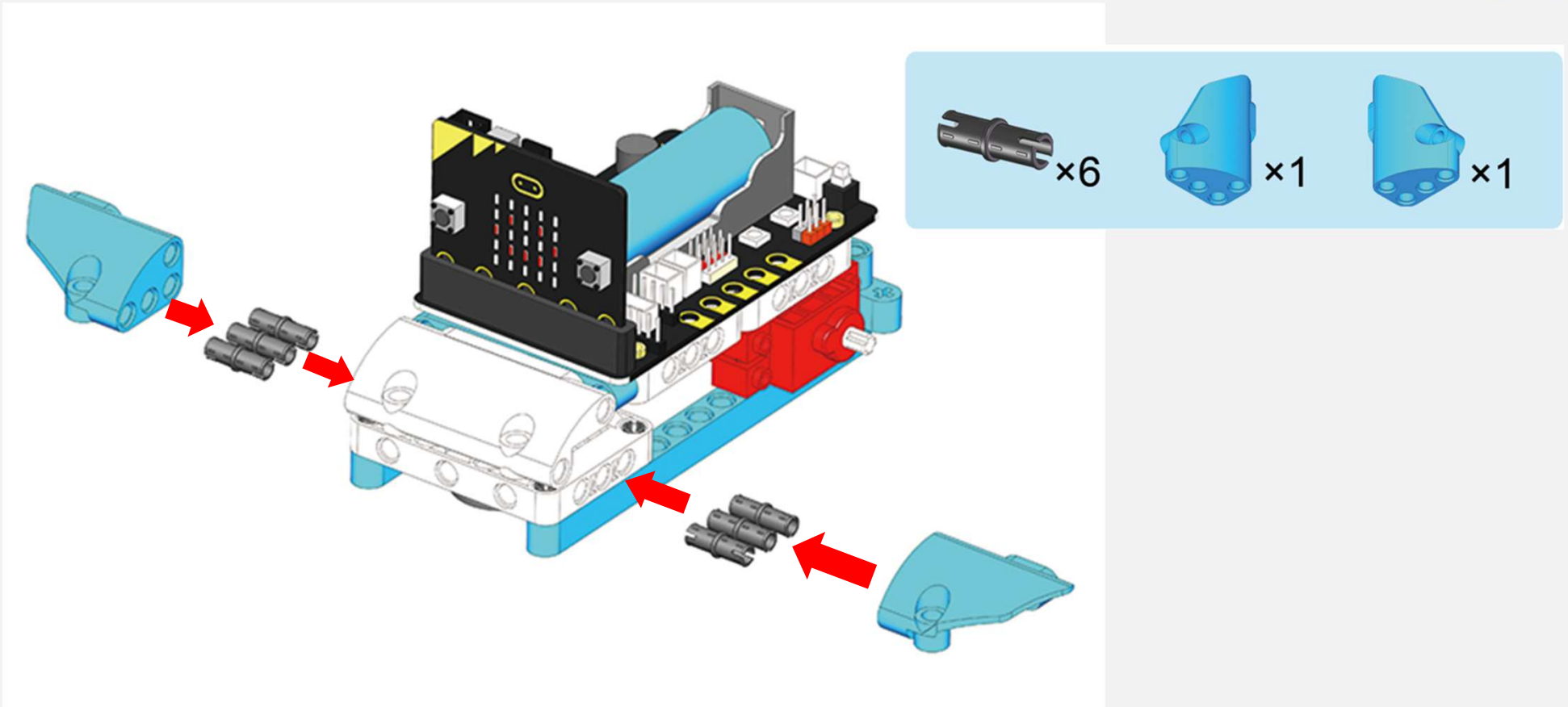

Step 14

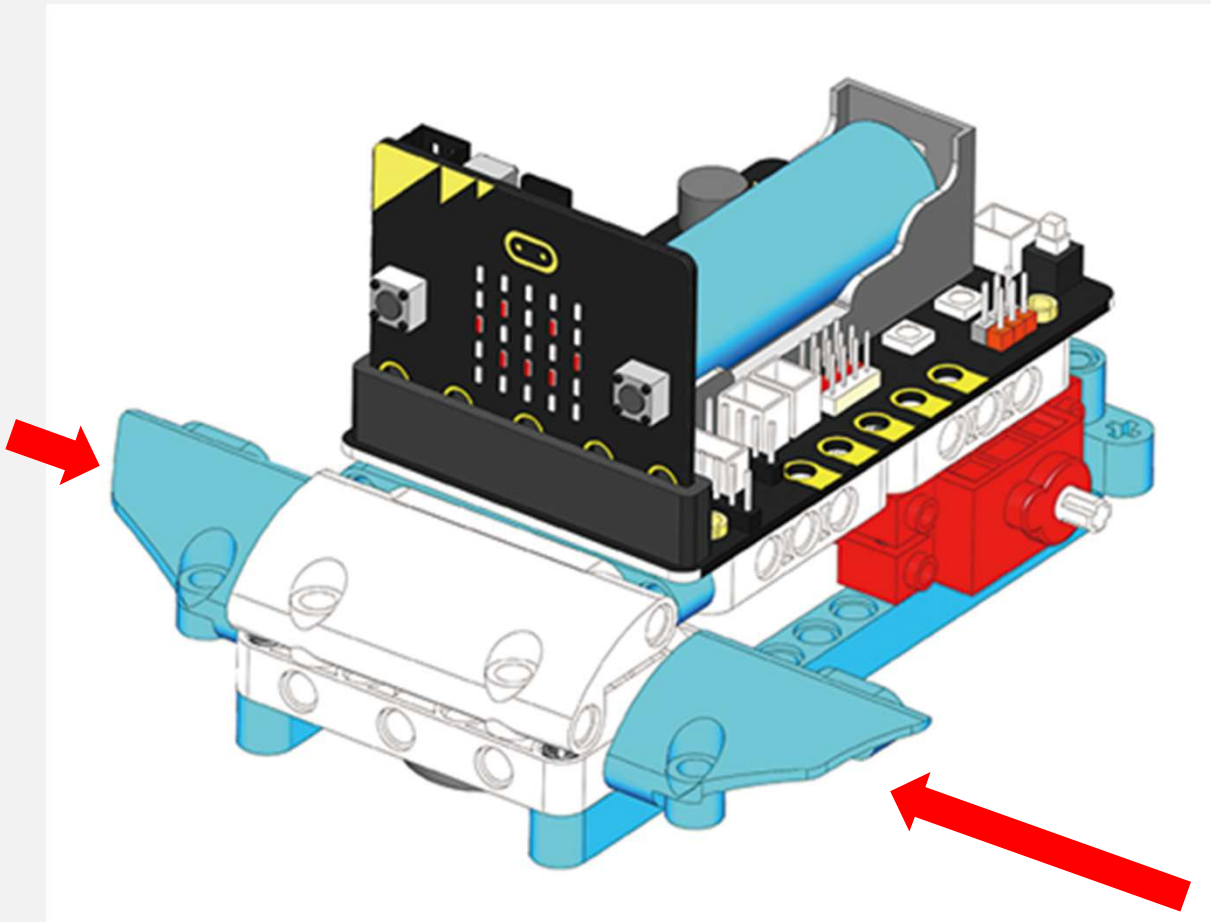

Step 15

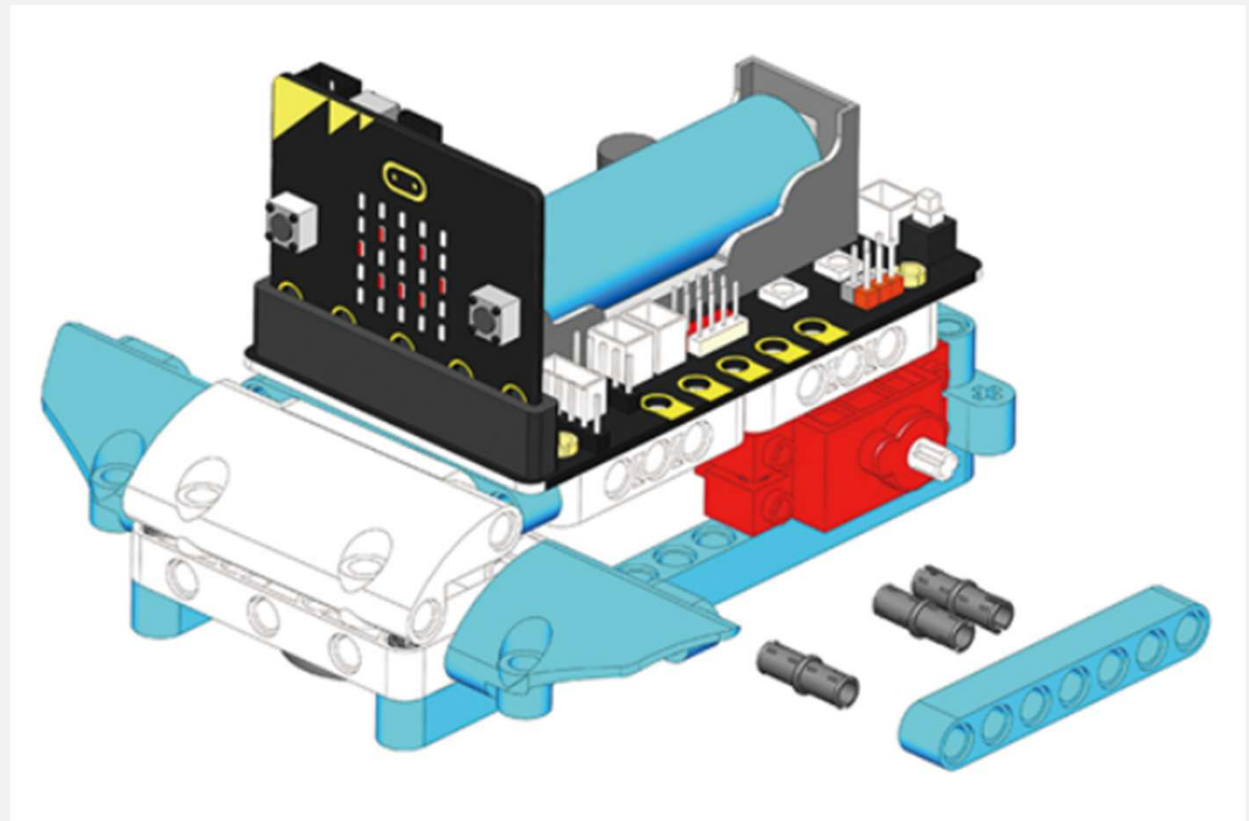
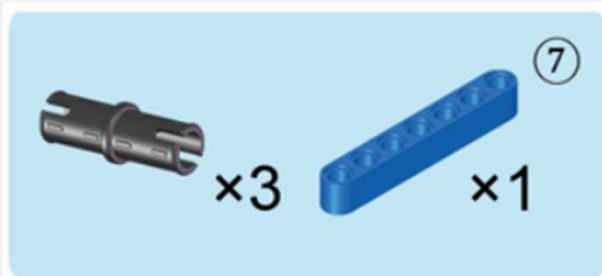

Step 16

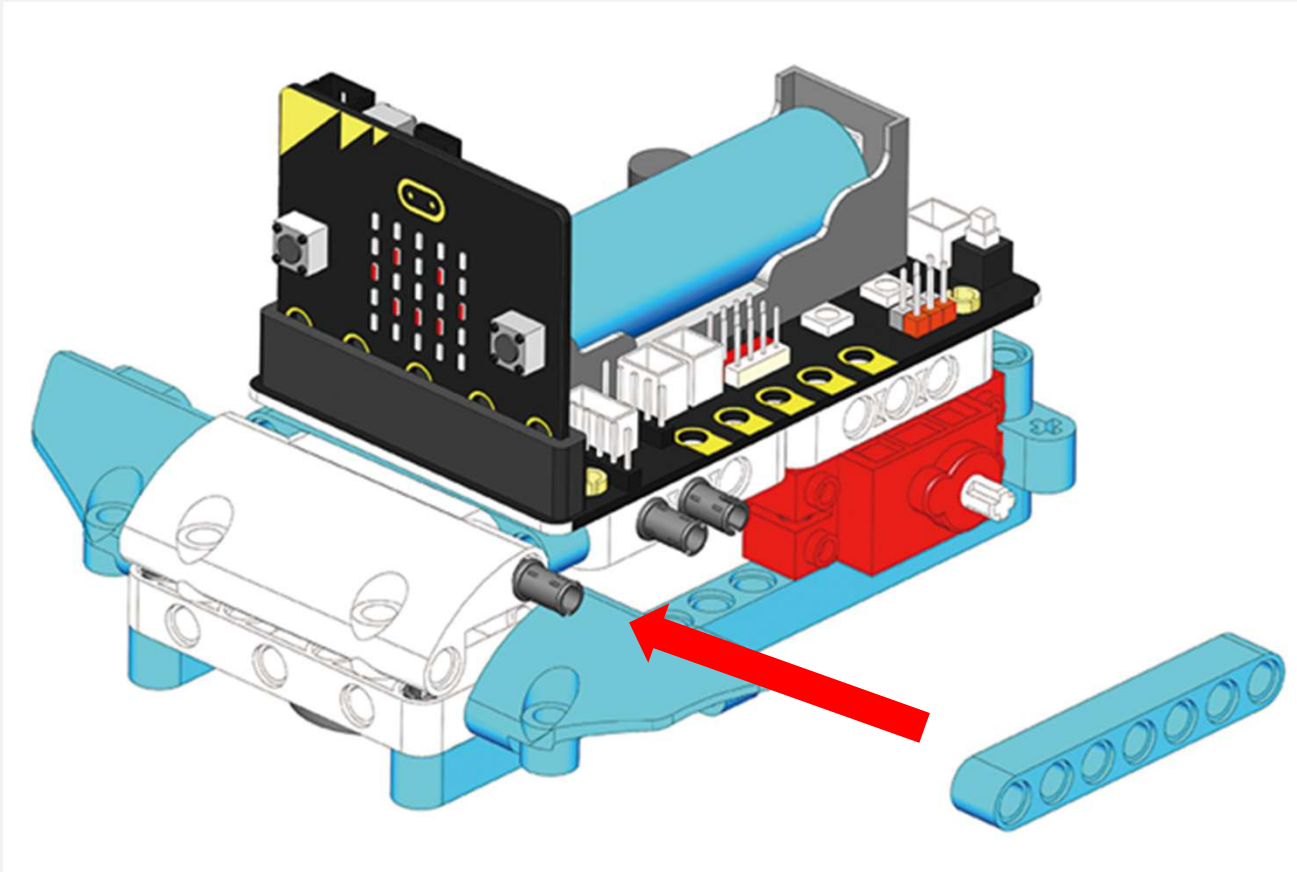

Step 17

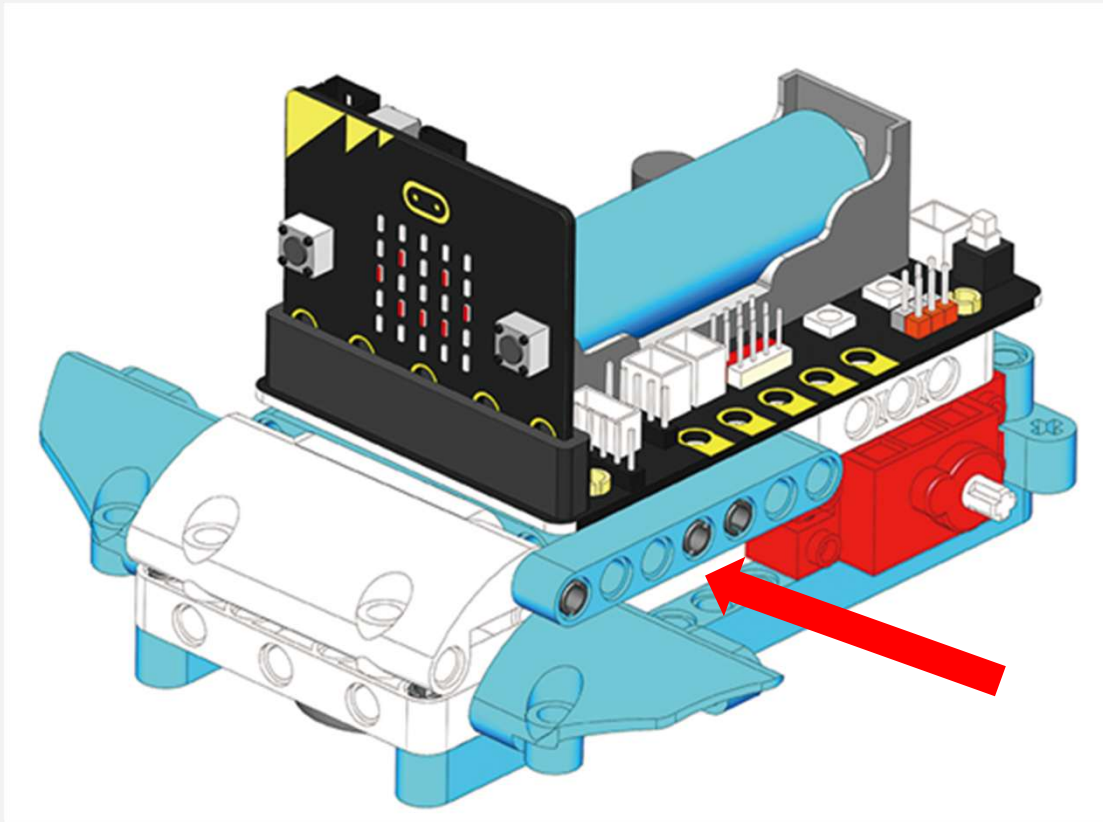

Step 18

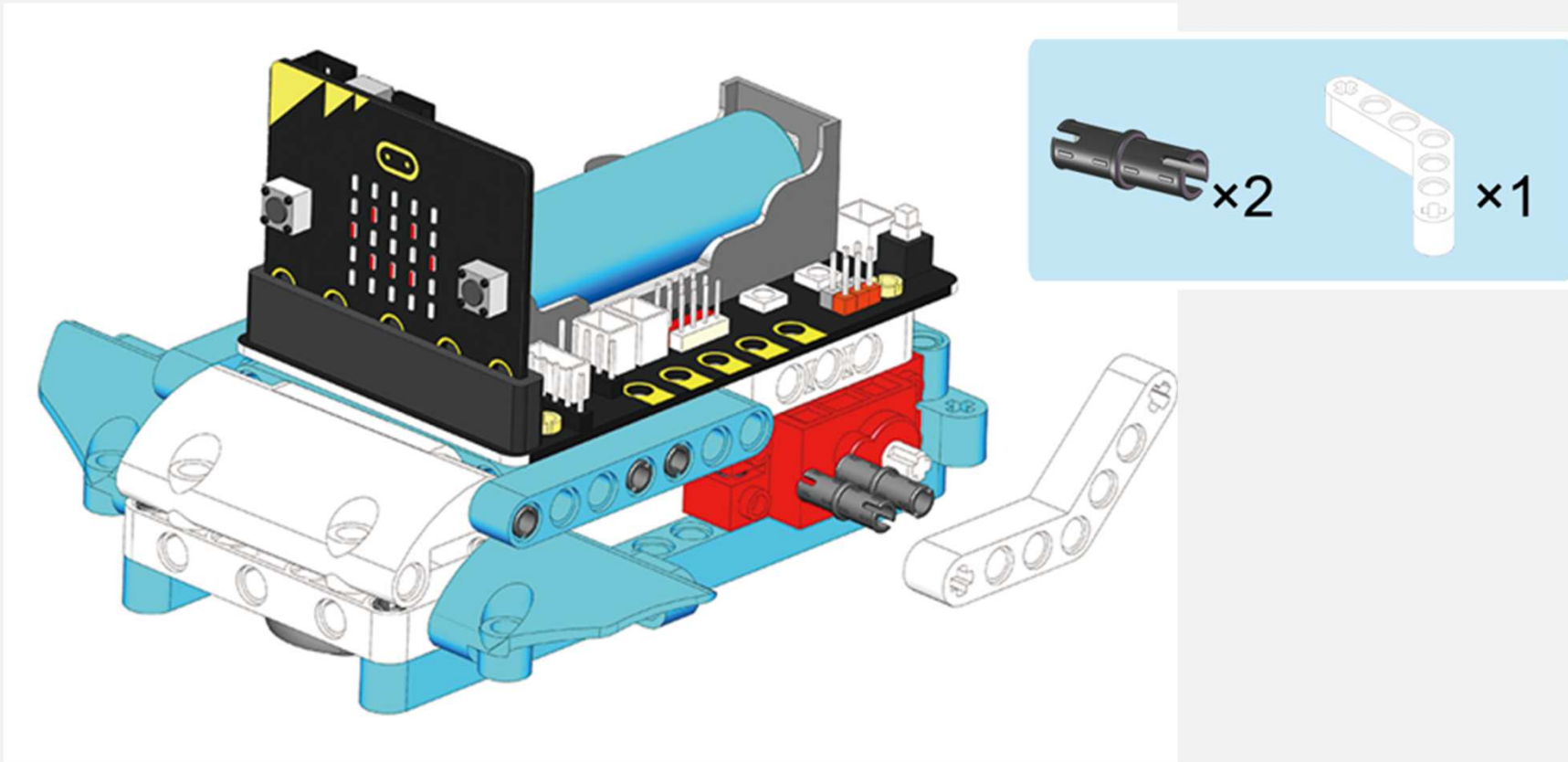

Step 19

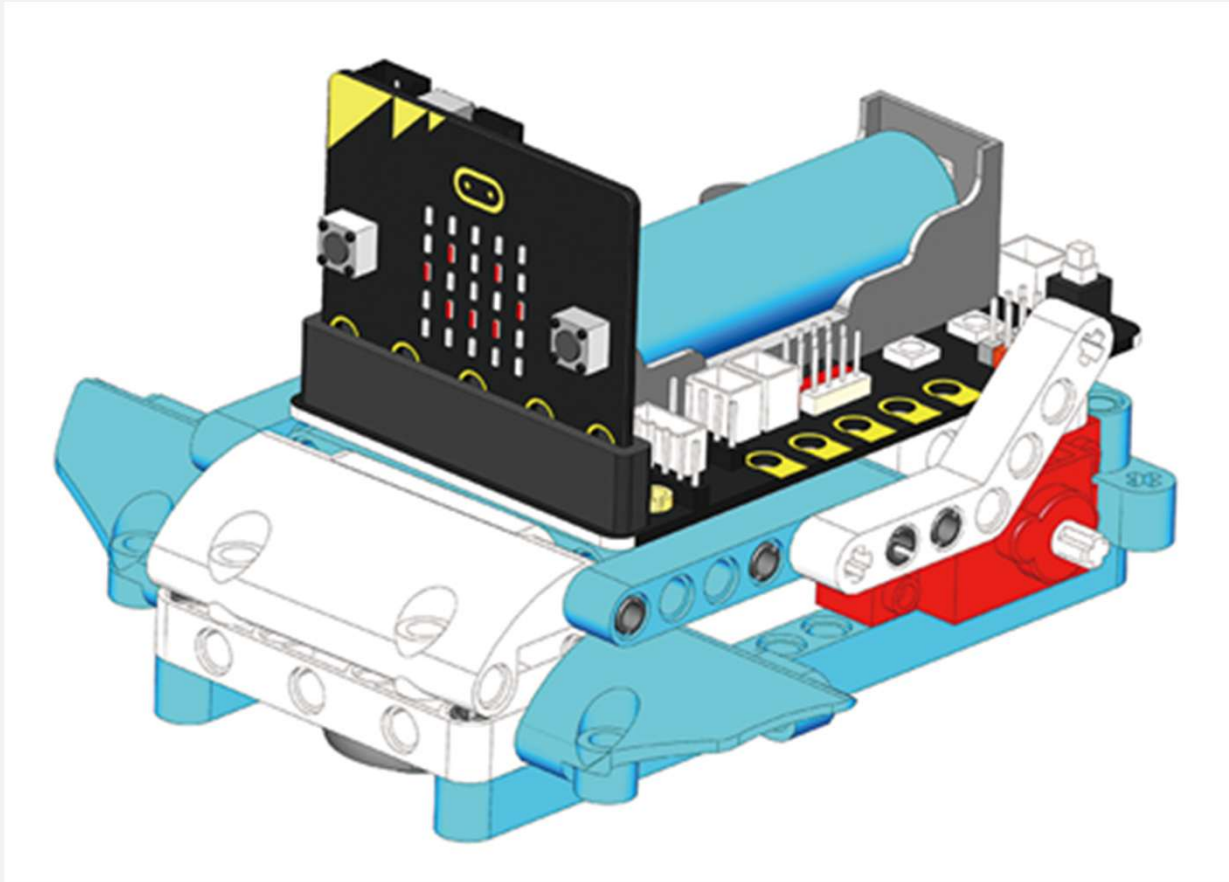

Step 20

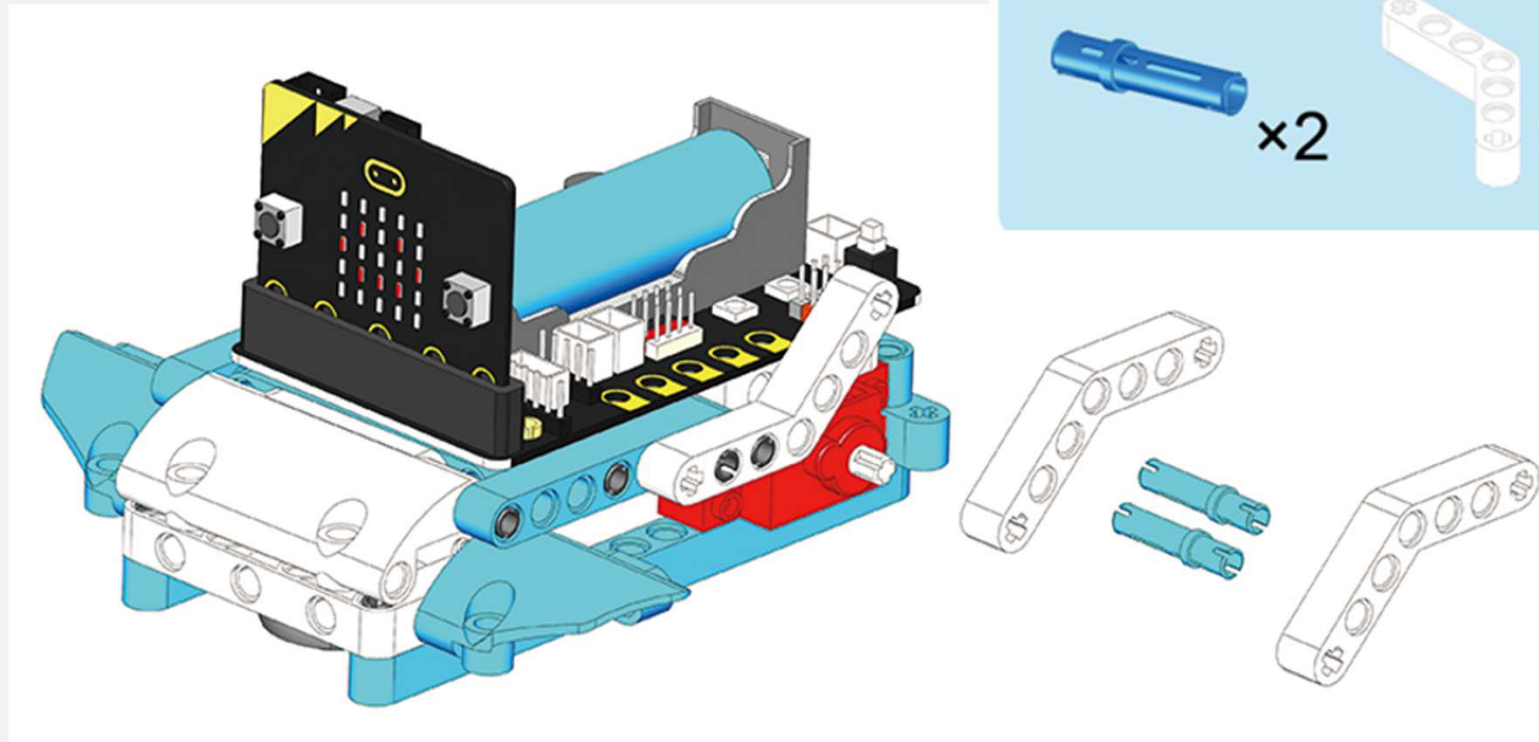

Step 21

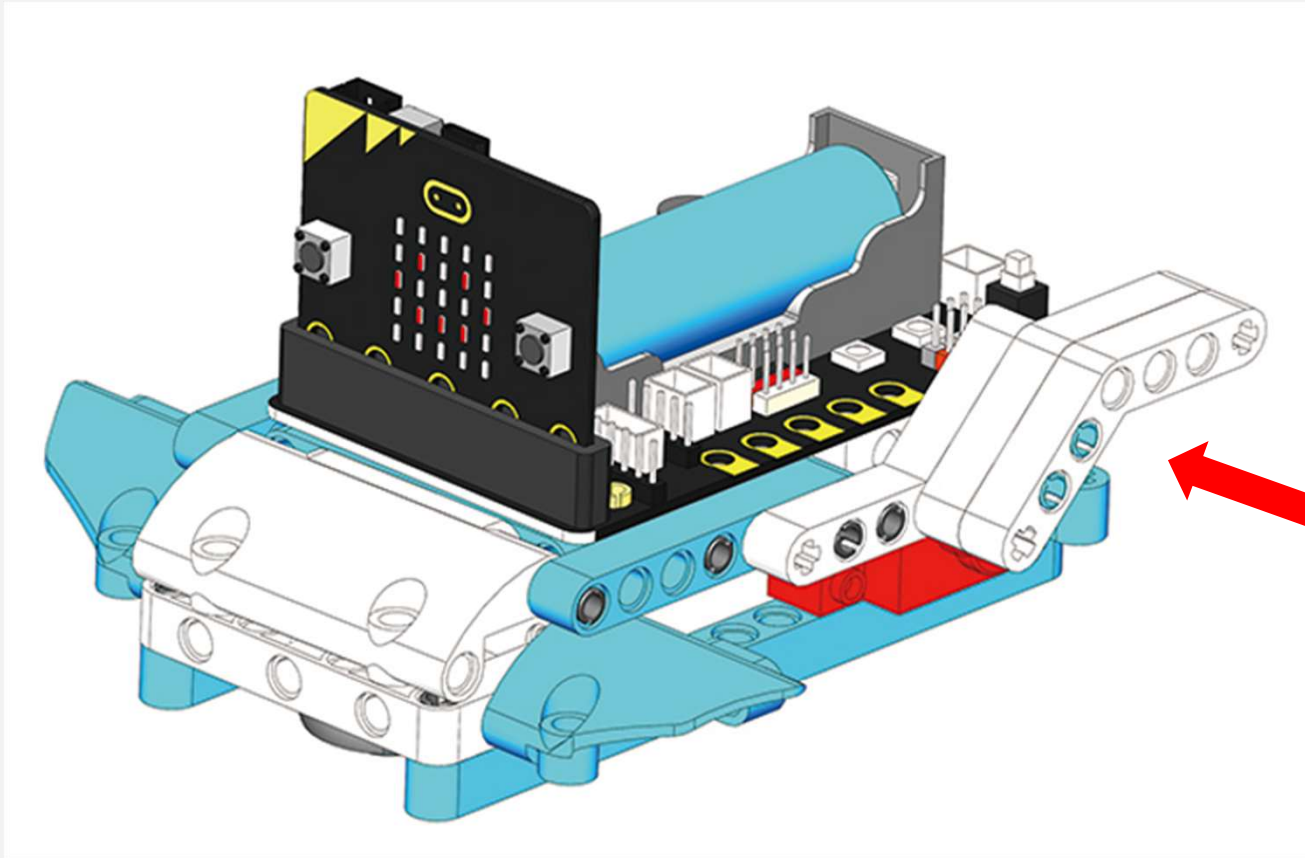

Step 22

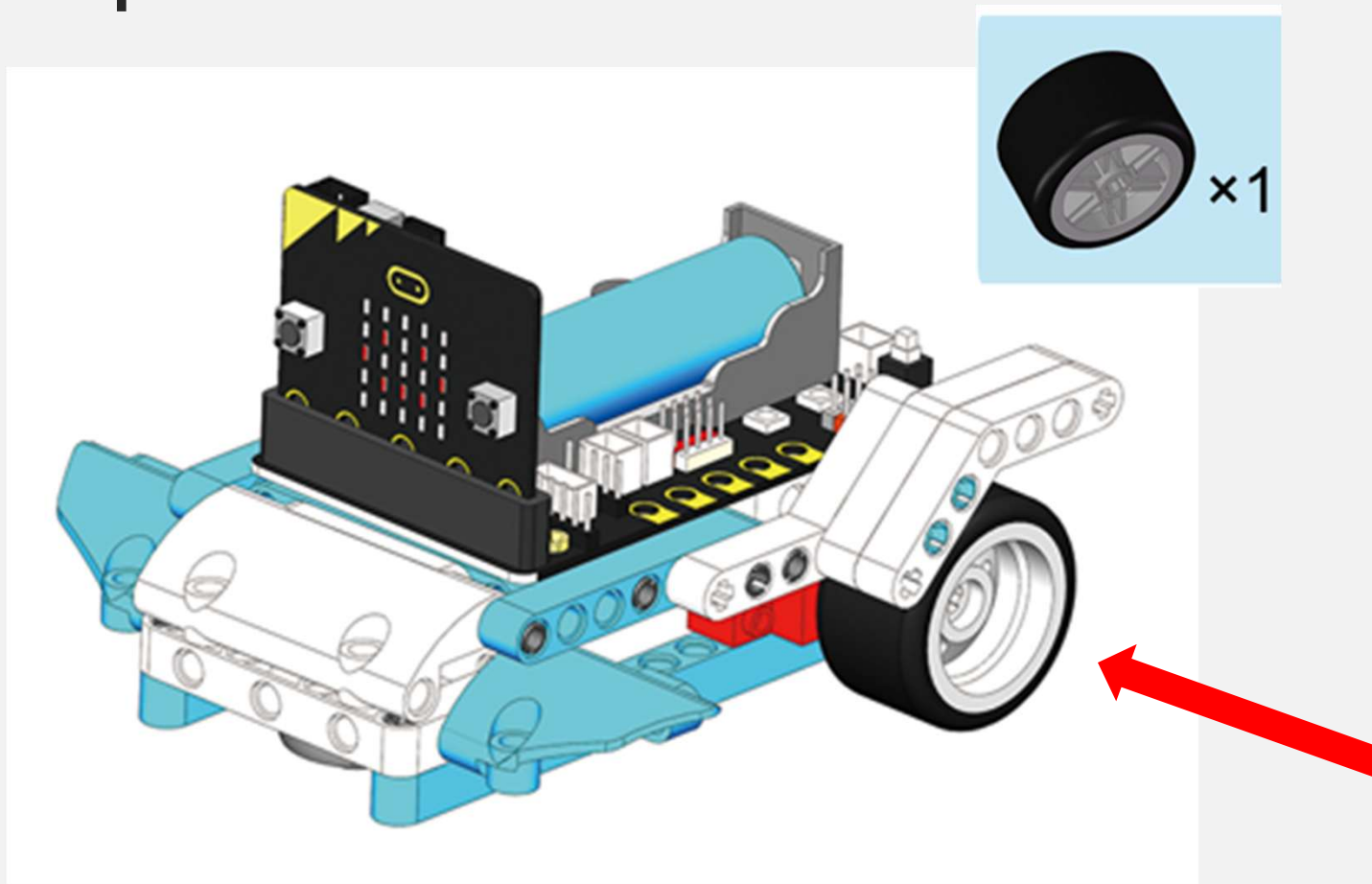

Step 23

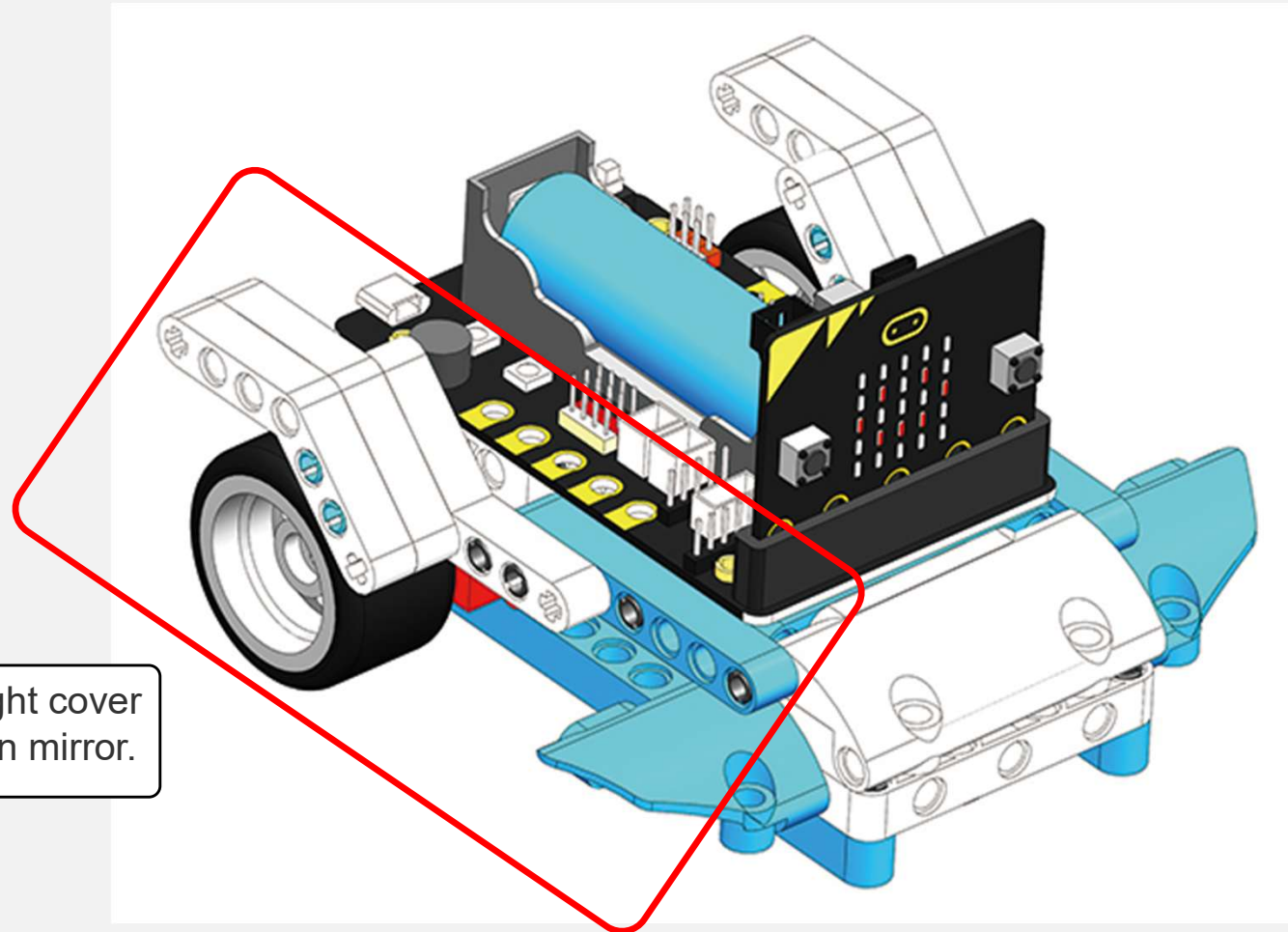

Build the right cover
and wheel in mirror.

Pretty Car (Robot Base)

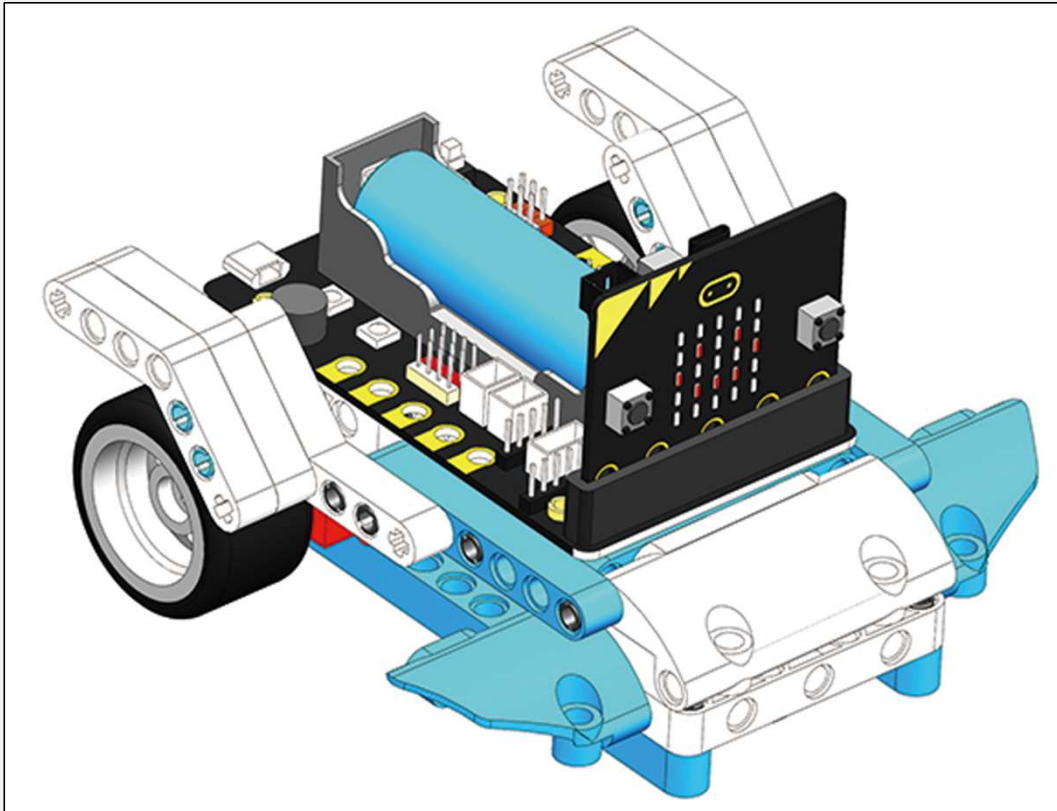

Build a Clipper for your Robot

Servo Calibration (Set S5 to 135° at start)



S5

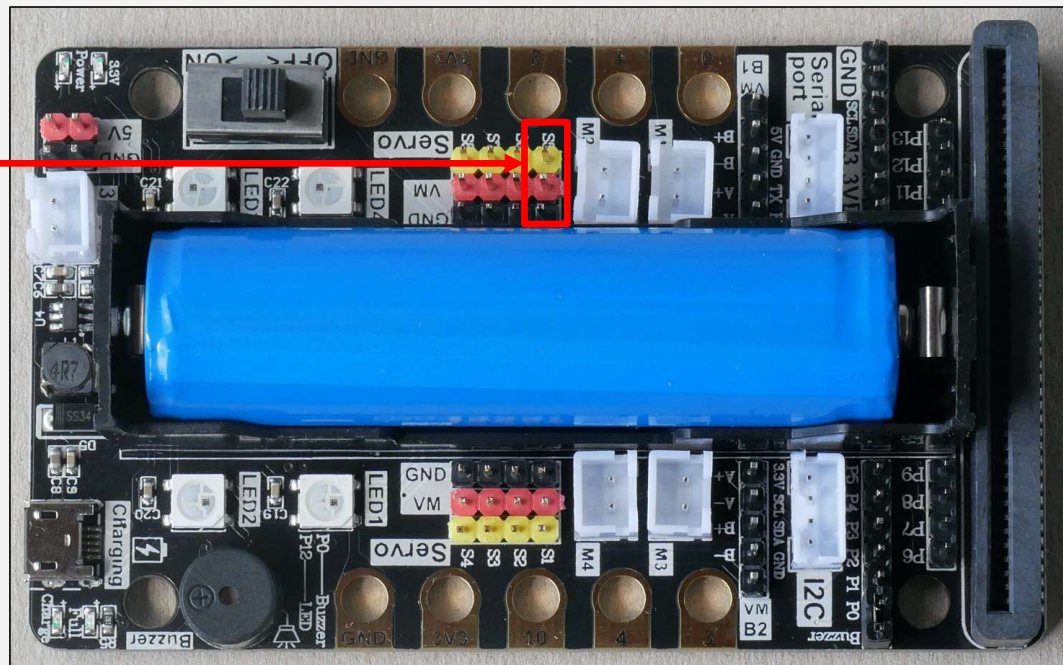

Then plug in a 270° servo (gray) in S5.

Servo Calibration (Set S5 to 135° at start)

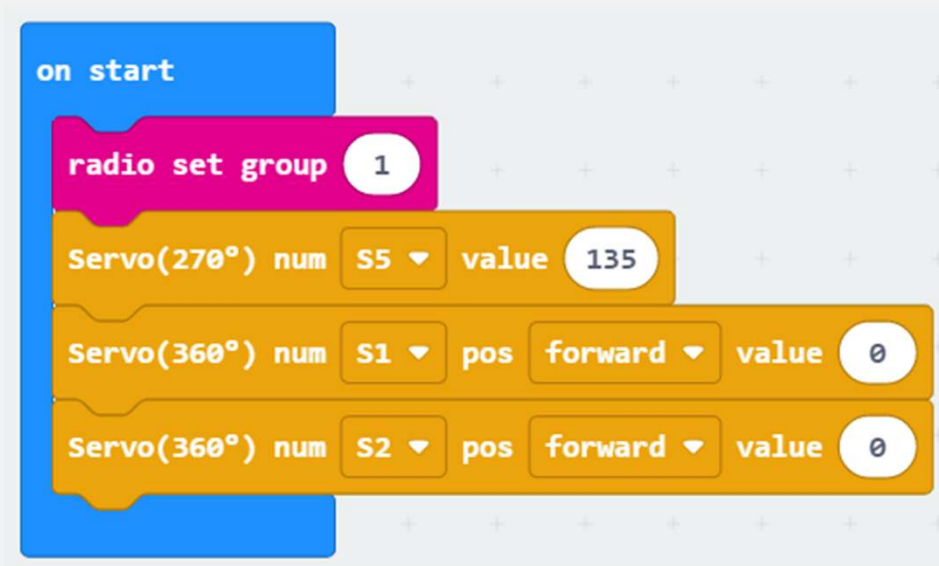

Let's set your S5 to 135° at start before you proceed to build your clipper.

And 135° will be your clipper open point.

Clipper - Step 1

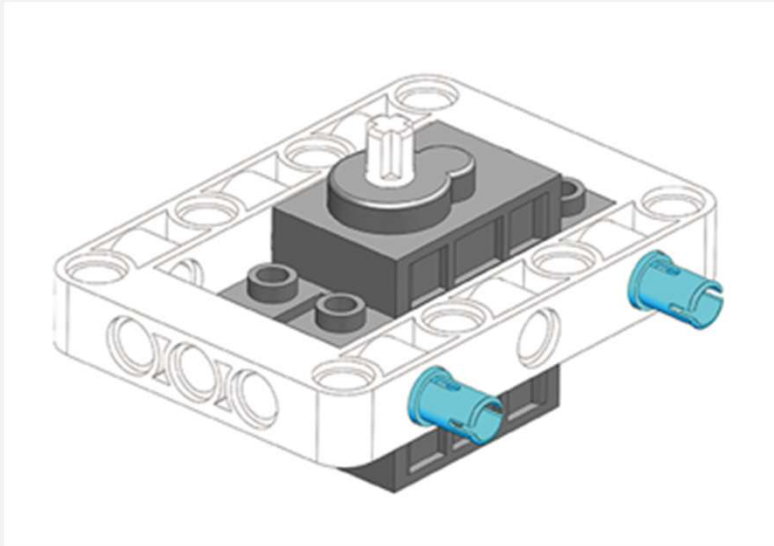
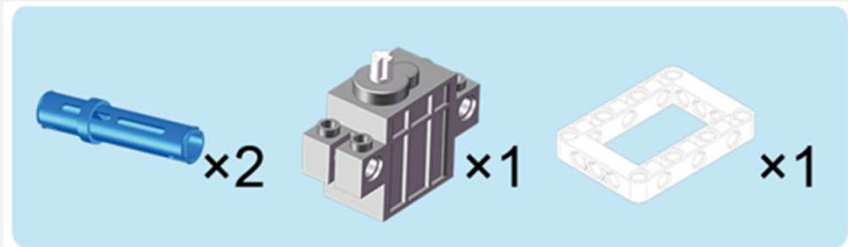



Clipper - Step 2

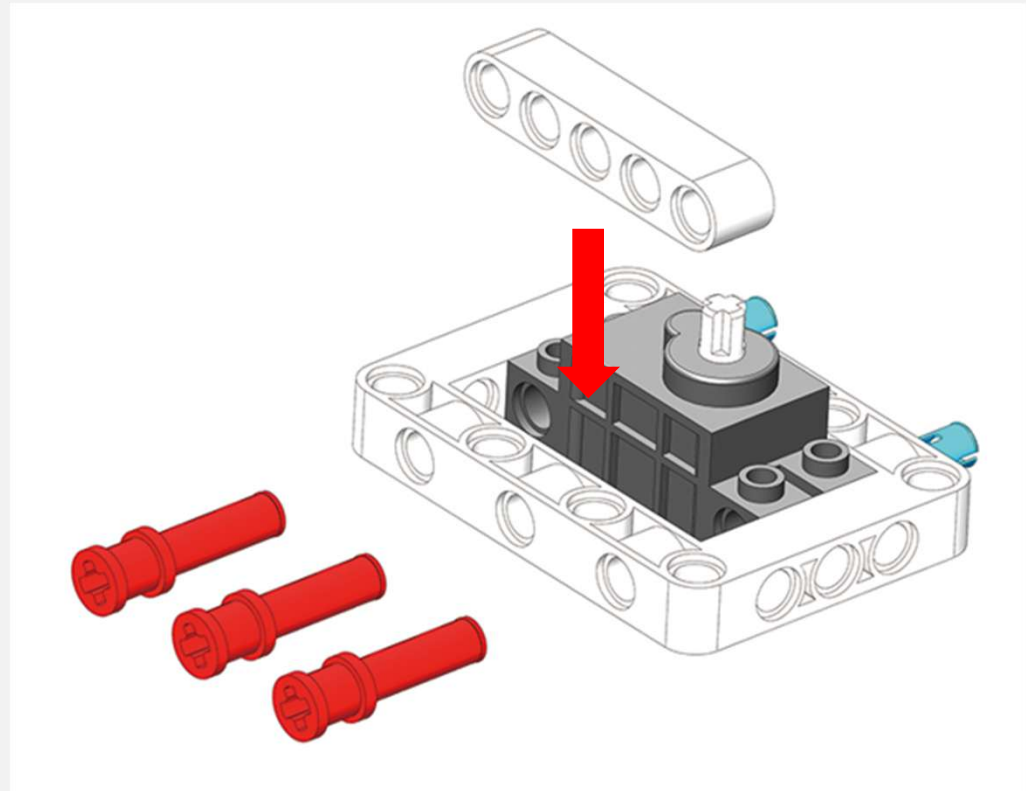
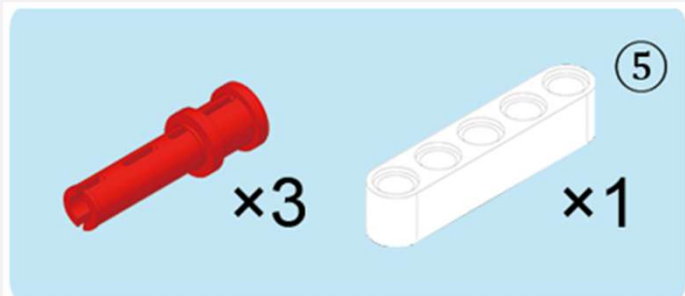

Clipper - Step 3

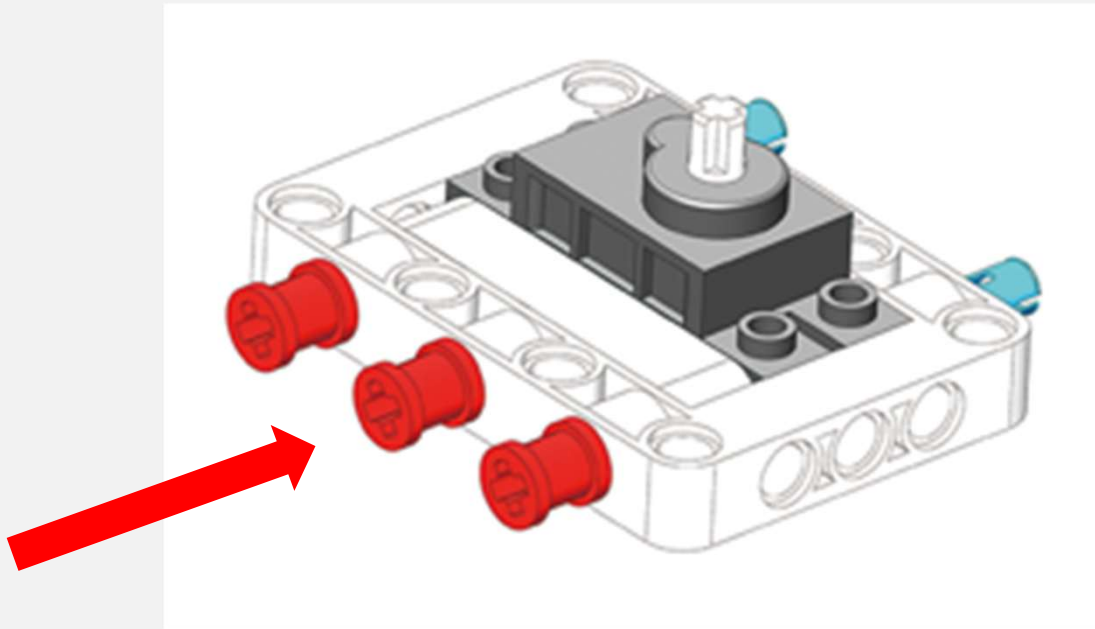

Clipper - Step 4

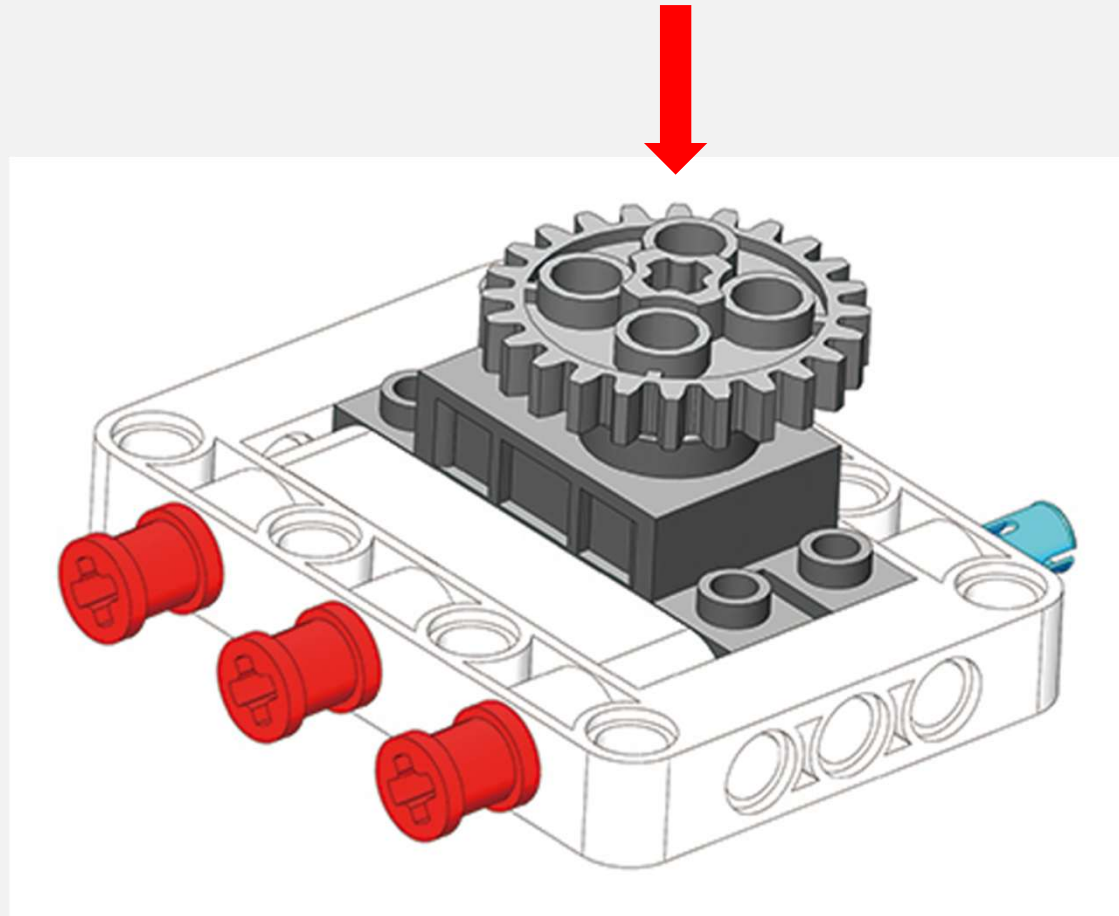
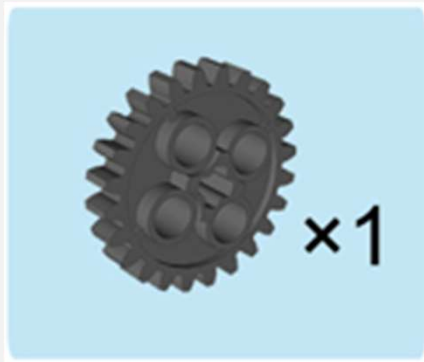



Clipper - Step 5

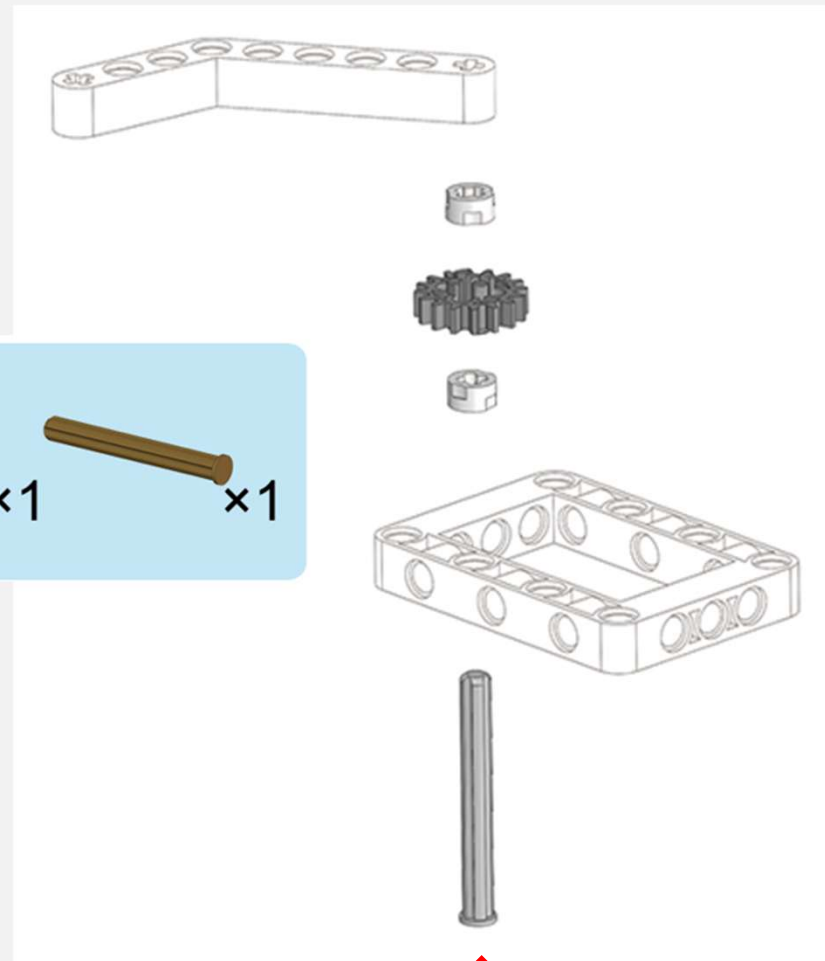
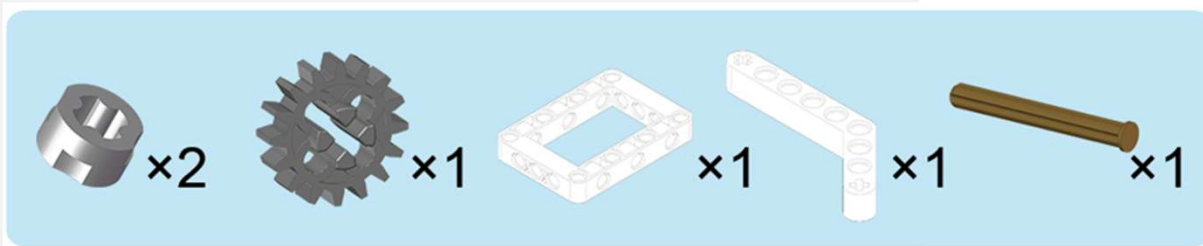

Clipper - Step 6

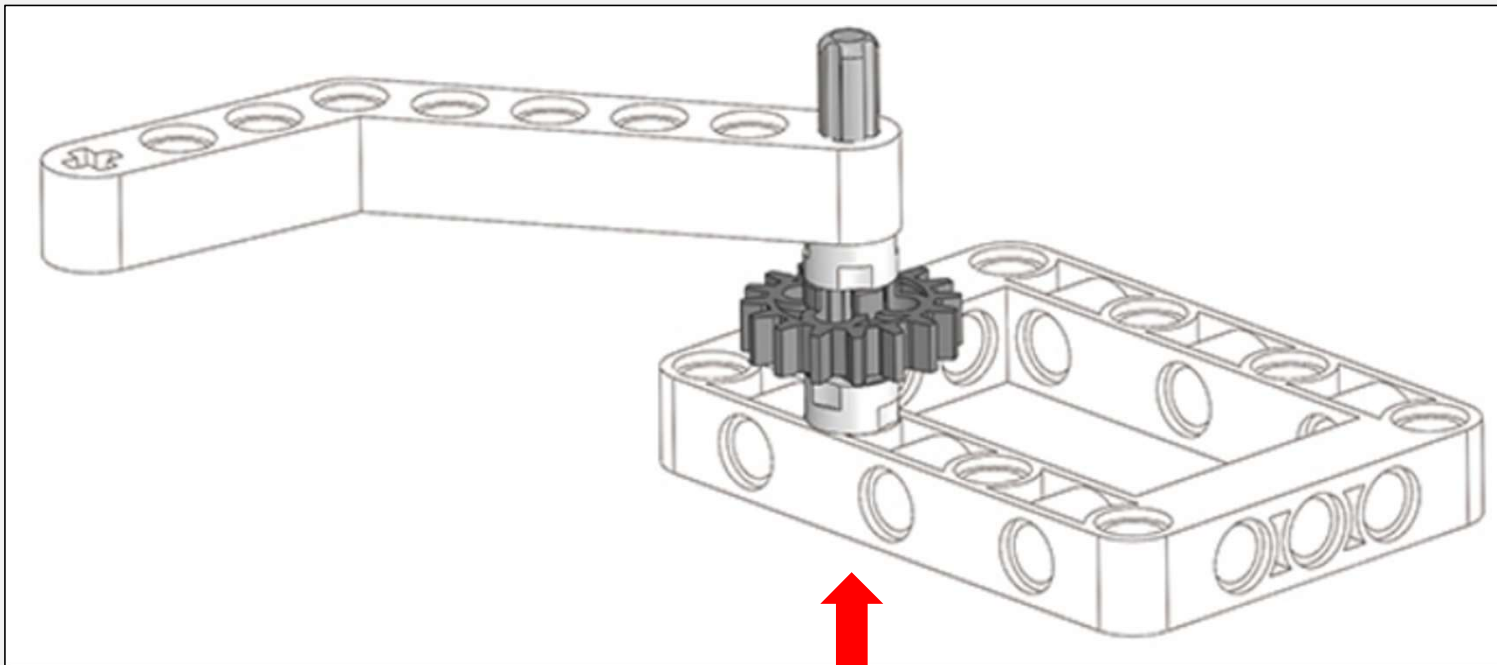



Clipper – Step 8

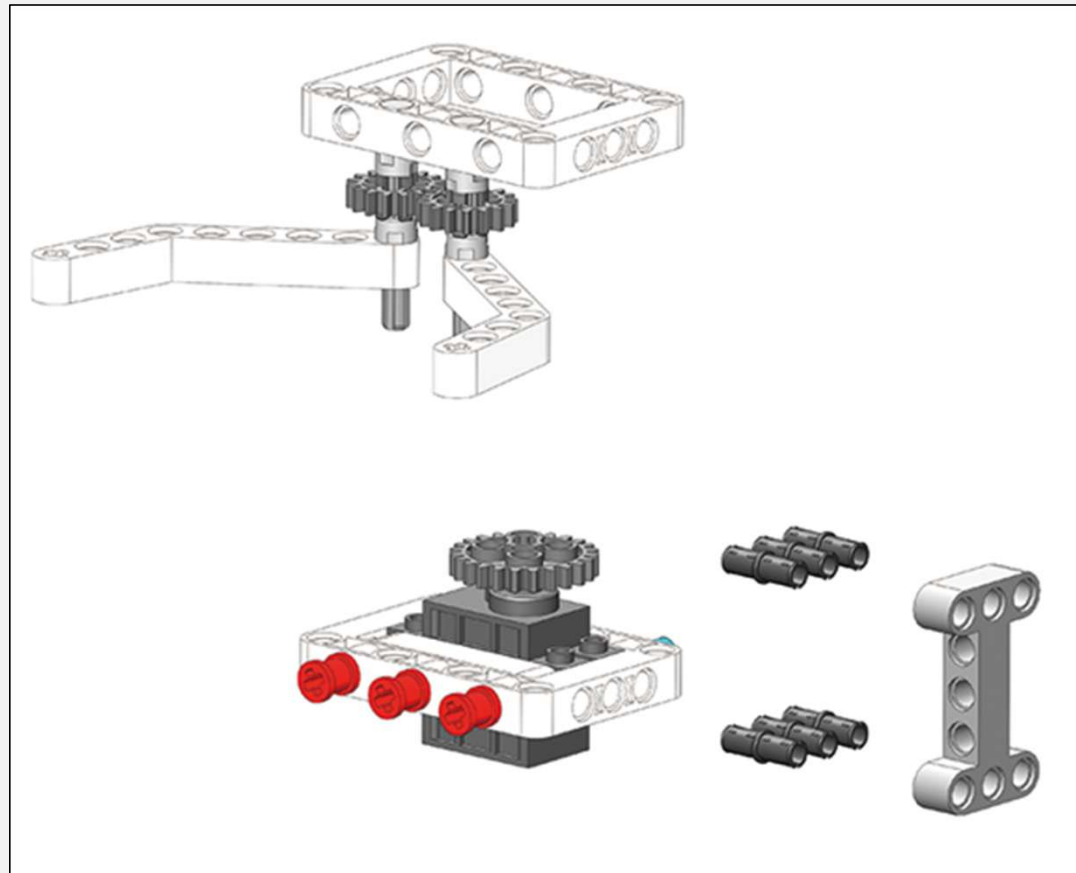
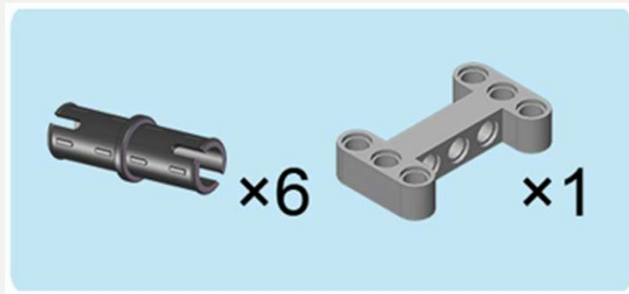

Clipper – Step 9

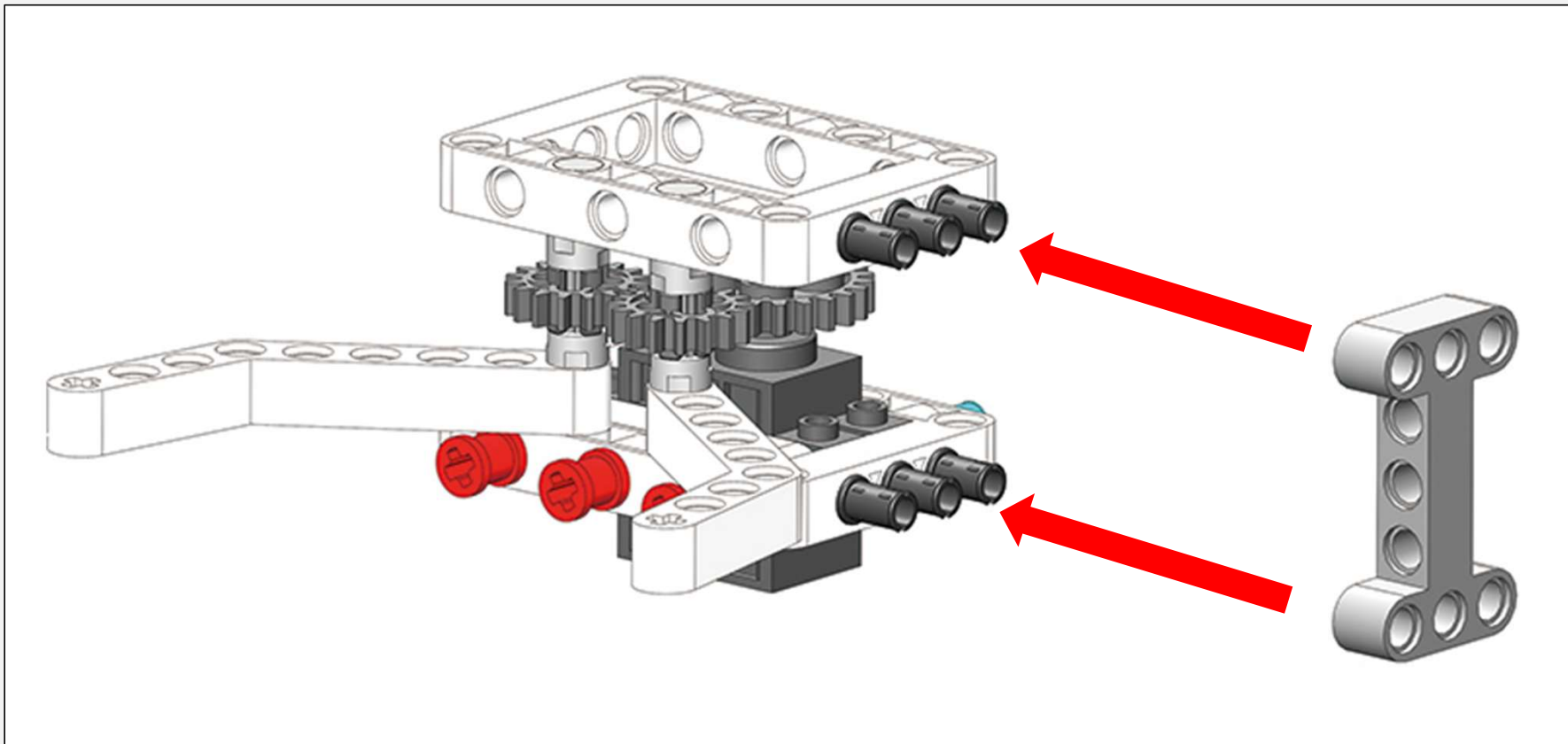

Clipper – Step 10

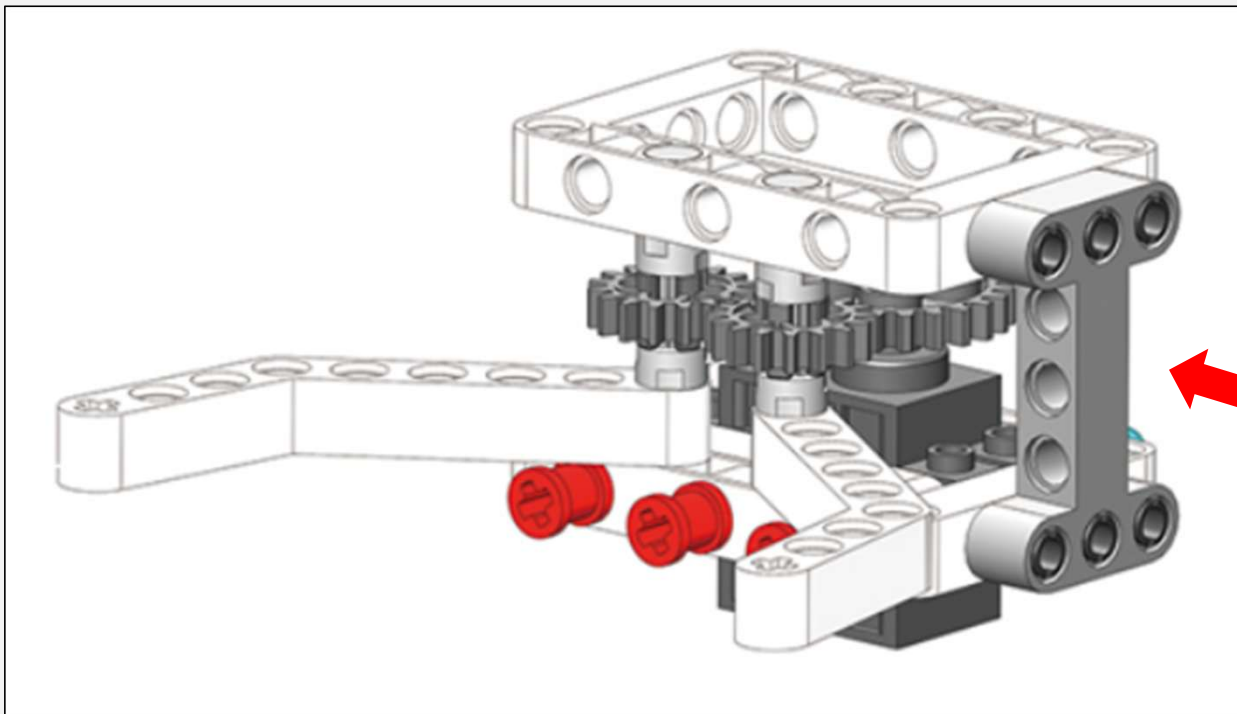

Clipper – Step 11

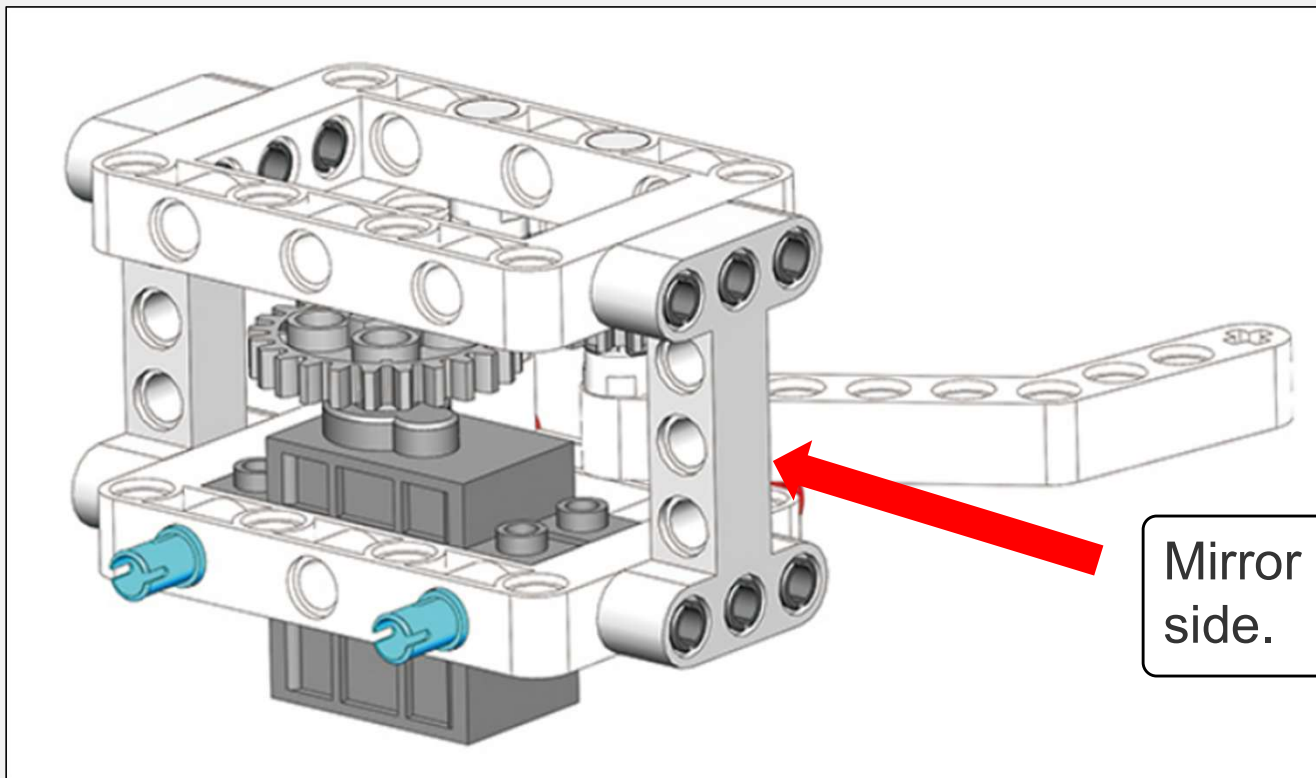

Mirror another side.

Install Clipper to your Robot

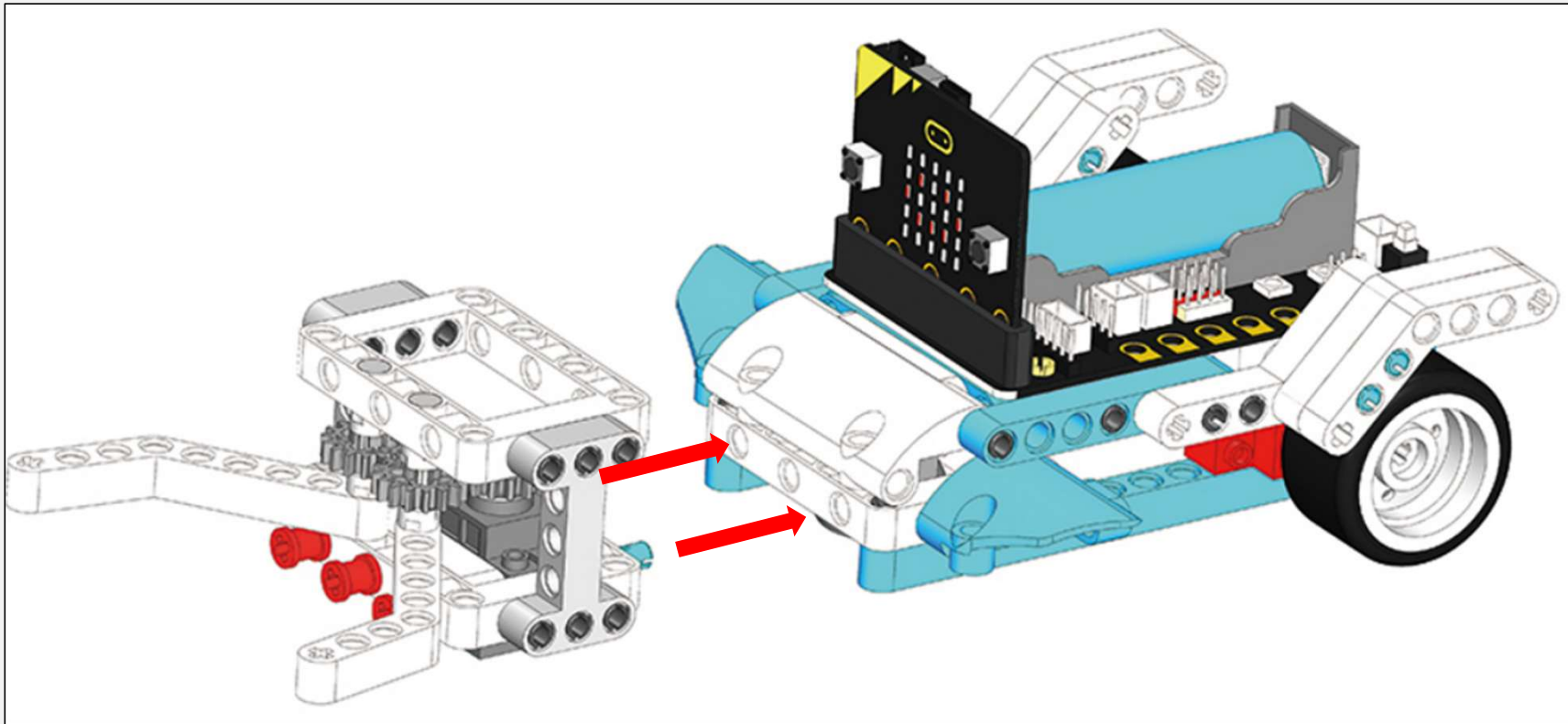



Clip Robot

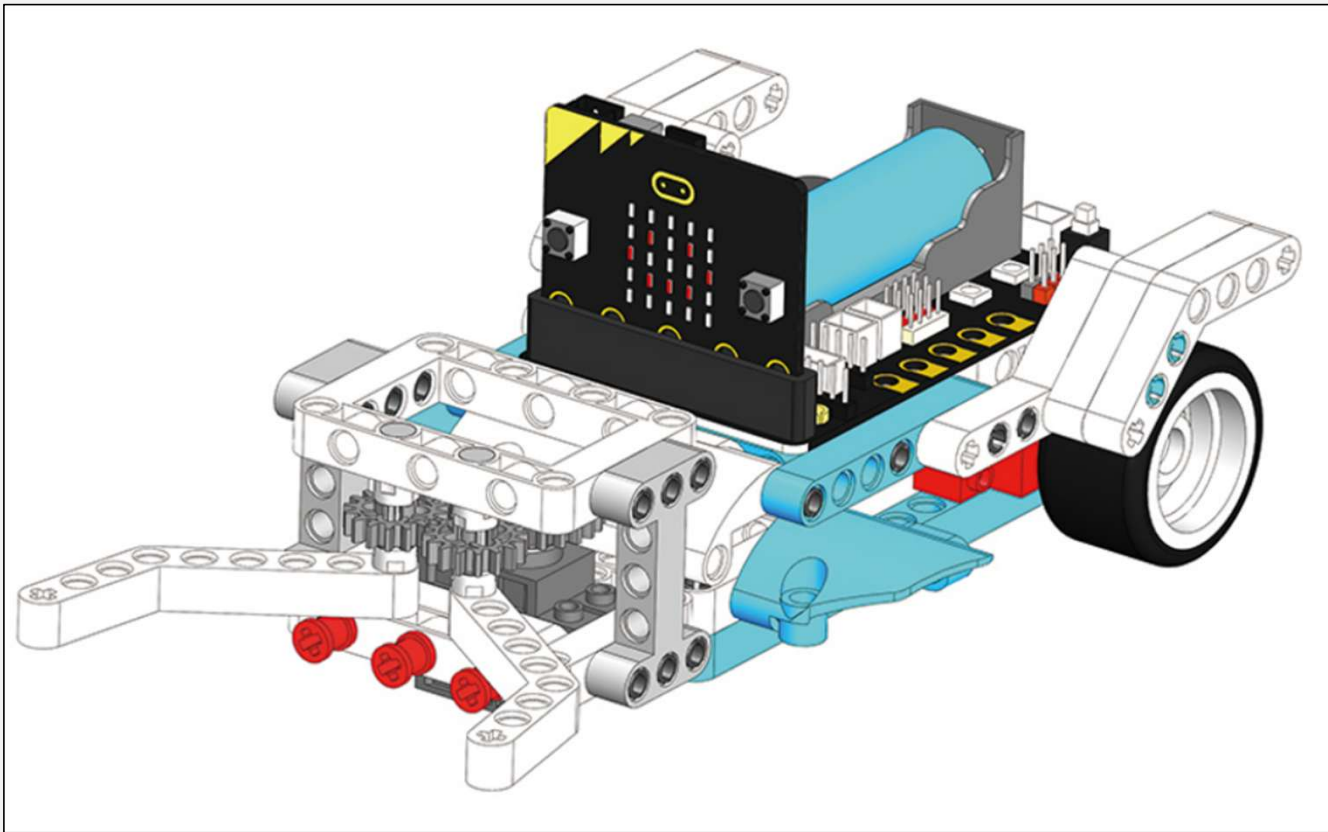

Program your Clip Robot

Code your Remote Controller



Remote Control



Let's program our remote controller first.

At first, we need to set radio group, please select a number from 0 – 255.

I will be using 1 as an example.

The radio group is served as a channel for your microbit to communicate via radio signal. So your Clip Robot should be listening to the same channel to work.

Code your Remote Controller

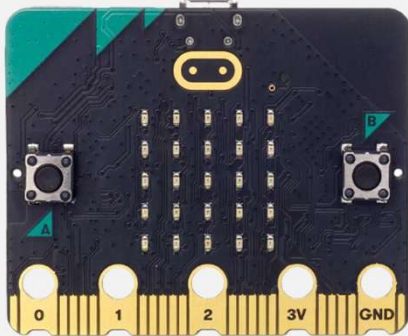

Remote Control

```
on start
  radio set group 1

forever
  if button A+B is pressed then
    +
```

Let's add a condition that when your button A and button B are pressed together, I will send a signal through radio to other microbit with the same group.

Code your Remote Controller

```
on start
  radio set group 1
```

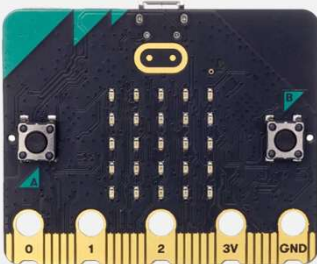

Remote Control

```
forever
  if button A+B is pressed then
    radio send string "forward"
  else if button A is pressed then
    radio send string "left"
  else if button B is pressed then
    radio send string "right"
  else
    radio send string "stop"
```

Then we add in different trigger to send different strings.

Then your remote controller is done.

Code your Clip Robot

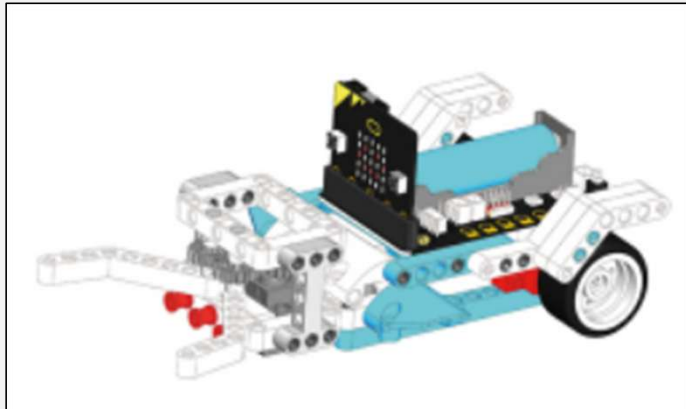

Clip Robot

Now is the time to code your mobile shooter to do action when receiving strings via radio from the remote controller.

MakeCode Programming

First, we need to connect the micro:bit to the computer by USB cable. The computer will pop up a USB flash drive and click on the URL in the USB flash drive: <http://microbit.org/> to enter the programming interface.

Add the Yahboom package <https://github.com/lzty634158/SuperBit> to program.

Or search [lzty634158/SuperBit](https://github.com/lzty634158/SuperBit) in the Microbit extension.

Superbit Extension

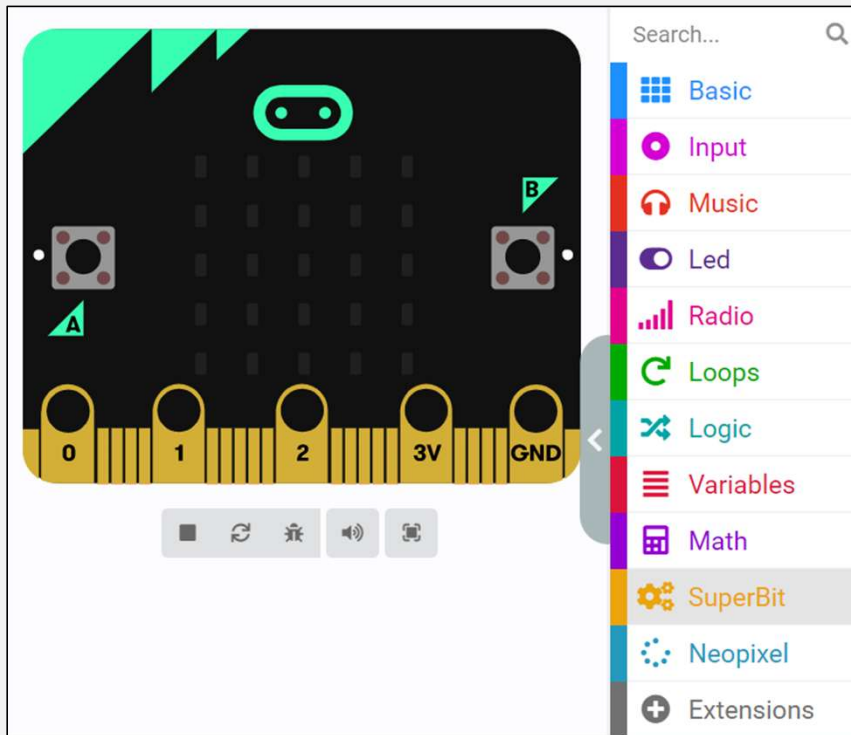

After importing the superbite extension, you will see **SuperBit** and **Neopixel** in your coding blocks.

MakeCode Programming

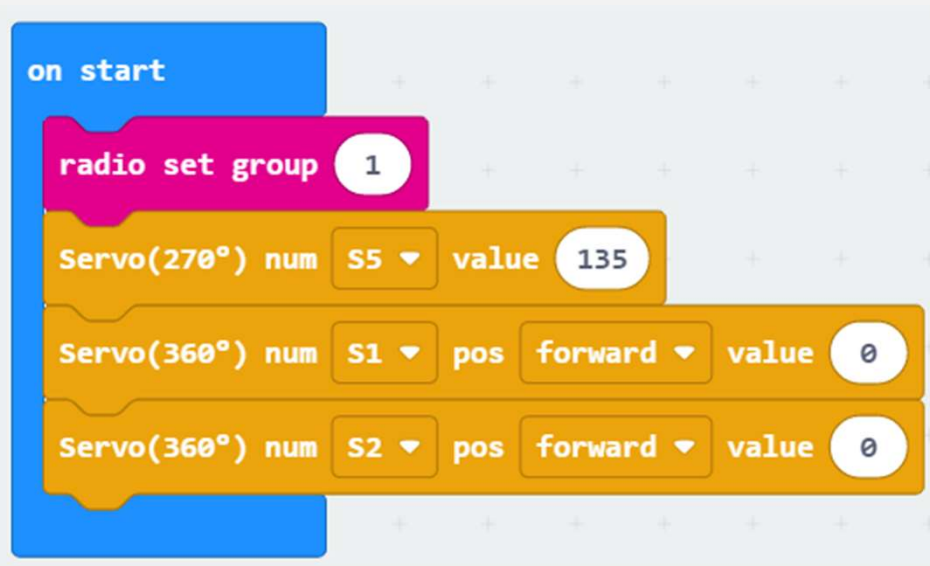

Program our starting state of our servos. And also set the radio group to the group that you set on your remote controller.

****You can use your last lesson's program.**

****We just need to add the actions for received signals from the remote controller.**

Make a Function - Move Forward



To make our program easy, we better make functions for our move forward, turn right, turn left and move backward as well as grabbing.

Let's start with Move Forward.

****You can use your last lesson's program.**

****We just need to add the actions for received signals from the remote controller.**

Make a Function

```
function moveBackward  
  Servo(360°) num S1 pos reverse value 50  
  Servo(360°) num S2 pos forward value 50
```

```
function turnLeft  
  Servo(360°) num S1 pos forward value 50  
  Servo(360°) num S2 pos forward value 50
```

```
function turnRight  
  Servo(360°) num S1 pos reverse value 50  
  Servo(360°) num S2 pos reverse value 50
```

```
function stop  
  Servo(360°) num S1 pos forward value 0  
  Servo(360°) num S2 pos forward value 0
```

**You can use your last lesson's program.

**We just need to add the actions for received signals from the remote controller.

Let's program for the remaining functions.

Make a Function – Grab & Release

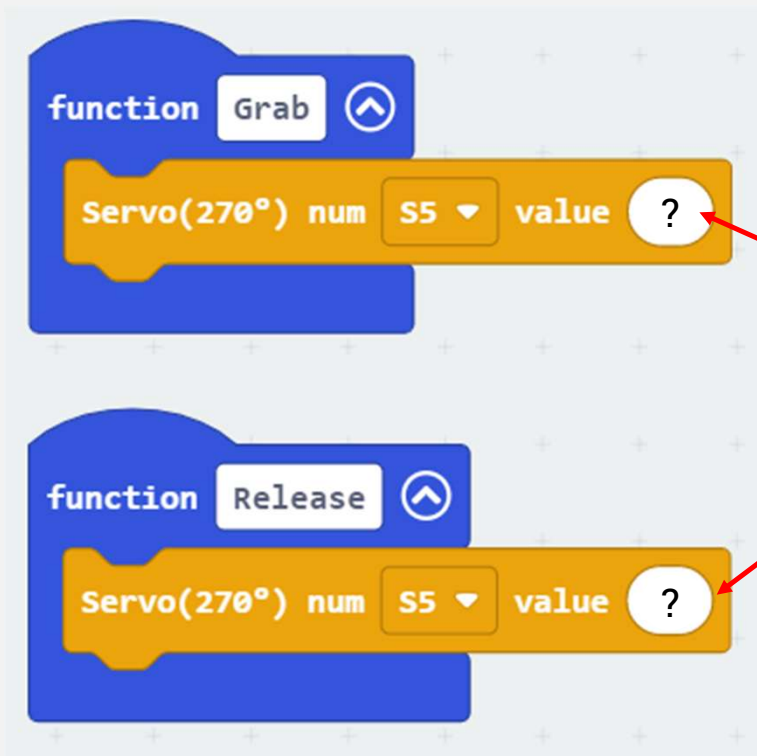

As you have set your grabber starting position.

To make grab and release functions, you need to set your S5 servo to different position for grabbing and releasing. And now is time for you to test yourself which position works best for your clip robot.

Code your Clip Robot's actions

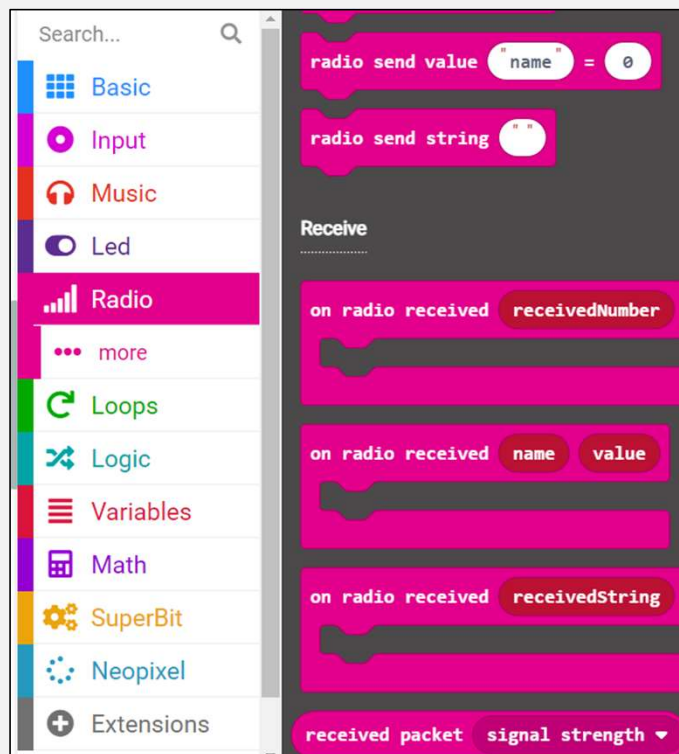

Let's take the block "on radio received **receivedString**" for the actions when received the signals from other microbit.

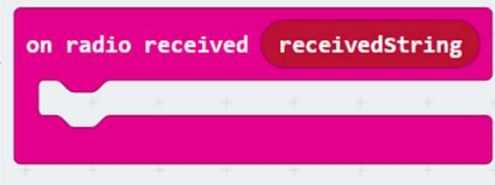

Code your Clip Robot's actions

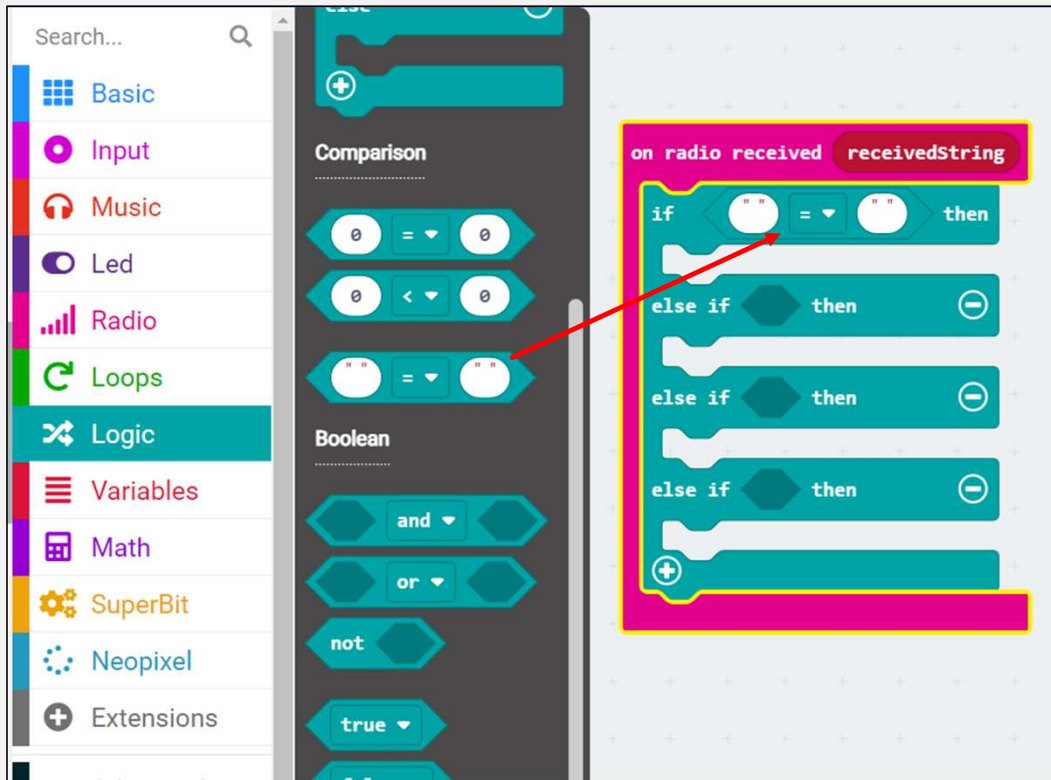

Since we got 4 possible strings received from our controller, we need to set 4 **conditions** inside.

As now we are comparing the string, not the number, make sure your comparison operator is using the **string comparison** with the quotation mark ("").

Code your Clip Robot's actions

```
on radio received receivedString
  if receivedString = "forward" then
    call moveForward
  else if then
  else if then
  else if then
  +
```

We will need to check what string is received and set if the string received is "forward", then we want to call the **moveForward** function.

Code your Clip Robot's actions

```
on radio received receivedString
  if receivedString = "forward" then
    call moveForward
  else if receivedString = "right" then
    call turnRight
  else if receivedString = "left" then
    call turnLeft
  else if receivedString = "stop" then
    call stop
```

Complete the actions for remaining functions.

Please make sure the strings must be totally same (case sensitive) from the strings that you program with your remote controller.

MakeCode Programming

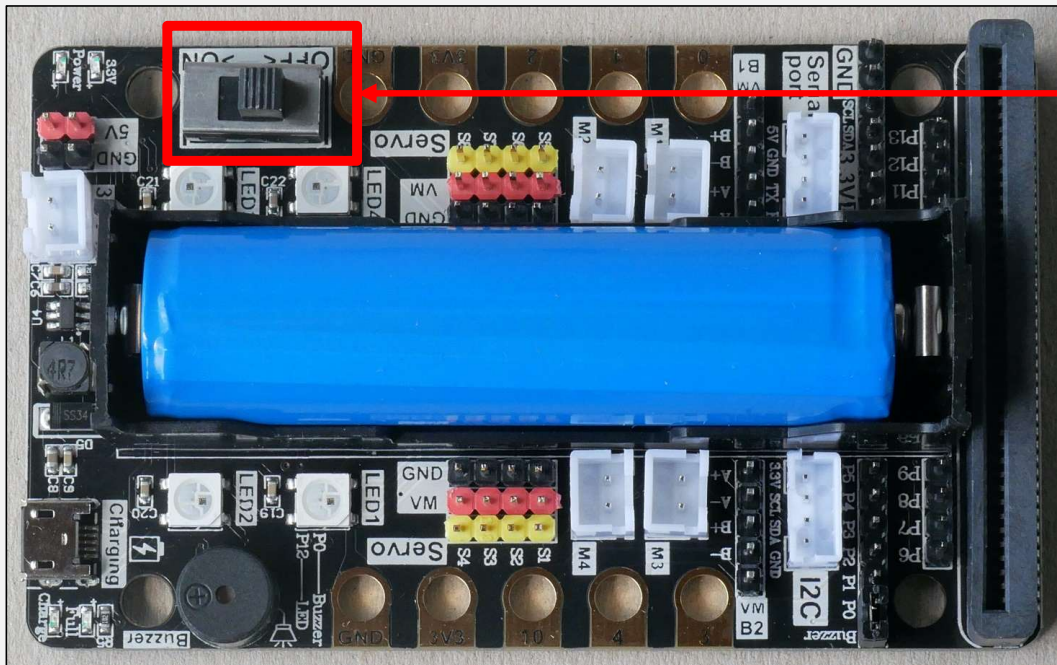

After the program is downloaded, turn on the SuperBit with the power switch to turn on your clip robot.

Phenomenon

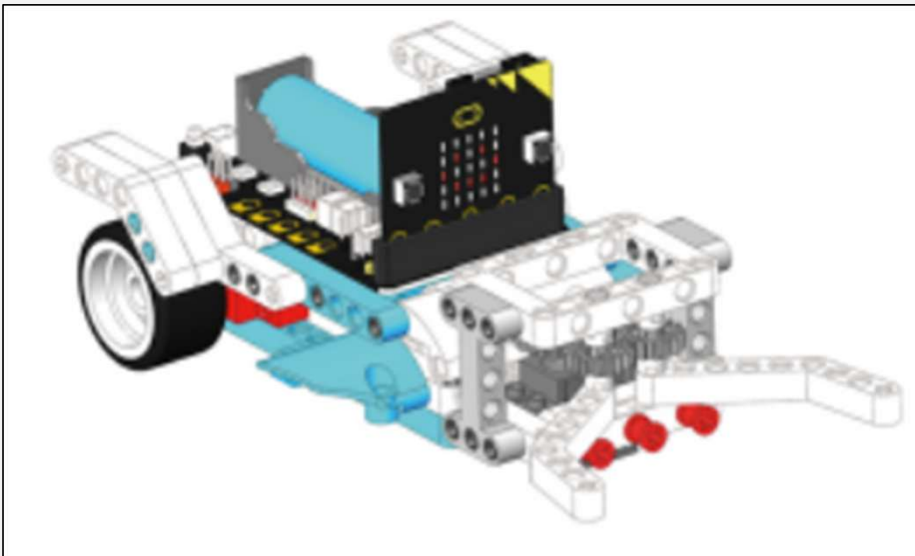

30 Points

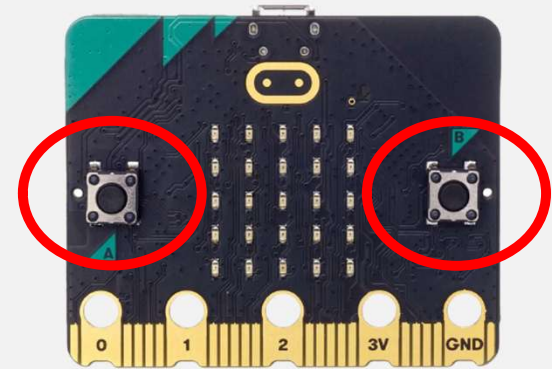

Connect your remote controller to your laptop to power on and try to interact with the button A & button B, then observe what happen to your Clip Robot. You now should be able to control your Clip Robot with forward, left and right.

CHALLENGE

for : Lesson 3

L3 – Challenge 1

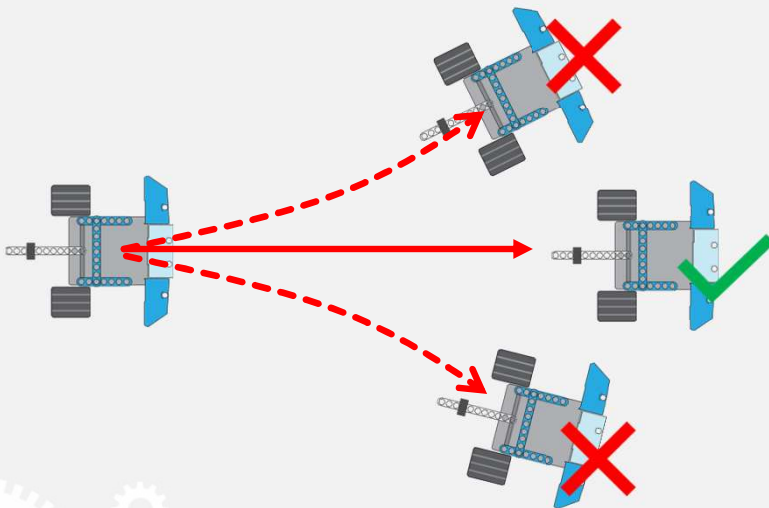

Program your Clip Robot to have full movement functions:

1. Move Forward (Tune it to be straight)
2. Turn Right
3. Turn Left
4. Move Backward (Tune it to be straight)

30 Points

L3 – Challenge 2

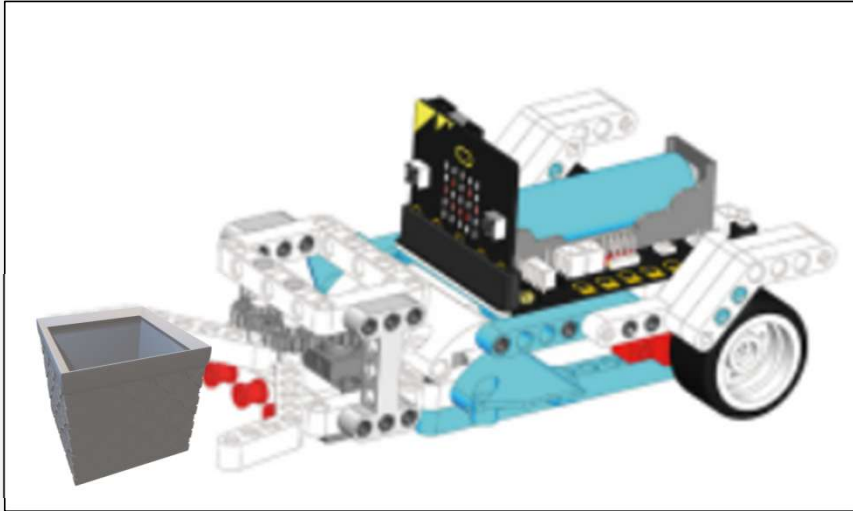

30 Points

Add 2 more functions for your clip robot:

1. Grab
2. Release

You may need to adjust your robot clipper and calibrate your servo motor before you start coding.

****Go to your input coding blocks and see what are the inputs can be used as a trigger.**

L3 – Robot Mini Game

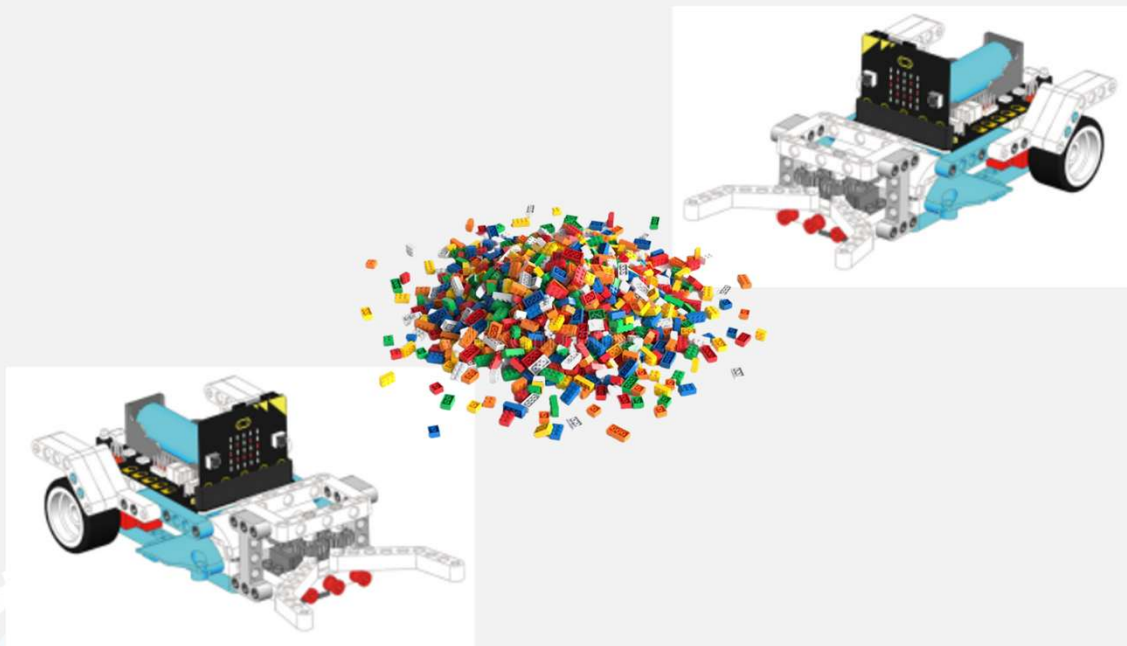

There are plenty of resources (lego bricks) on an island, and there are 3 companies craving for the resources due to scarcity.

The resources are with different grades:

Red – Ruby – (100 coins each)

Blue – Diamond (75 coins each)

Green – Emerald (30 coins each)

Other colors – lower grade resources (10 coins each)

L3 – Robot Mini Game

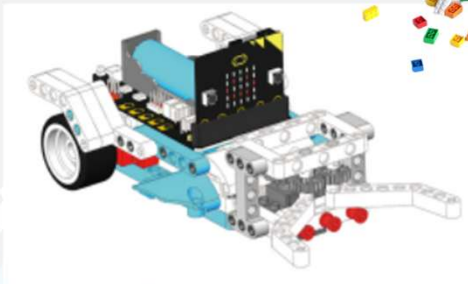
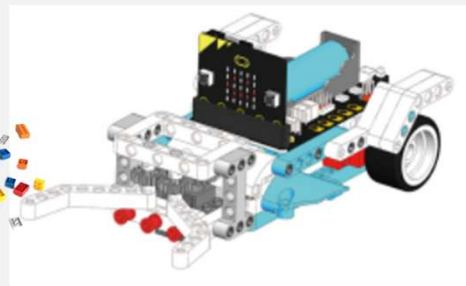
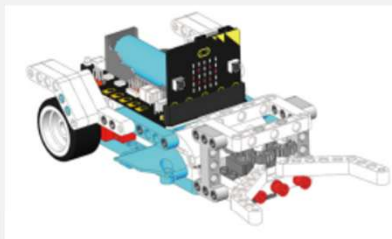

Each island (table) got 3 groups.

You may redesign your clip robot to make it mine for efficiently.

Group with the highest values of resources will be the winner of the island. Then will proceed to final competition with all winners of each island.

L3 – Robot Mini Game Rewards



Rewards:

- 1st Place – 100 points
- 2nd Place – 75 points
- 3rd Place – 50 points
- 4th - 6th Place – 20 points

L3 – Mission

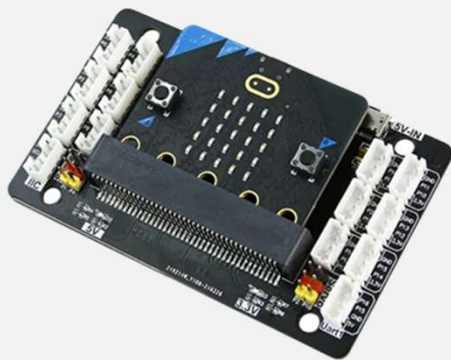

Can you use WOM modules as a controller and add in button as for grab function, and the rocker module as the movement control for the clip robot?