



Microbit Robotics Beginner Level 2

Lesson 8

TinkerCAD 3D Modelling

Presented by Advanced Superlogic Team

Today's Topic

- 1. Introduction to TinkerCAD 3D Software**
- 2. Understand TinkerCAD Interface**
- 3. Introduction to 3D Printer & Mechanism**
- 4. Measurement Unit in TinkerCAD**
- 5. Basic 3D Modelling Technique**

Learning Outcome

- 1. Able to create an account for TinkerCAD**
- 2. Understand how 3D Printer works**
- 3. Able to perform 3D modelling in TinkerCAD**
- 4. Able to convert 3D file to gx code and import to 3D printer for printing**

TinkerCAD 3D Modelling

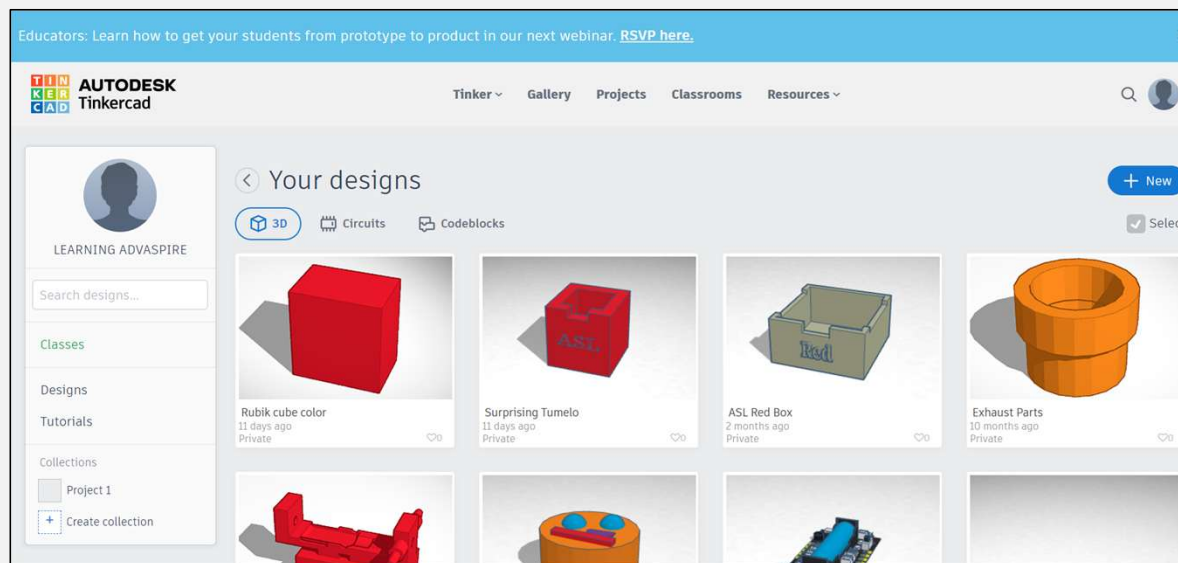

We kept building new models using the Lego bricks and WOM board from our Microbit Beginner Set.

Now we will use 3D printing to make a cover or the peripherals for our Robotics model.

And for beginner to start with 3D modelling, we will recommend TinkerCAD.

TinkerCAD

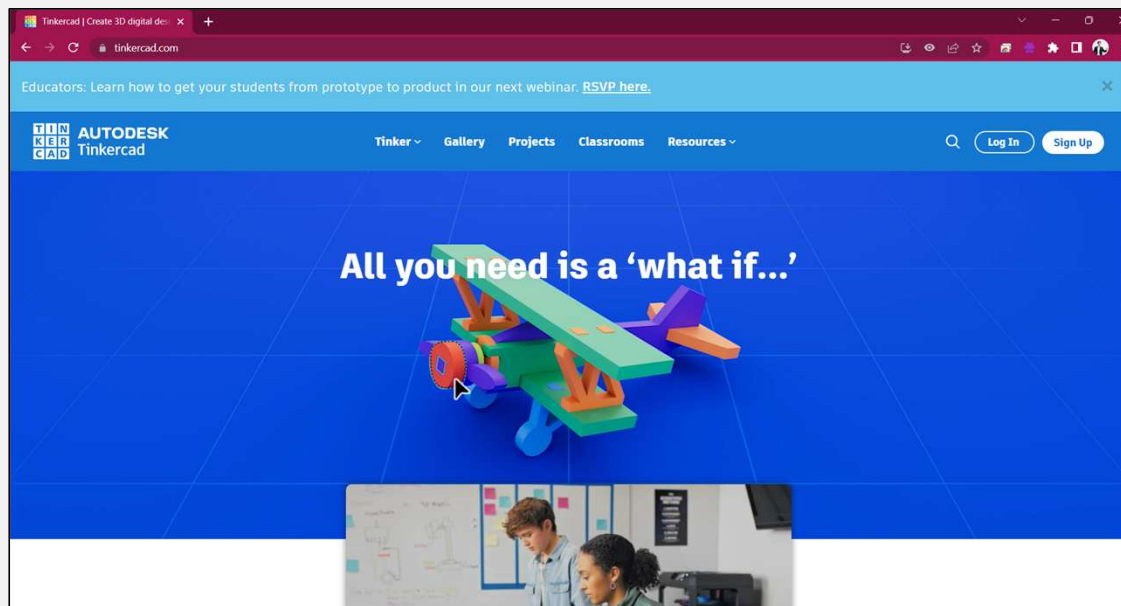

TinkerCAD is a web-application.
To open tinkercad, we can open <https://www.tinkercad.com/> from our browser.

TinkerCAD

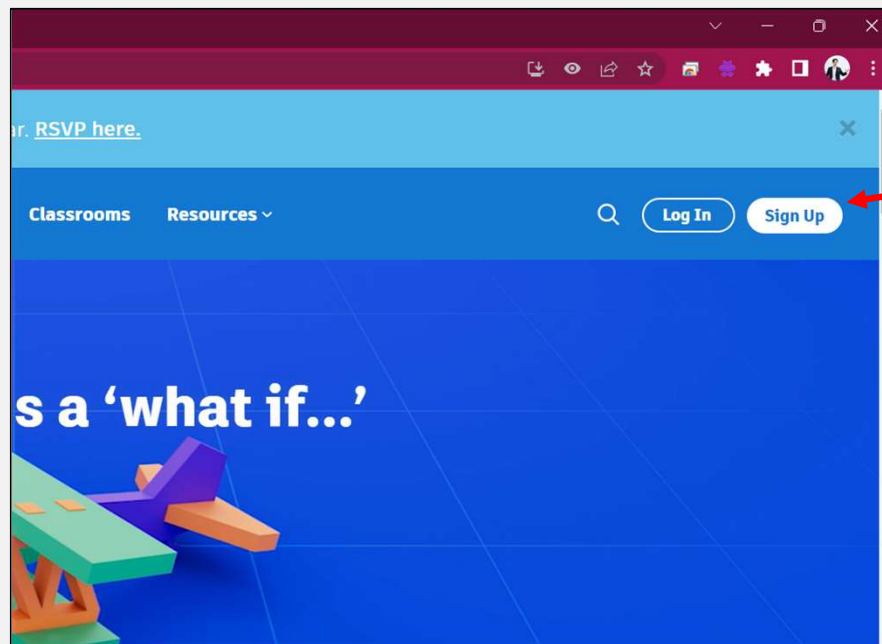

If you already have an account for TinkerCAD, you can click the “Log In” button on the top right corner.

If you haven’t had an account yet, you can select “Sign Up” to sign up for an account.

TinkerCAD – Sign Up for an Account

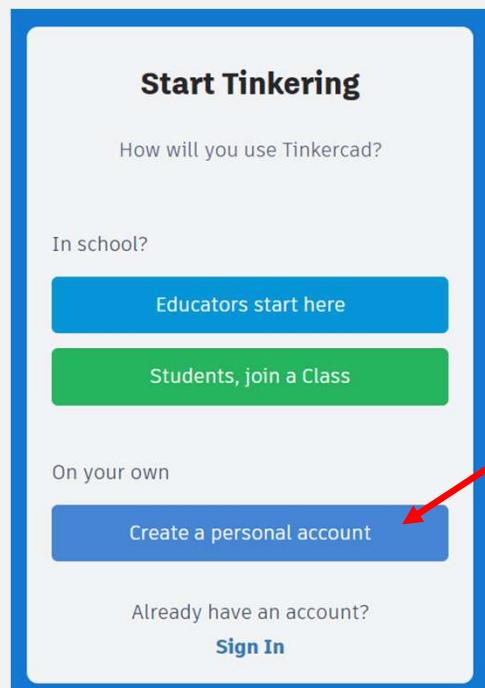
A screenshot of the TinkerCAD sign-up page. The page is titled "Start Tinkering" and asks "How will you use Tinkercad?". Under the heading "In school?", there are two buttons: "Educators start here" (blue) and "Students, join a Class" (green). Under the heading "On your own", there is a blue button labeled "Create a personal account". At the bottom, there is a link for "Already have an account? Sign In". A red arrow points from a text box to the "Create a personal account" button.

You can select “Create a personal account” to start.

TinkerCAD – Sign Up for an Account

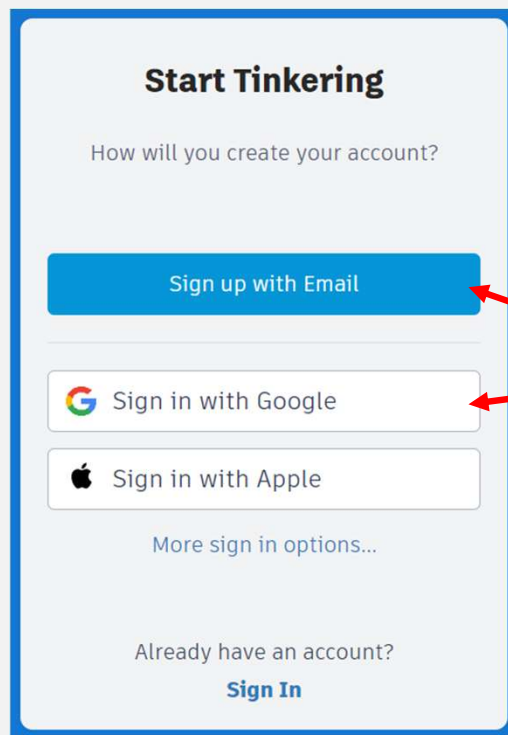
A screenshot of the TinkerCAD sign-up form. The form is titled "Start Tinkering" and asks "How will you create your account?". It features three main options: "Sign up with Email" (a blue button), "Sign in with Google" (a button with the Google logo), and "Sign in with Apple" (a button with the Apple logo). Below these is a link for "More sign in options...". At the bottom, there is a link for "Already have an account?" with a "Sign In" button.

You can either choose to sign up with your school email or you can choose to sign in with Google email.

TinkerCAD – Sign Up for an Account

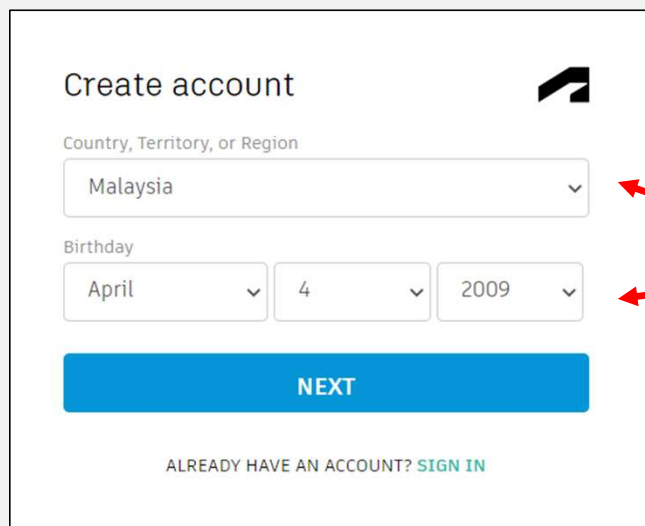
A screenshot of the TinkerCAD account creation form. The form is titled "Create account" and includes a TinkerCAD logo. It has a dropdown menu for "Country, Territory, or Region" with "Malaysia" selected. Below that is a "Birthday" section with three dropdown menus for month ("April"), day ("4"), and year ("2009"). A blue "NEXT" button is at the bottom, and a link "ALREADY HAVE AN ACCOUNT? SIGN IN" is below it.

Create account

Country, Territory, or Region

Malaysia

Birthday

April 4 2009

NEXT

ALREADY HAVE AN ACCOUNT? [SIGN IN](#)

If you are choosing to sign up with your email, you need to fill up your information.

TinkerCAD – Sign Up for an Account

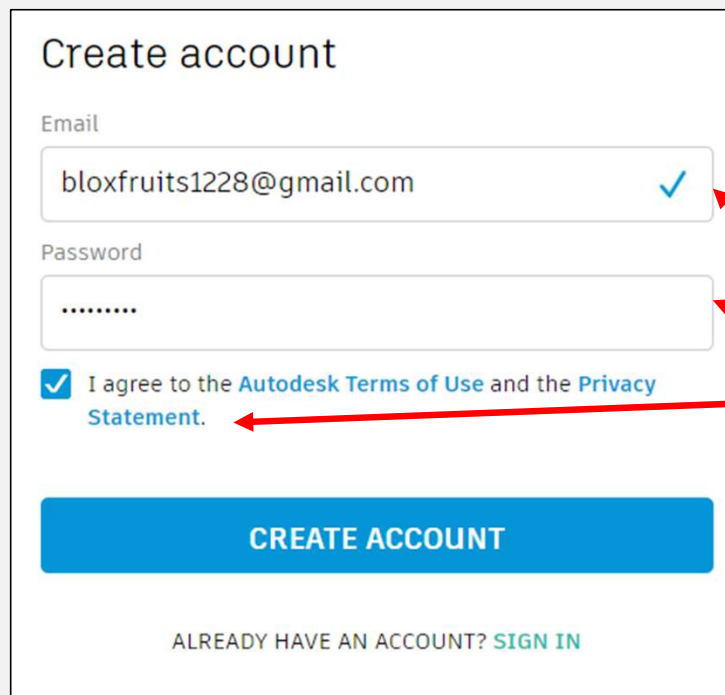
A screenshot of the TinkerCAD account creation form. The form is titled "Create account" and contains the following elements: an "Email" field with the text "bloxfruits1228@gmail.com" and a blue checkmark icon; a "Password" field with a masked password "....."; a checkbox that is checked, with the text "I agree to the Autodesk Terms of Use and the Privacy Statement."; a large blue button labeled "CREATE ACCOUNT"; and a link at the bottom that says "ALREADY HAVE AN ACCOUNT? SIGN IN". Three red arrows point from the text box on the right to the checkmark in the email field, the masked password field, and the checked checkbox.

Then you can fill in your email and password.

Please be aware that the email stored in their database is unique, so if the email is already registered before, it won't show a tick here.

So please make sure your email is valid (it will show a tick like this).

Then you need to check the box to agree with the Terms of use and privacy statement before you continue.

TinkerCAD – Verify your Email

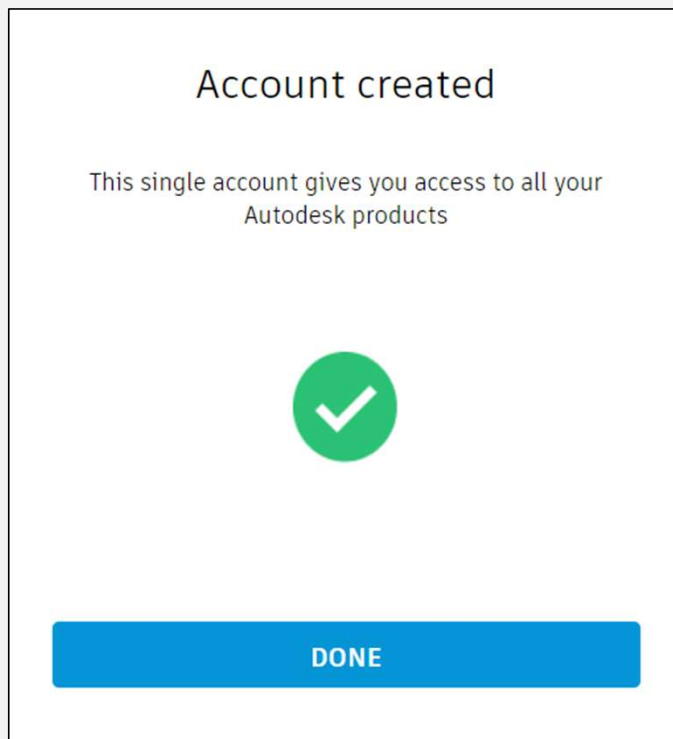

This means the account is successfully created.

Don't forget to check the inbox in your email that you registered with, there is a verification email to verify your account before you can begin using your Autodesk Account.

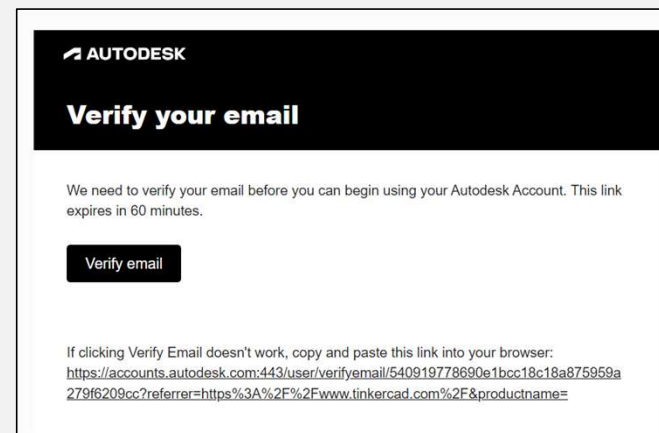

TinkerCAD – Create your first 3D design

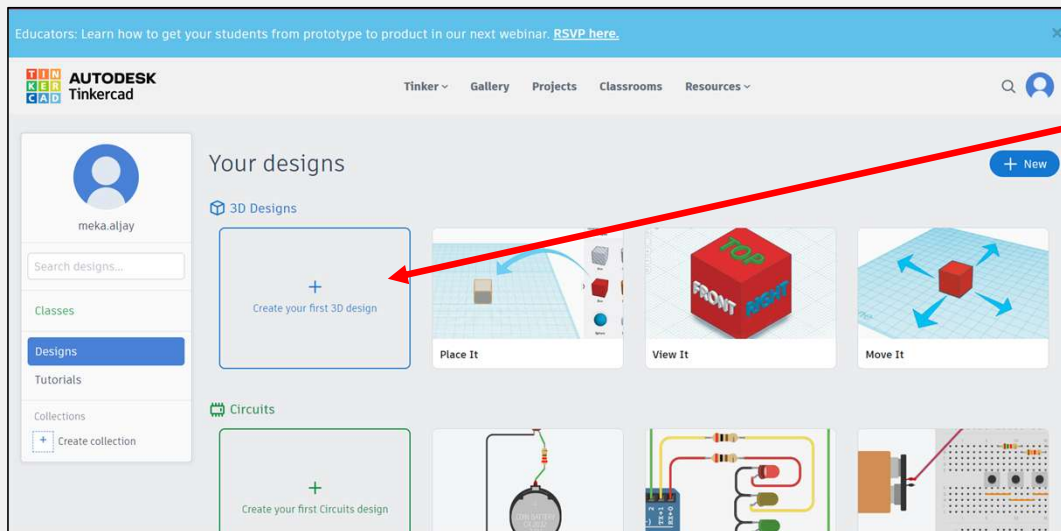

On the first page of your TinkerCAD, you can click here to begin your new project.

TinkerCAD - Create your first 3D design

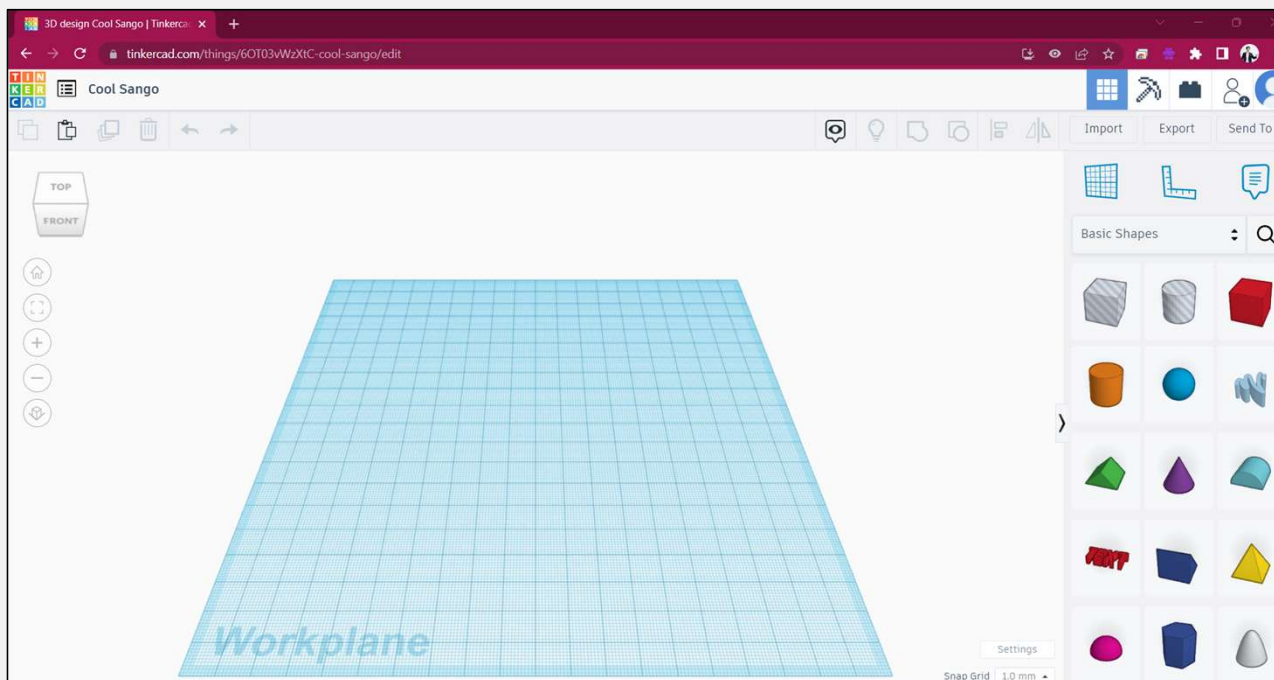

And this is the user interface of TinkerCAD.

The middle one with blue grids is call "Workplane", which is the plane for you to design your 3D item.

TinkerCAD - User Interface

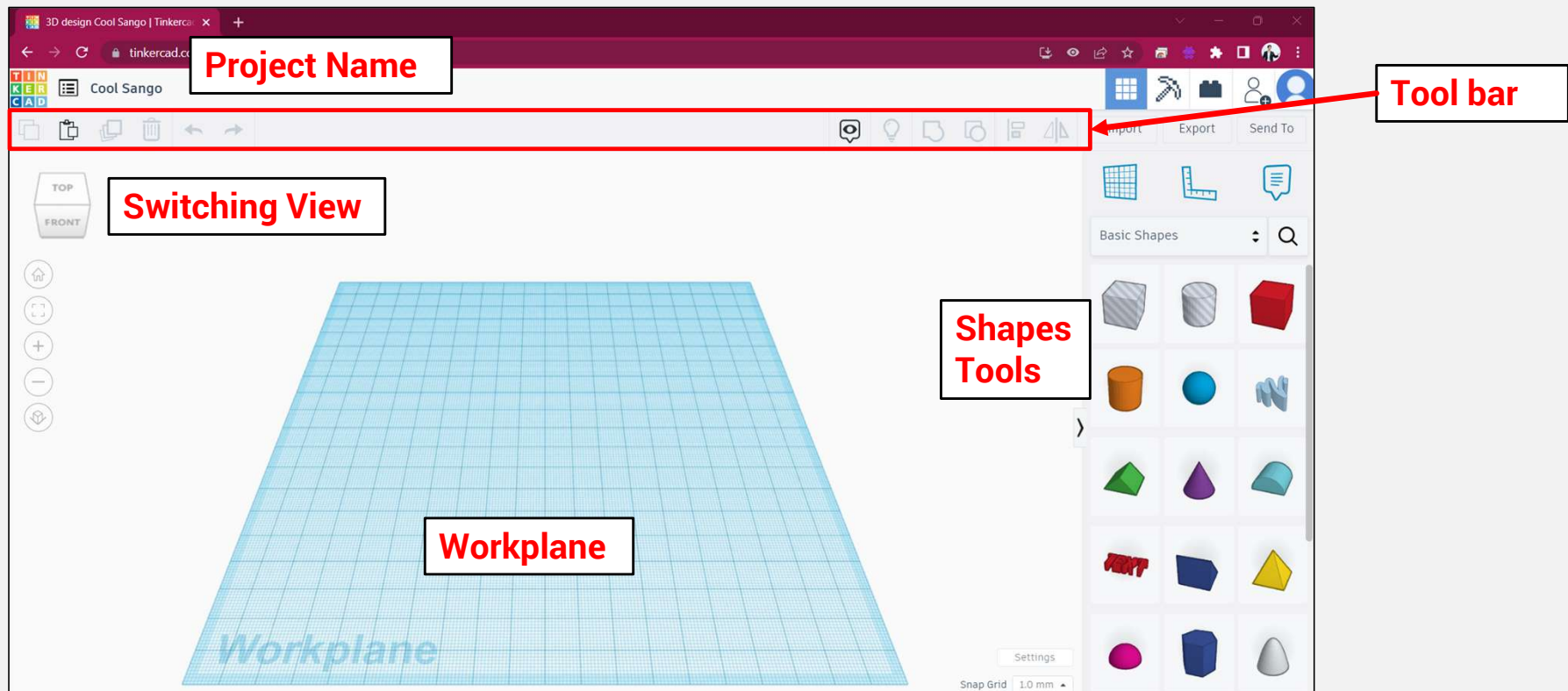

TinkerCAD - Add a Cube

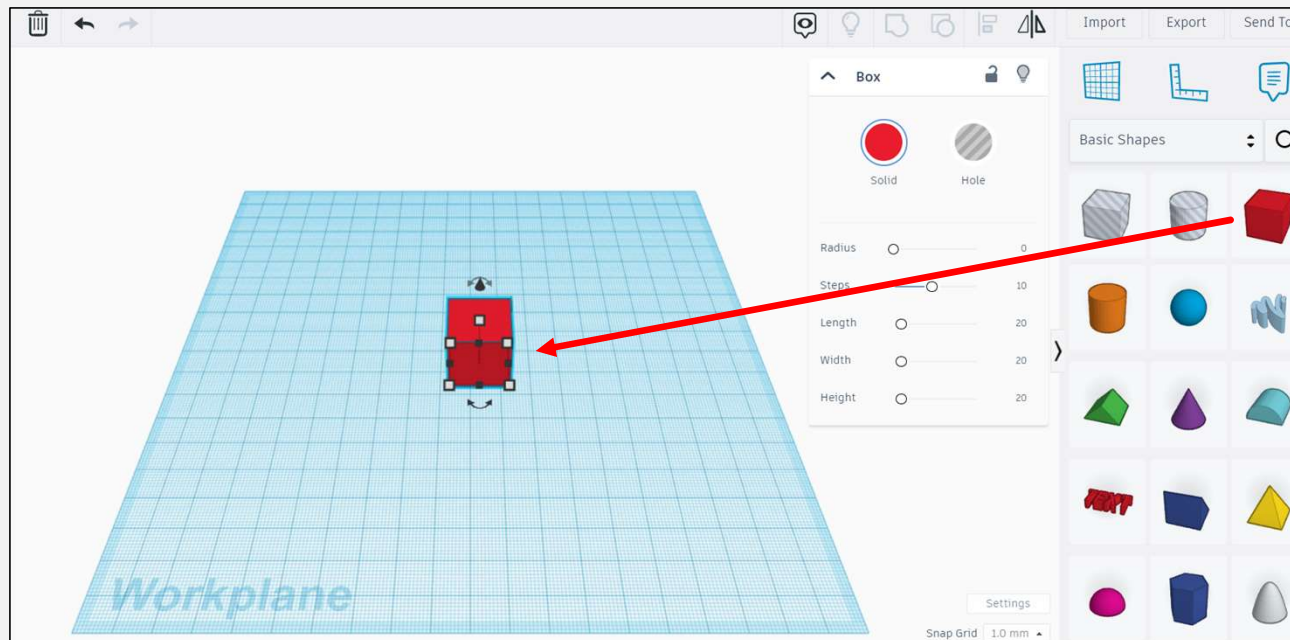

You can drag a cube from the basic shapes to the workplane.

TinkerCAD - Add a Cube

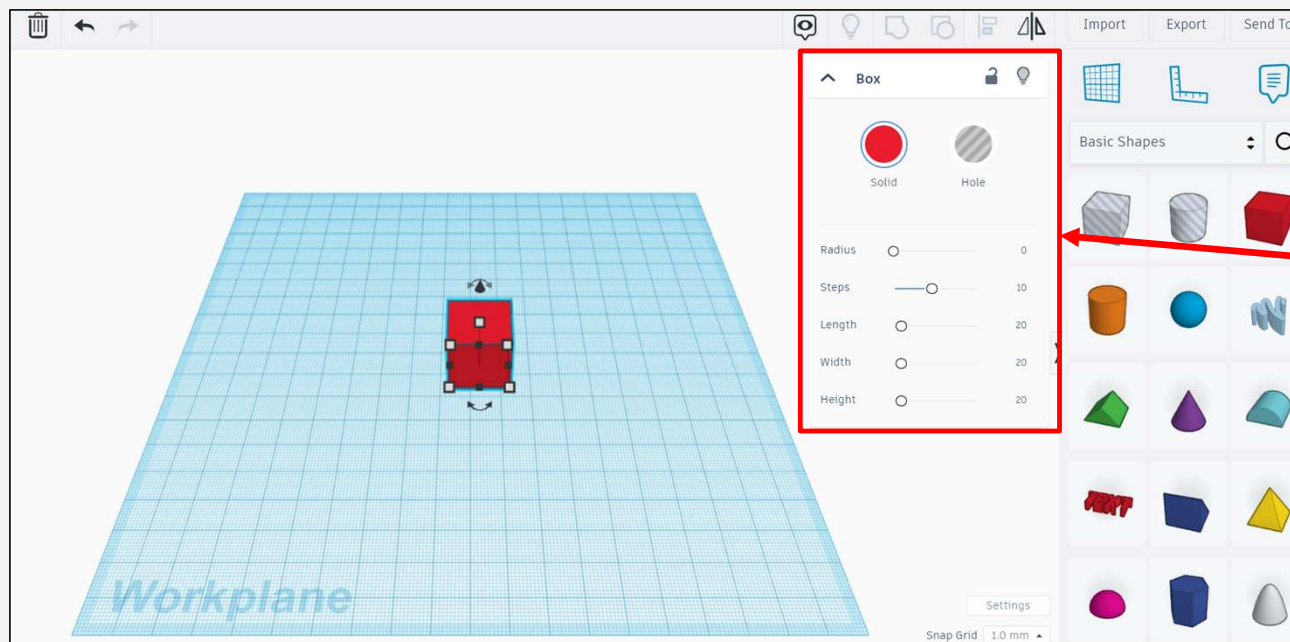

When the cube is selected, the properties box will pop out and allow you to change the properties of the shape.

TinkerCAD - Perspective

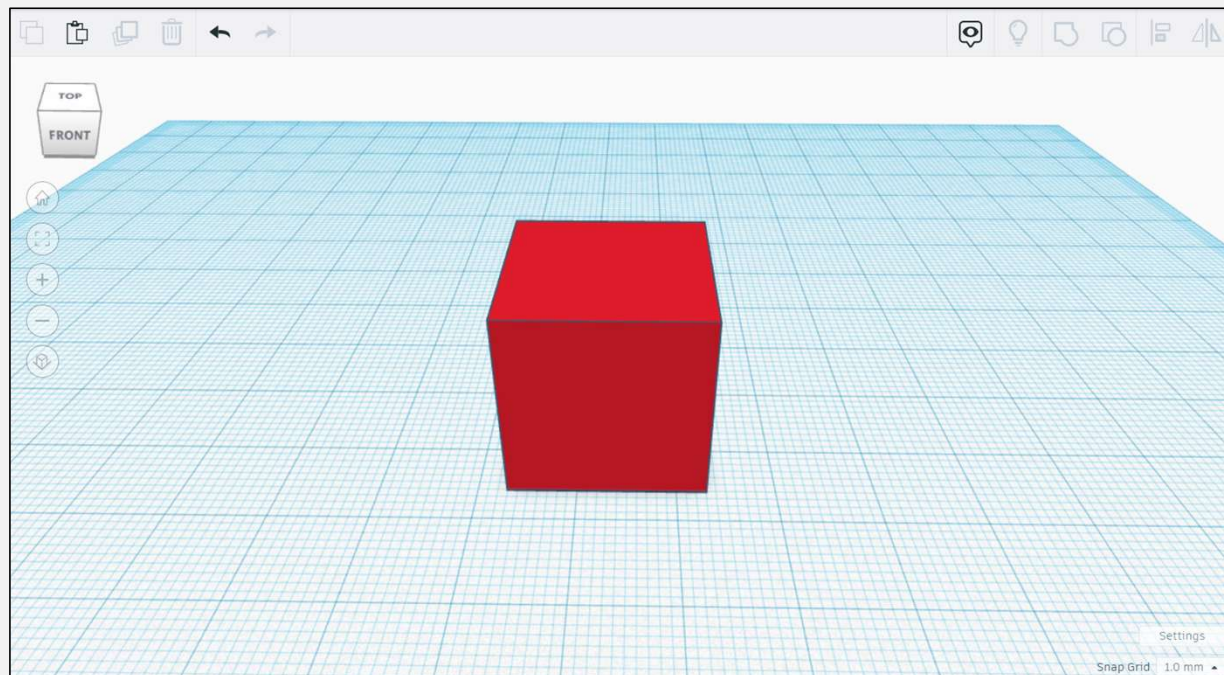

Scrolling:
Zoom in & Out

Hold down Scroll wheel:
Panning

Left Click:
Select

Hold down Right Click:
Rotate the view



TinkerCAD - Perspective

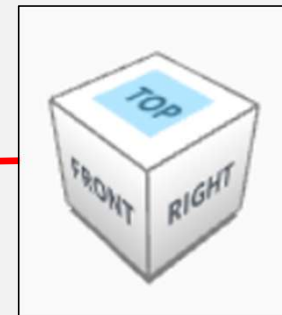
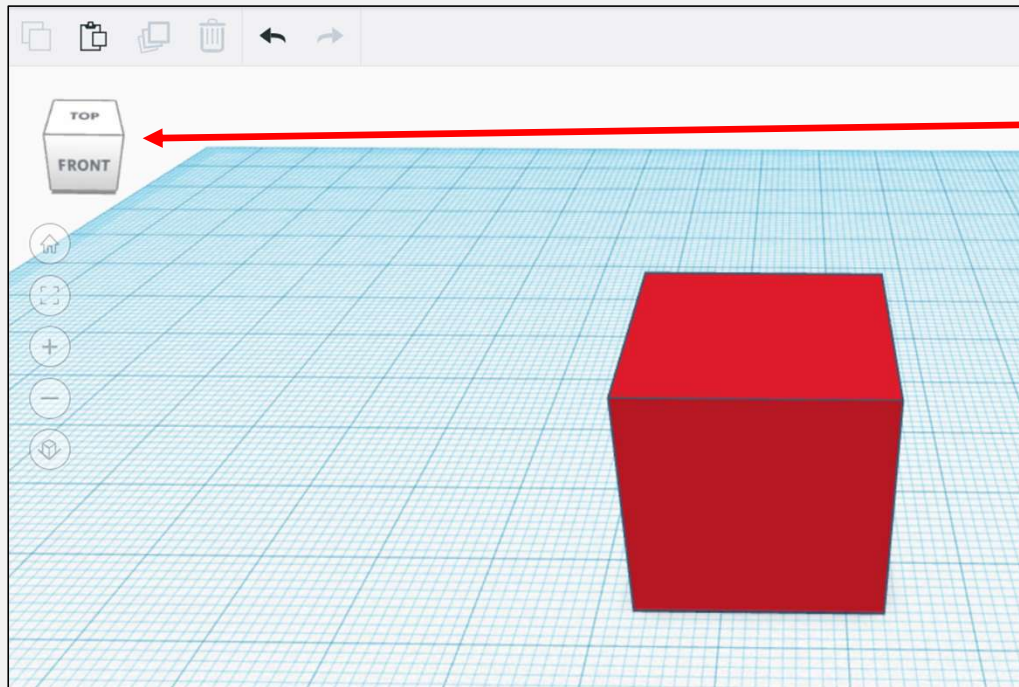

If you want to change the view directly to “Top” / “Front” / “Right” / “Left” / “Back” / “Bottom”, you can also click on the cube of the top right corner, it will help to switch the view to your selection.

TinkerCAD - Dimension Checking

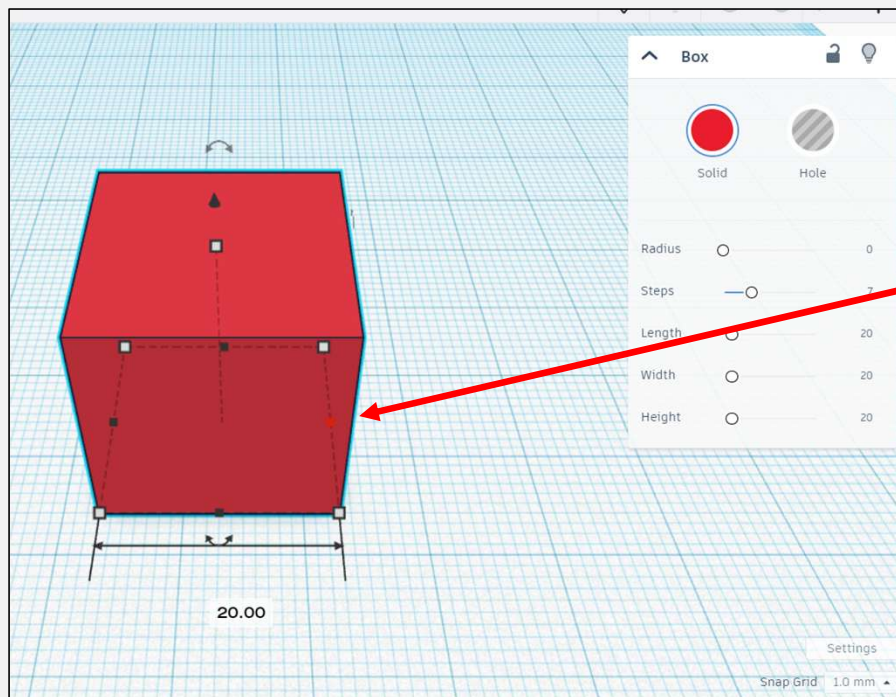

When the cube is selected, you can see that there are few black points to click on.

If you click on any of the black points, it will show you the dimension of the side, (20.00 in this case), this is with the unit of mm (millimeter).

TinkerCAD - Dimension Checking

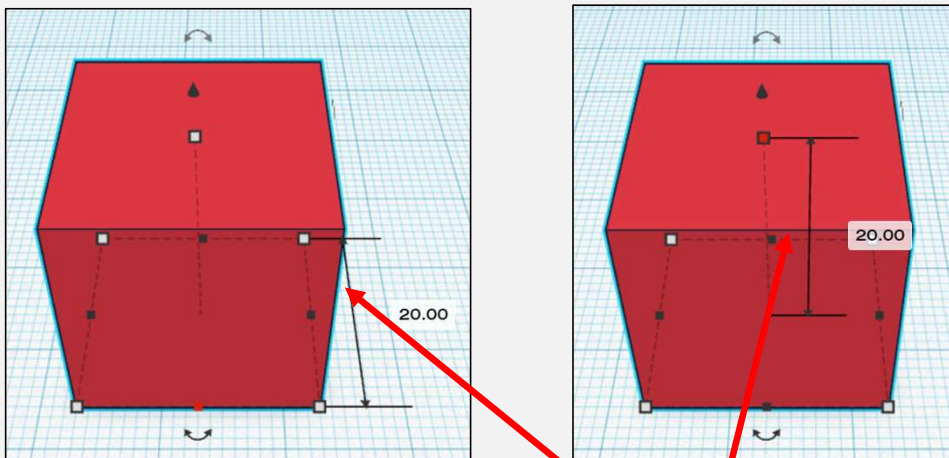

If you click on different sides, you will know that this is a cube with 20mm each side (height, width, length), when this design is printed out, it will be a 2cm x 2cm x 2cm cube.

TinkerCAD - Manipulate the size

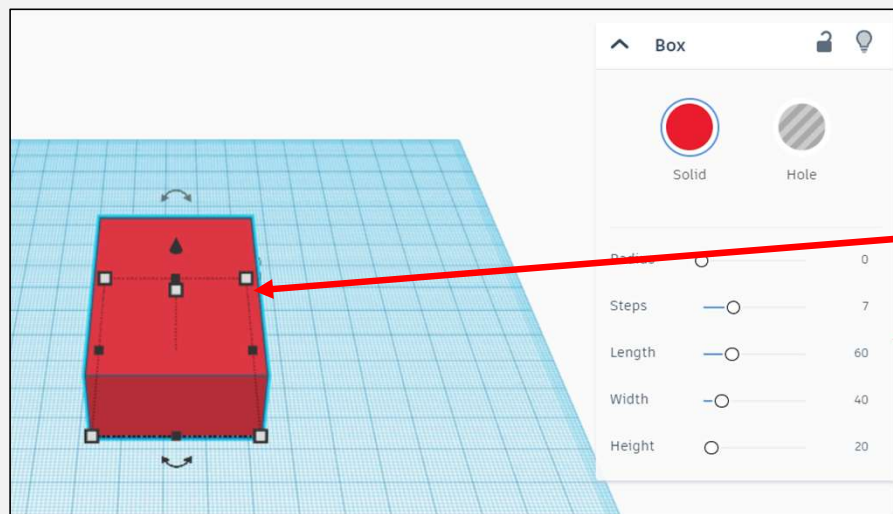

You can either change the dimension from the properties box of the cube, or drag and pull the points from the cube to stretch the cube.

TinkerCAD – Solid Cube

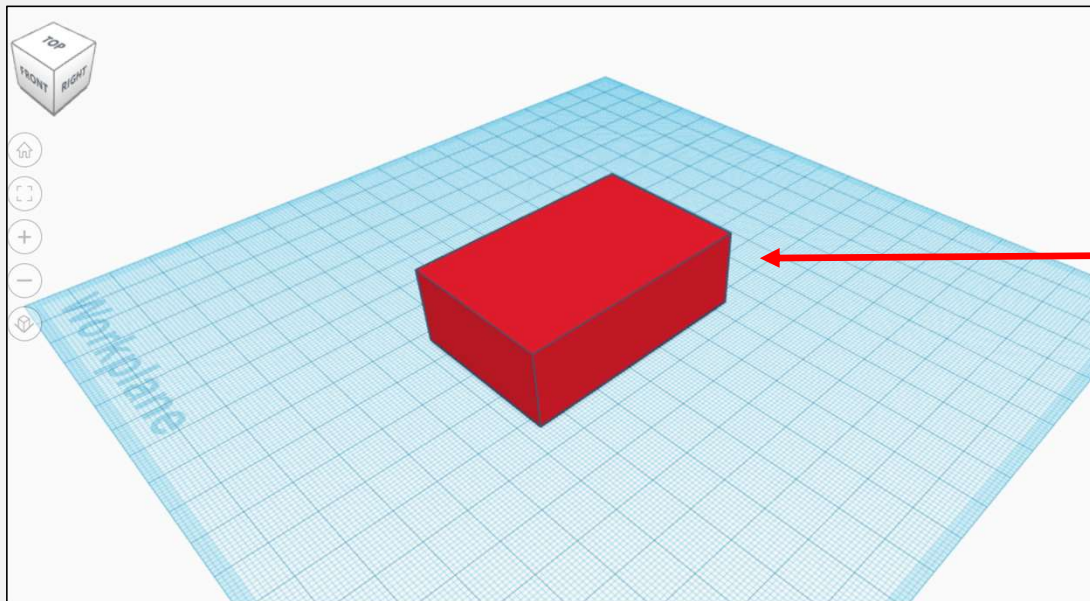

This is a solid cuboid that we make, if we just print this out, the 3D printing material is going to fill all filament in this cuboid.

Let's say if I want to make the cuboid inside empty or make it like a container, we need to remove the material inside and keep a certain thickness for the cuboid, how should I do it?

TinkerCAD – Solid Cube

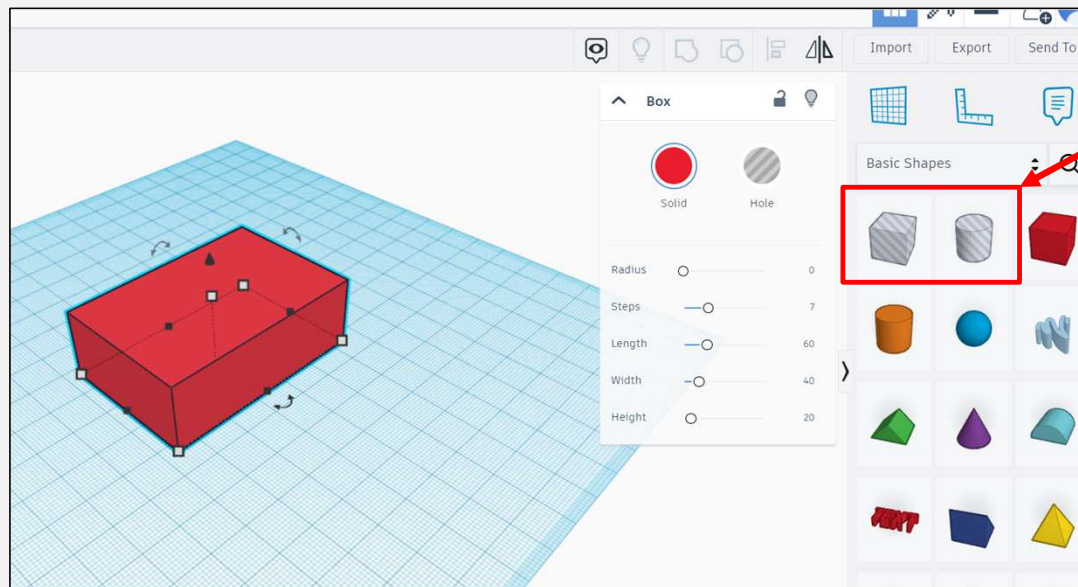

Notice that there are 2 shapes that are grey color with stripe, these are the shapes that can help to offset (cut off) the material.

These are called hole shape, with the purpose of cutting off some materials from our shapes.

TinkerCAD - Container

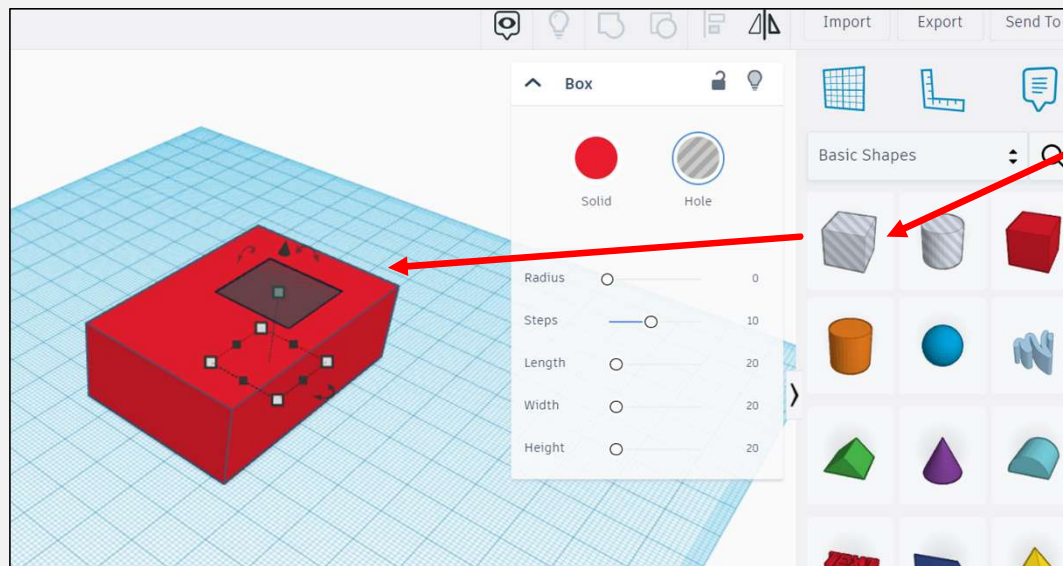

Let's drag a cube hole and put it in our cuboid.

TinkerCAD - Container

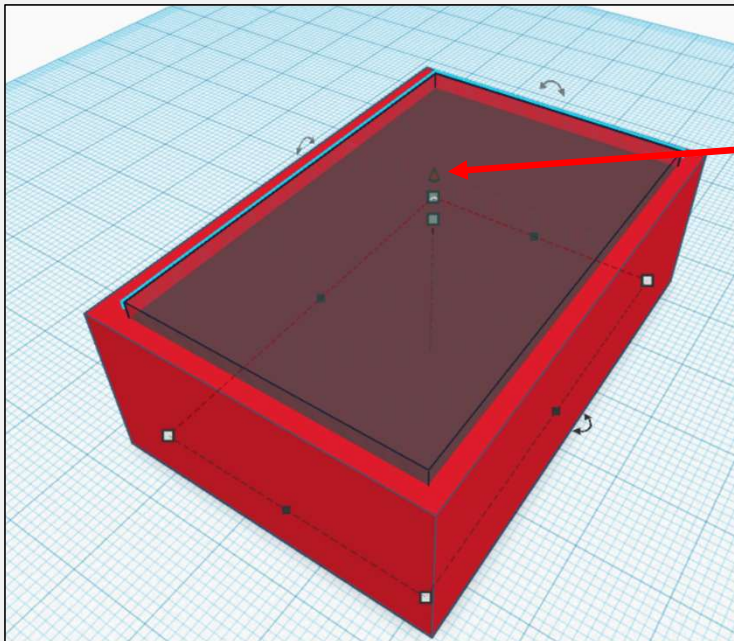

Stretch the cuboid hole (grey color) and make it just a bit smaller than our cuboid. And also pull it upward a bit to make sure it doesn't remove our bottom.

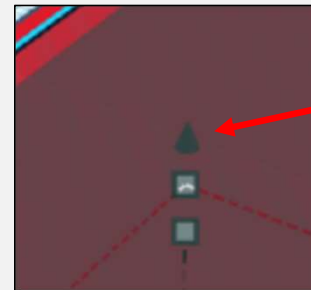

If you want to just pull up the cuboid hole, you can drag the arrow pointing upward, this will only change the Y-axis for the cuboid hole.

TinkerCAD - Container Dimension

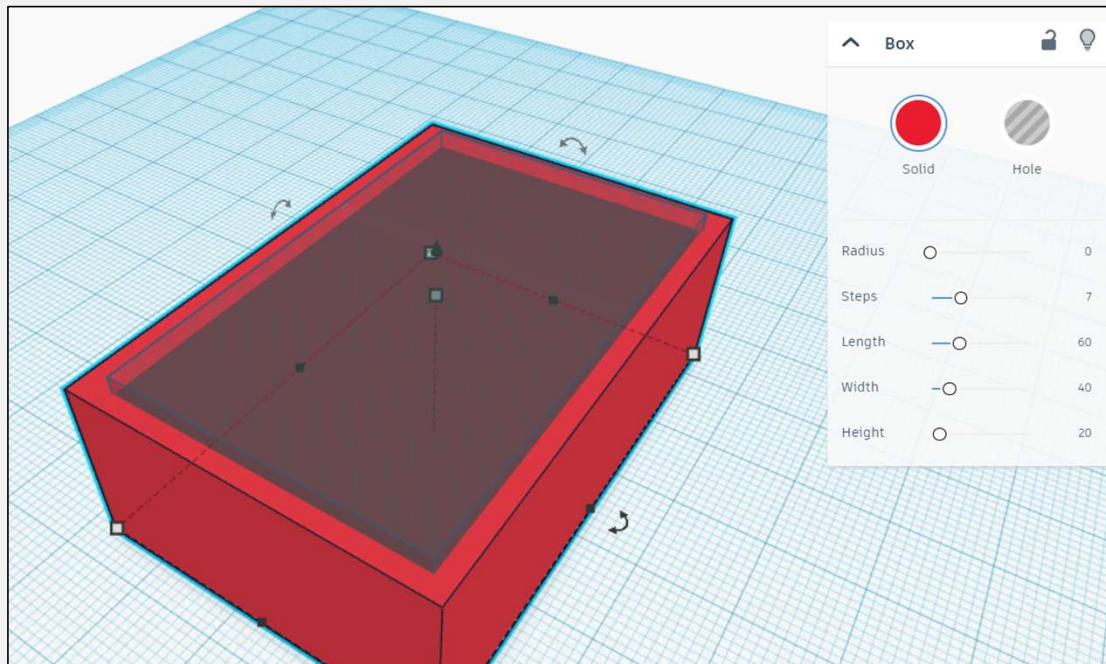

How to check our cuboid dimension?

Select the cuboid (red color) and check the properties box.

In my case, my cuboid is with these dimensions:

- Length -> 60mm**
- Width -> 40mm**
- Height -> 20mm**

TinkerCAD - Remove the middle part

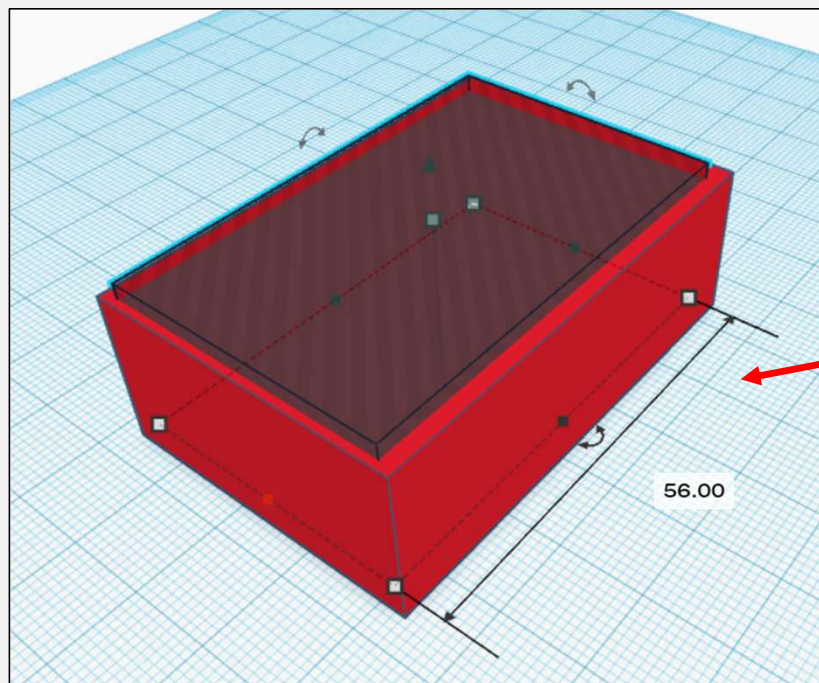

Now our goal is to make a container with thickness of 2mm.

So, for length, we need to **remove 60mm – 4mm = 56mm materials** and **keep each side 2mm** for the red cuboid

To do this, you can drag the black point at the side and pull until the dimension become **56.00 mm**.

TinkerCAD - Remove the middle part

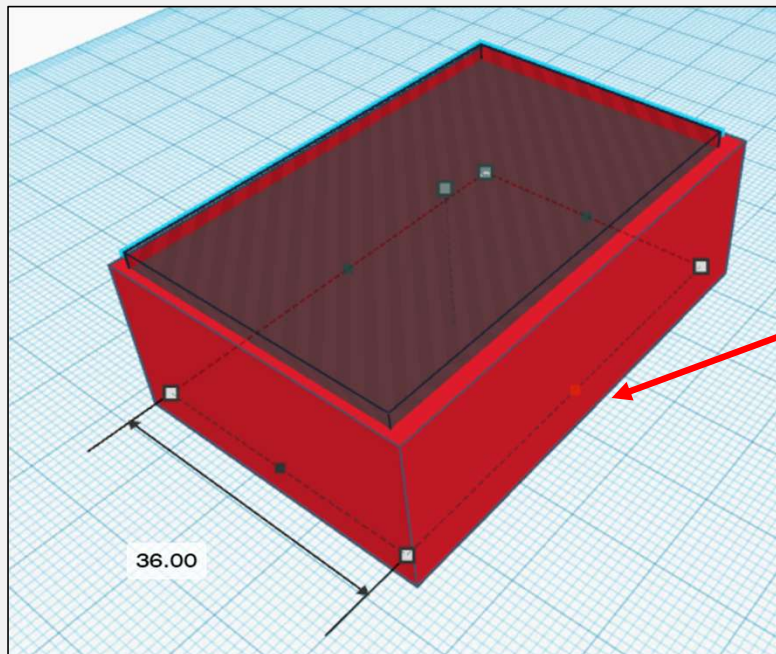

For width, we need to **remove 40mm – 4mm = 36mm materials** and **keep each side 2mm** for the red cuboid

To do this, you can drag the black point at the side and pull until the dimension become **36.00 mm**.

TinkerCAD - Remove the middle part

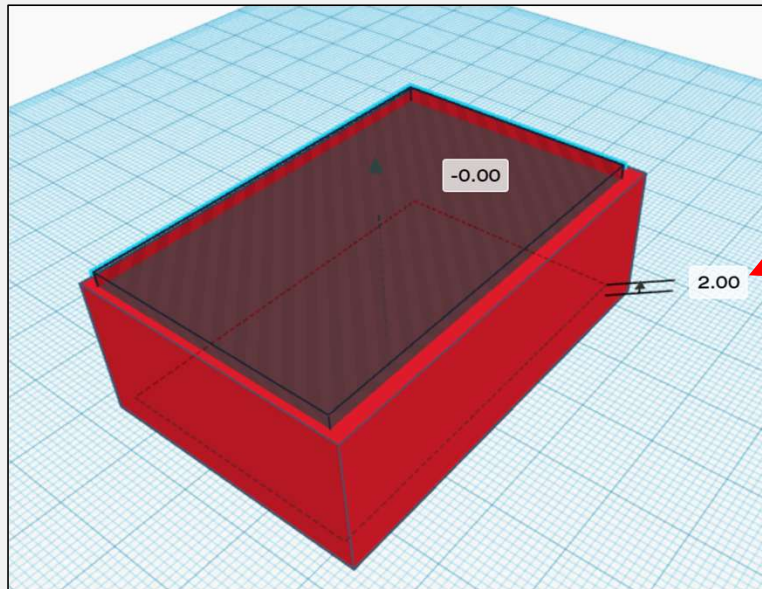

For height, we will just need to pull out the grey cuboid 2.00 mm away from bottom, to keep the bottom part with **2.00mm thickness**.

TinkerCAD - Remove the middle part

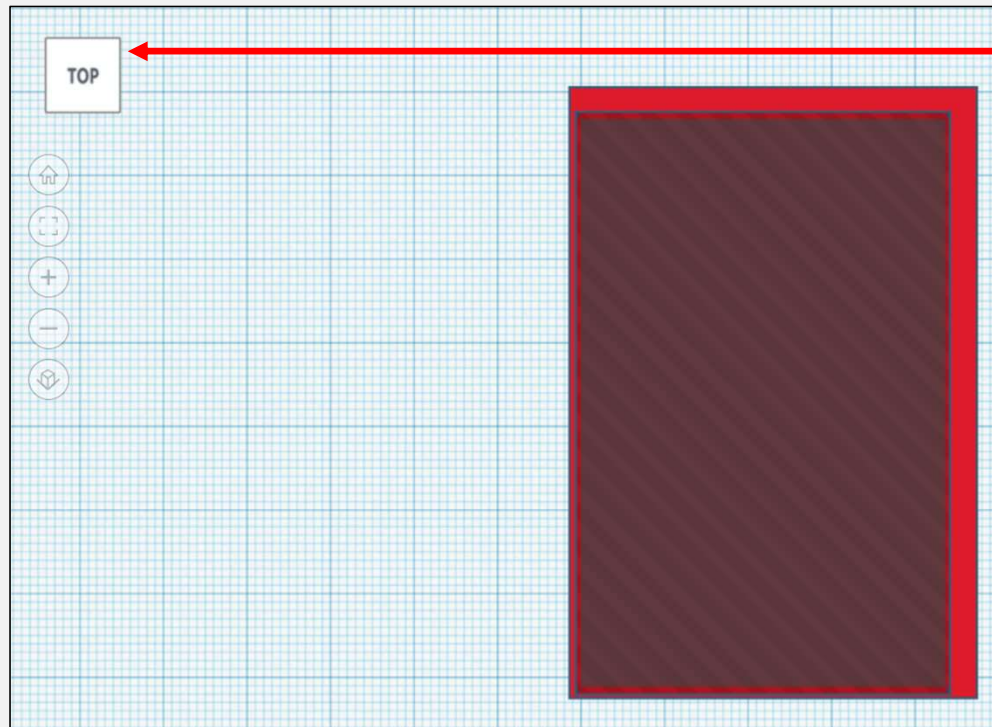

When switching back to the top view, I can see that hole is not at the center of the container, it's misaligned.

If we print out the part like this, the 2 sides of our container will be thicker than other sides.

So to make it align to center, we can use the alignment tool.

TinkerCAD - Multiple Selection

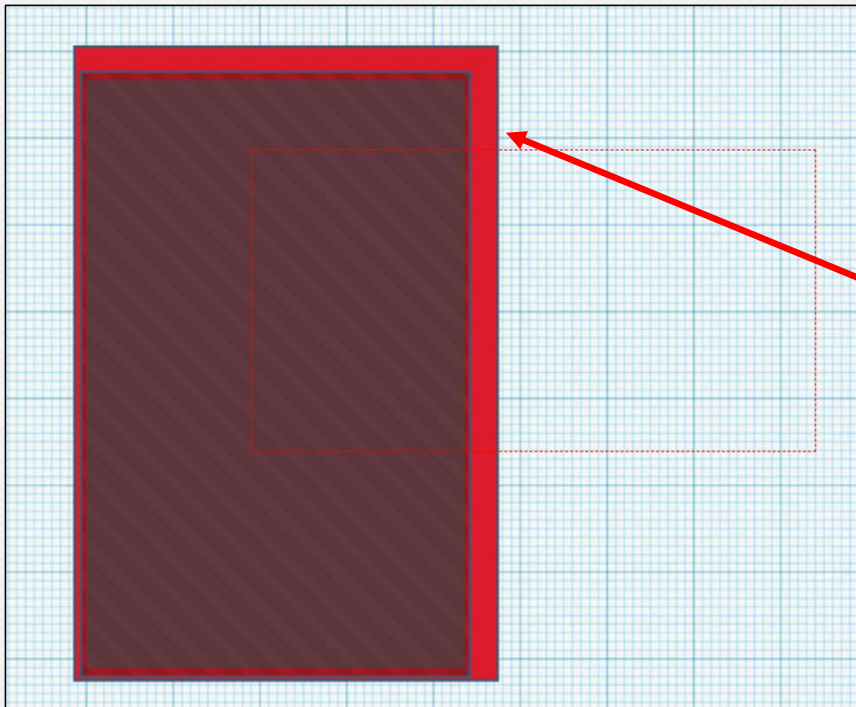

Before we do alignment, we need to select multiple parts (the red and grey cuboids), so that they know which parts to align with.

Multi-selection methods can be either holding down the "Shift" key and click on the first part, then click on another part.

Or you can just use your mouse to click and drag over the 2 parts.

TinkerCAD - Multiple Selection

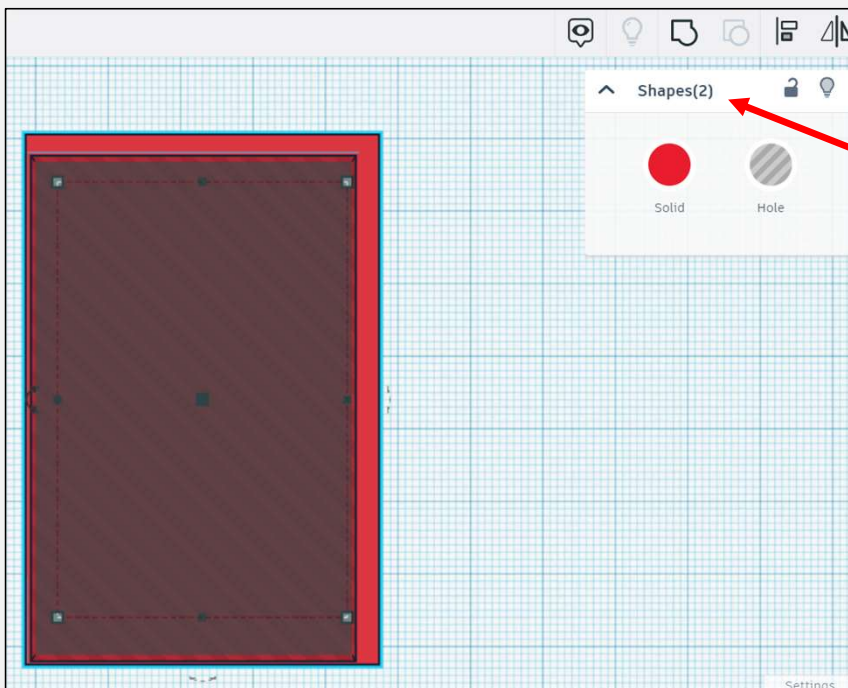

How to know if your parts are selected at the same time?

You can check your properties box at the right, the title will change to Shapes(2), the meaning of "2" inside the parenthesis refer to how many parts are being selected at once.

TinkerCAD - Alignment

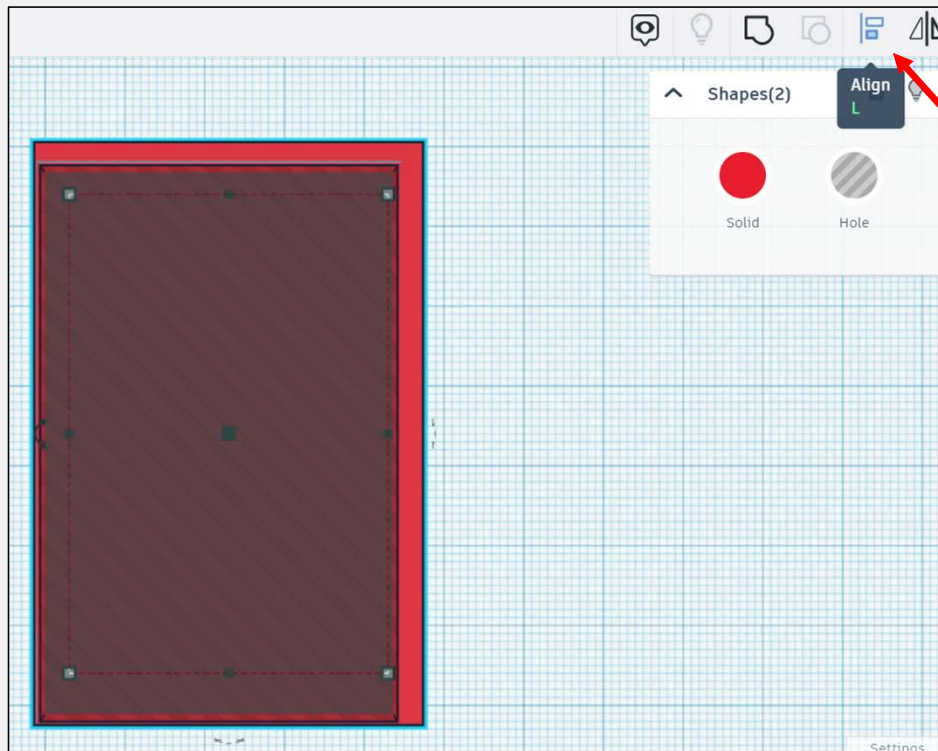

There's a tool here called "Align" when you hover your mouse over.

This is to align the selected parts.

If only 1 part is selected, the align tool will be disabled.

So make sure you selected multiple parts before you can use the align tool.

TinkerCAD - Alignment

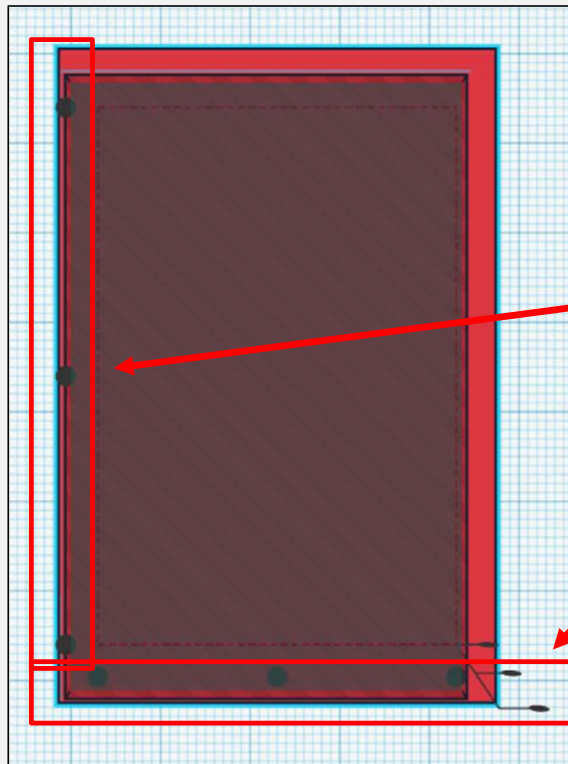

Once you click the Align tool, you will see fill big and round black points on each side (each side has 3 points, left, middle and right).

TinkerCAD - Alignment

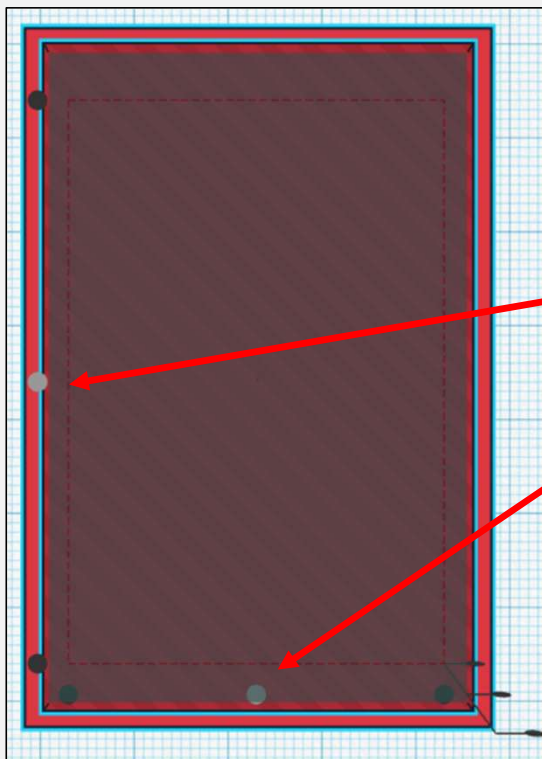

By clicking the black points, it will auto-align both to the center.

We do not need to align the height, because we already move the grey cuboid 2.00mm away from the bottom to keep the bottom's thickness.

TinkerCAD - Alignment

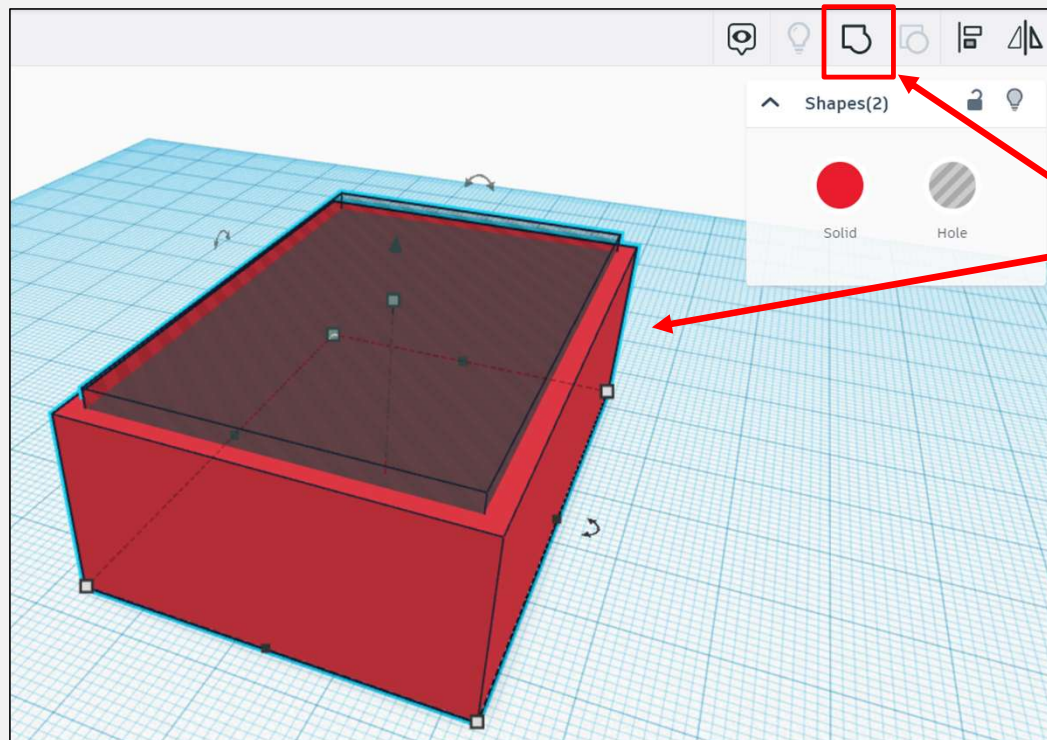

Now I will rotate the view like shown at left.

Make sure the 2 parts still being selected, then we need to combine them together by using the group tool.

TinkerCAD - Container

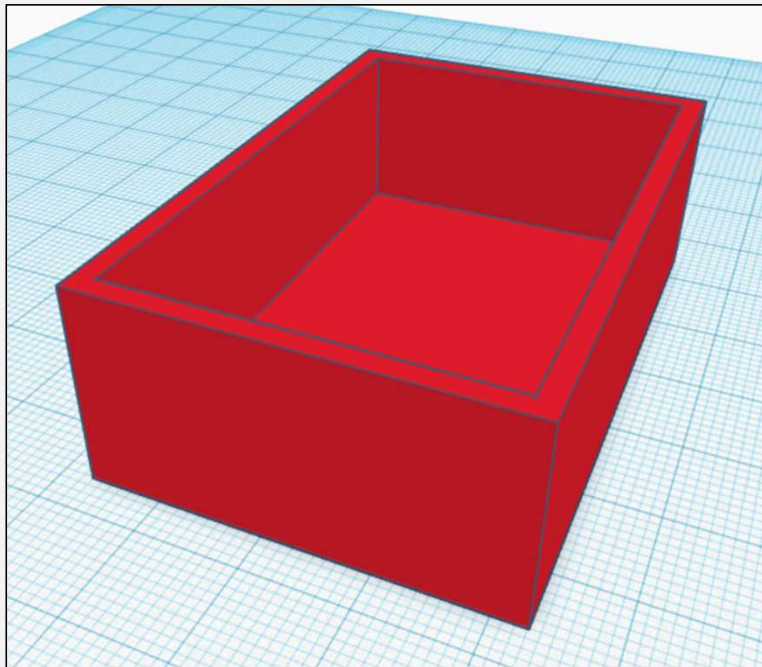

Now we have done our Container.

TinkerCAD - Add a text

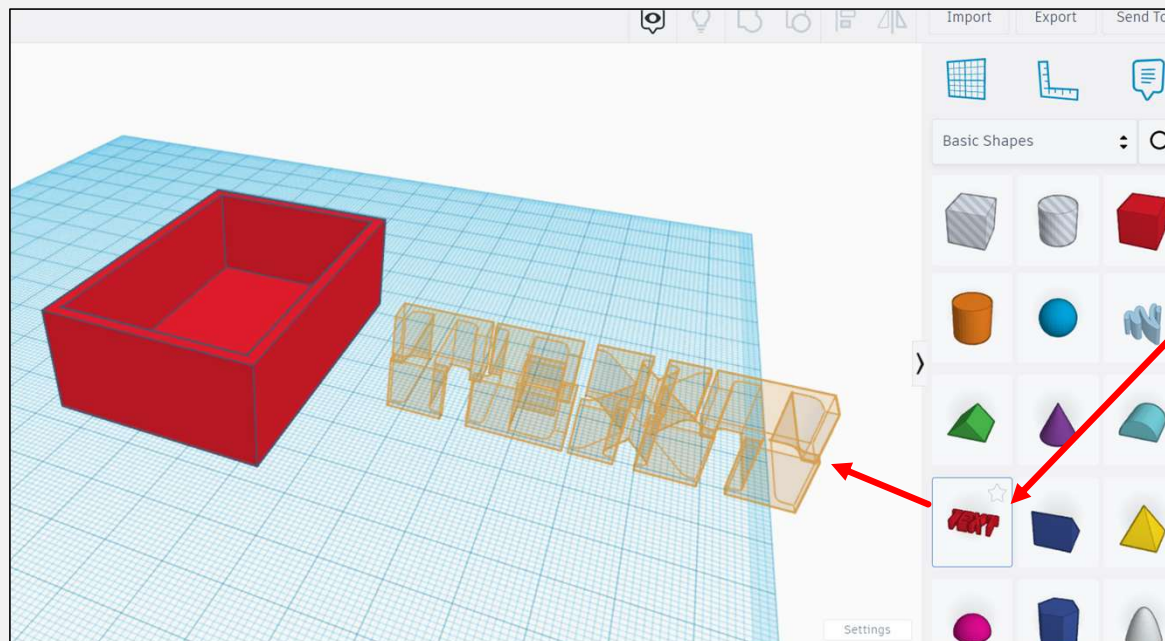

There's a text shape in the basic shapes, you can drag the text shape to the workplane.

TinkerCAD - Add a text

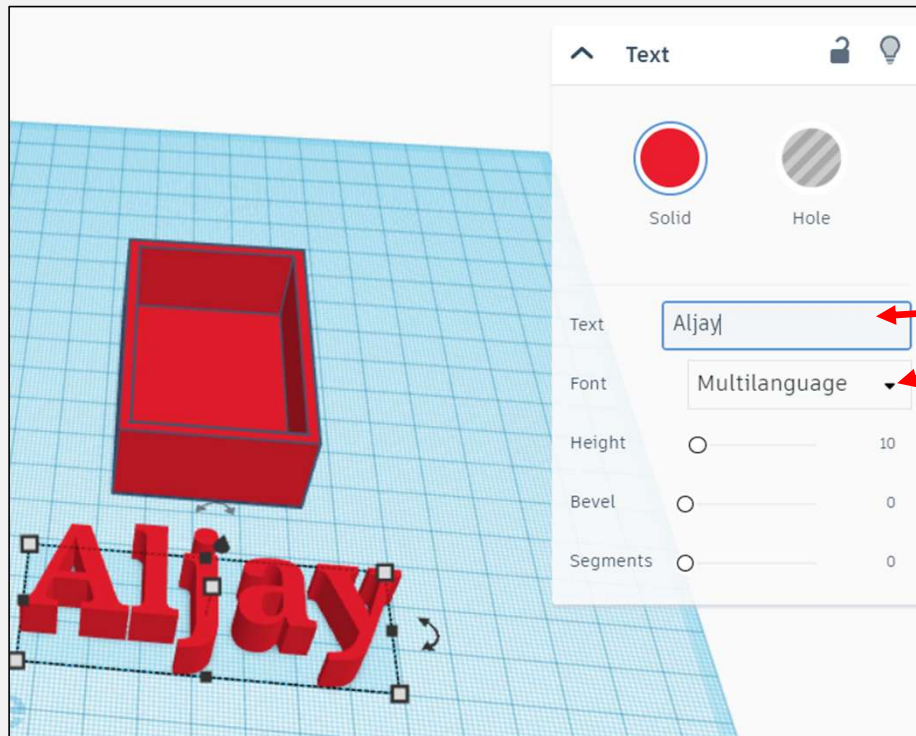

You can rename the Text and select the font you like.

TinkerCAD - Add a text

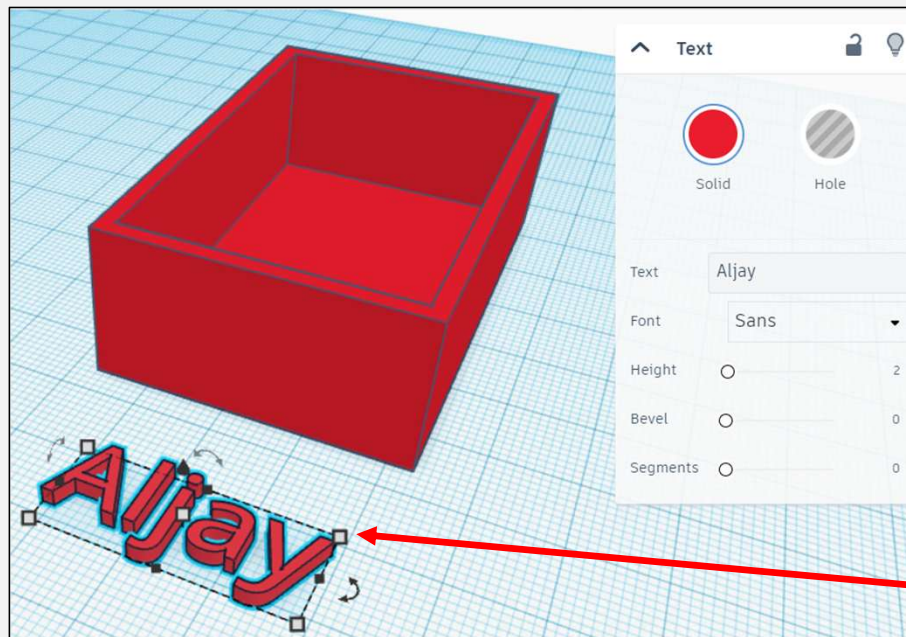

Let's set the height (height also means thickness of the text) to 2.00mm.

Scale down your text by dragging the white points at the corners.

TinkerCAD - Add a text

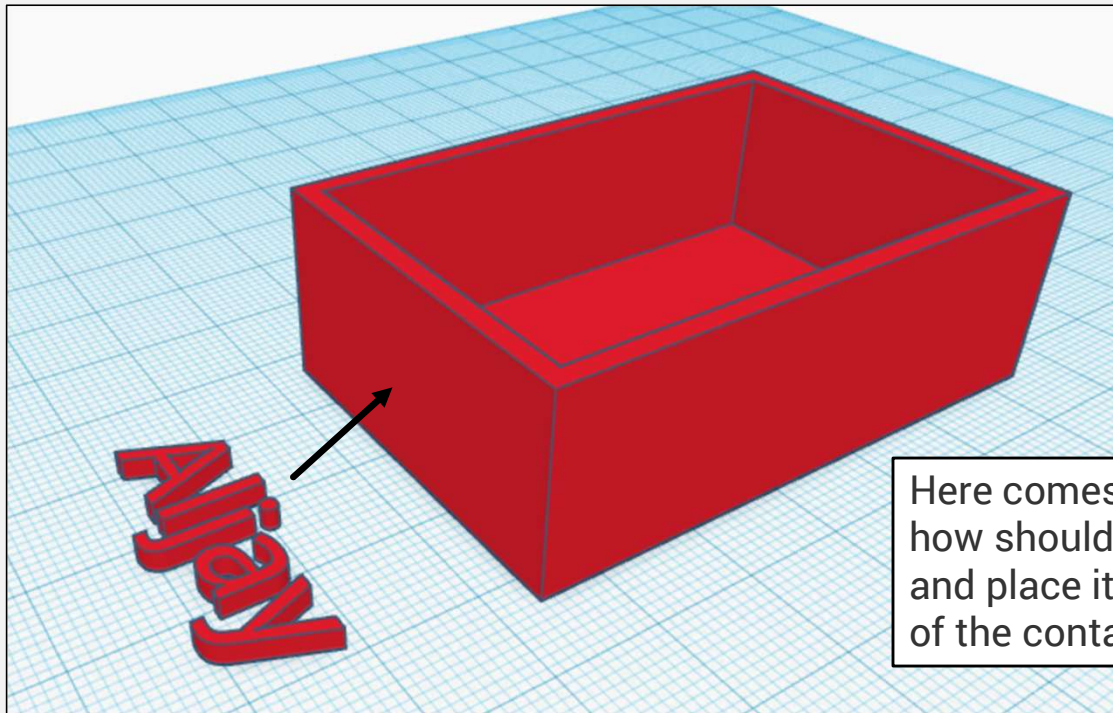

Here comes a problem,
how should I rotate it
and place it on the side
of the container?

TinkerCAD - Rotate

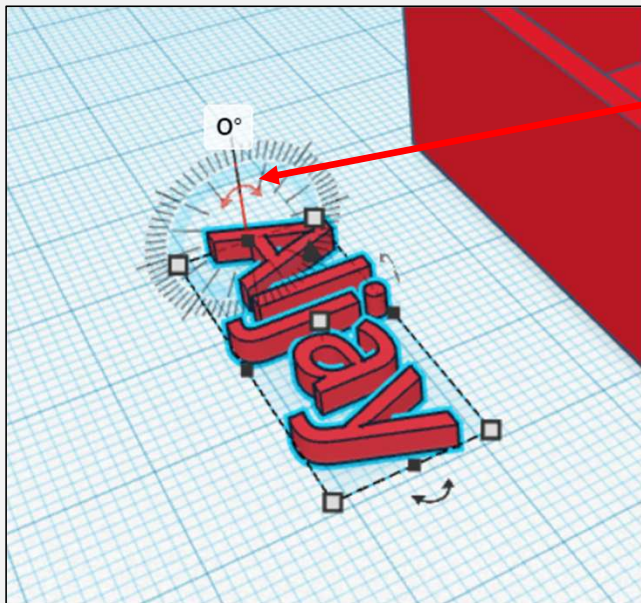

There is a rotate icon  at the side when the text is selected.

Click this and change the number of the degree to 90° to rotate the text and make it face to front.

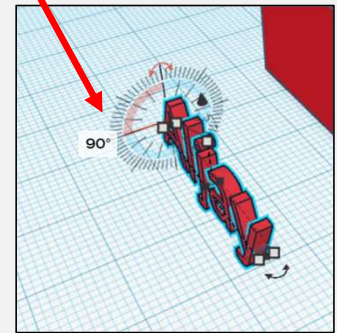

TinkerCAD - Stick to the container

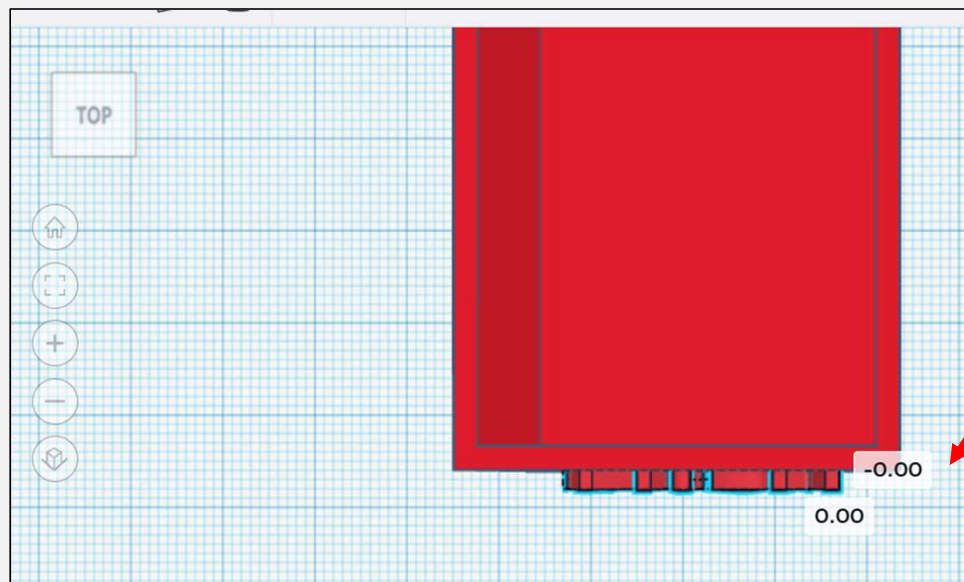

Now we switch back to the top view, and attach the text to the container, make sure there's 0.00 distance between the text and the container.

TinkerCAD - Stick to the container

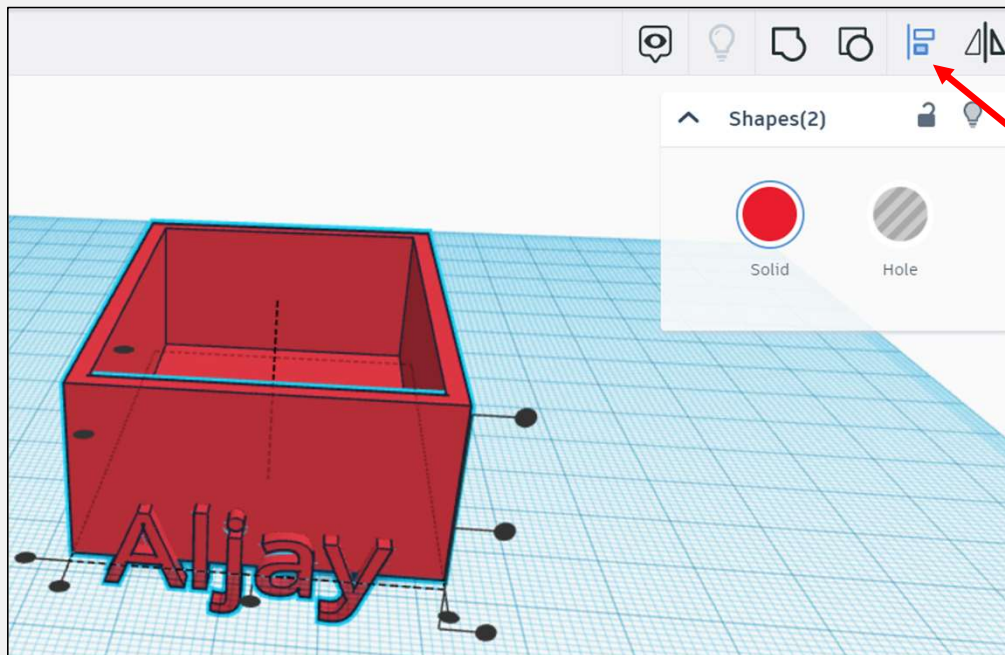

Now align the name to the container by using the align tool (make sure both text and the container are selected).

TinkerCAD - Stick to the container

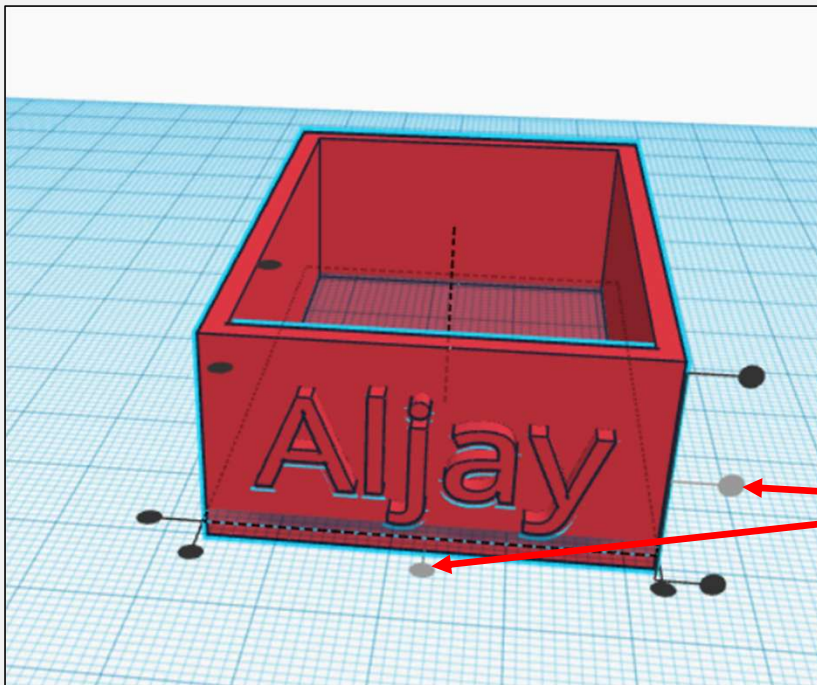

I will align my name at the center of the container.

TinkerCAD - Group

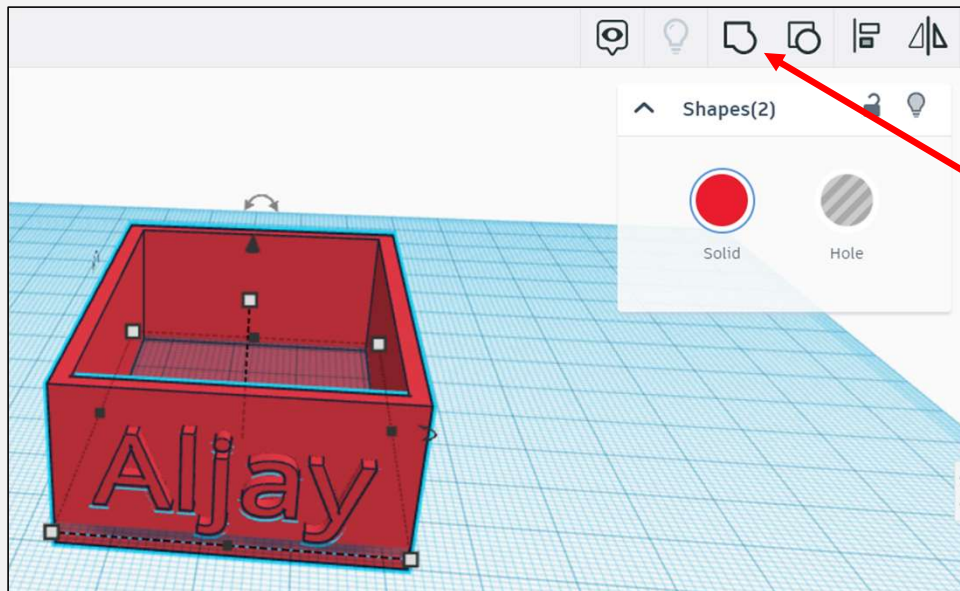

Remember to group them to make the text stick to the container.

TinkerCAD - Completed

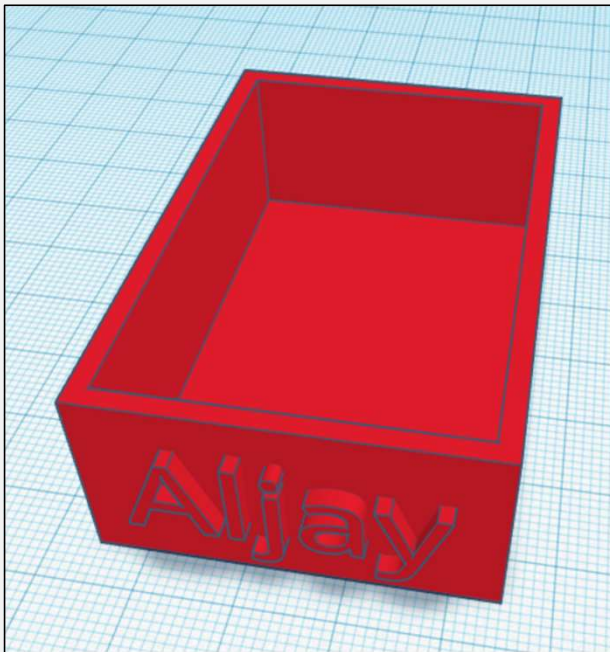

Now your container is completed.

TinkerCAD - Export to STL

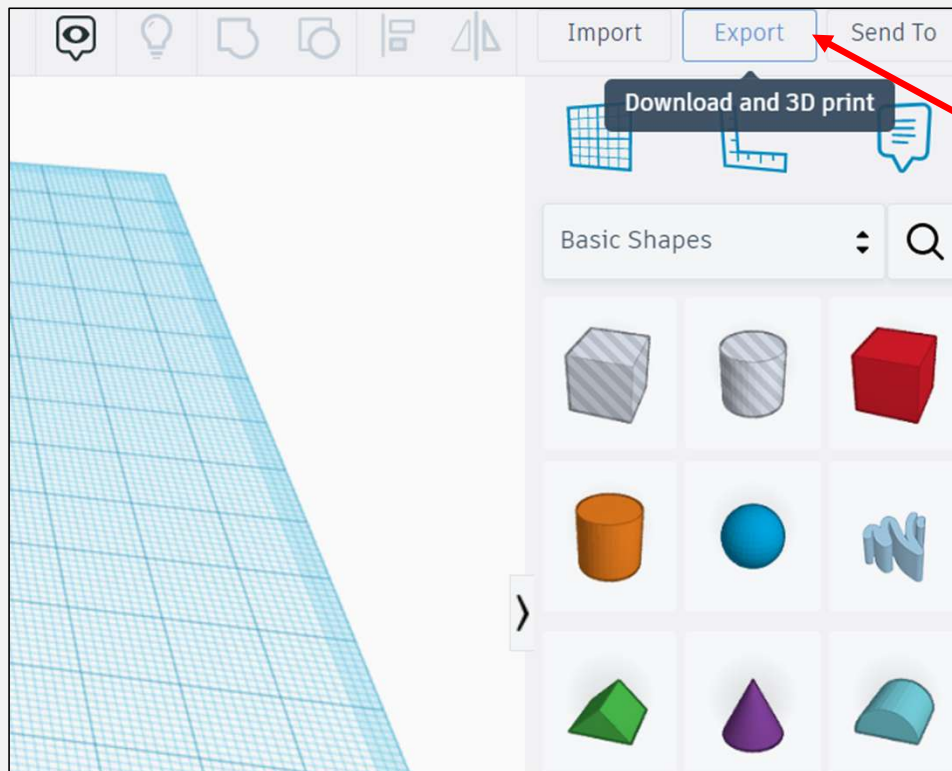

First step to export for 3D printing is clicking this to export into .stl file format.

TinkerCAD - Export to STL

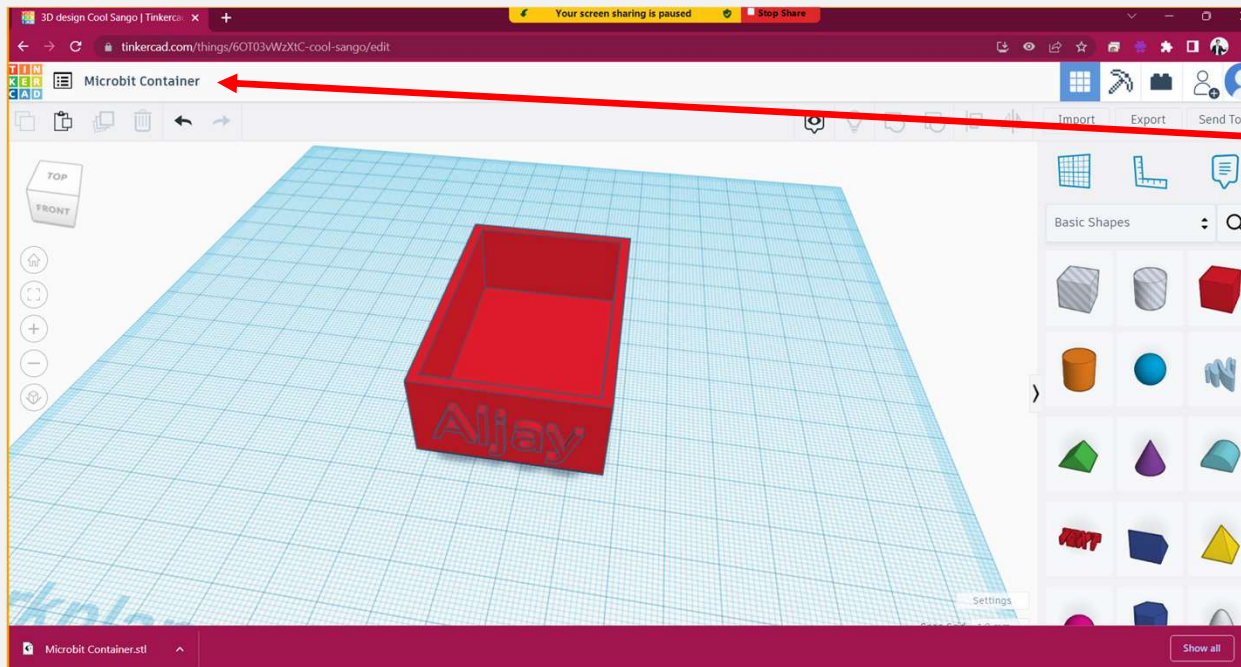

You can rename your project properly, so in future if you would like to change the design, it's easily found back and redesign it.

3D Printer – FlashForge Adventurer 3



Adventurer 3

Adventurer3 is the best choice for family, school, workshop, and 3D printing beginners. The friendly interface design and easy-to-use powerful functions make 3D printing easy.

The 3D printer to be used is called FlashForge Adventurer 3.

So before we start printing, we need to convert the stl file to gx code and import into the 3D printer.

3D Printer – FlashForge Adventurer 3

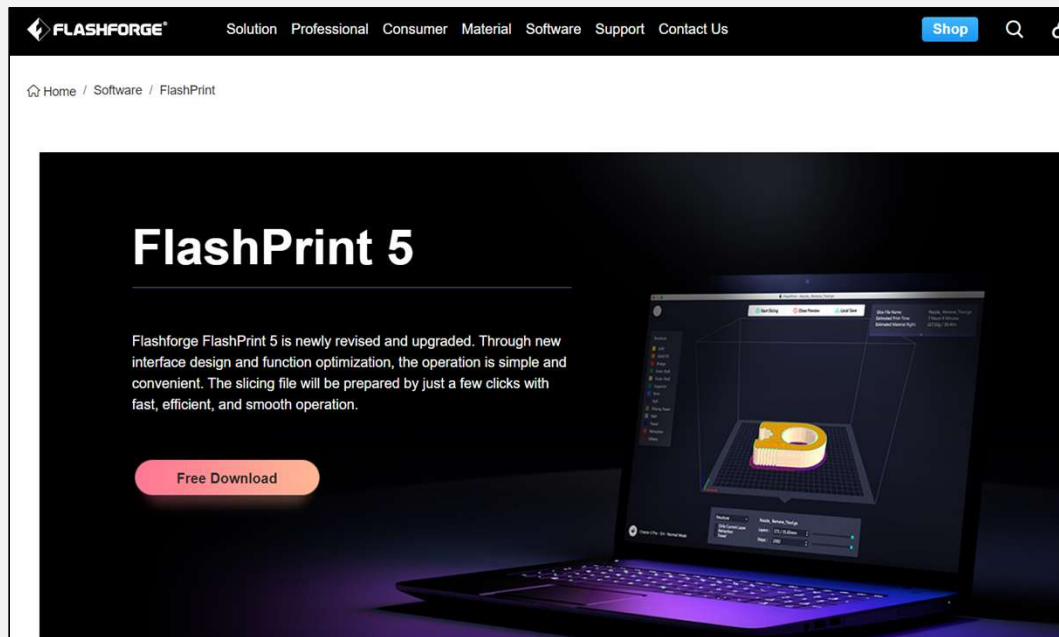

Let's go to download the FlashPrint 5 App to do setting for our model.

Install the App after downloading to your laptop.

<https://www.flashforge.com/product-detail/FlashPrint-slicer-for-flashforge-fdm-3d-printers>

3D Printer – FlashPrint 5 App

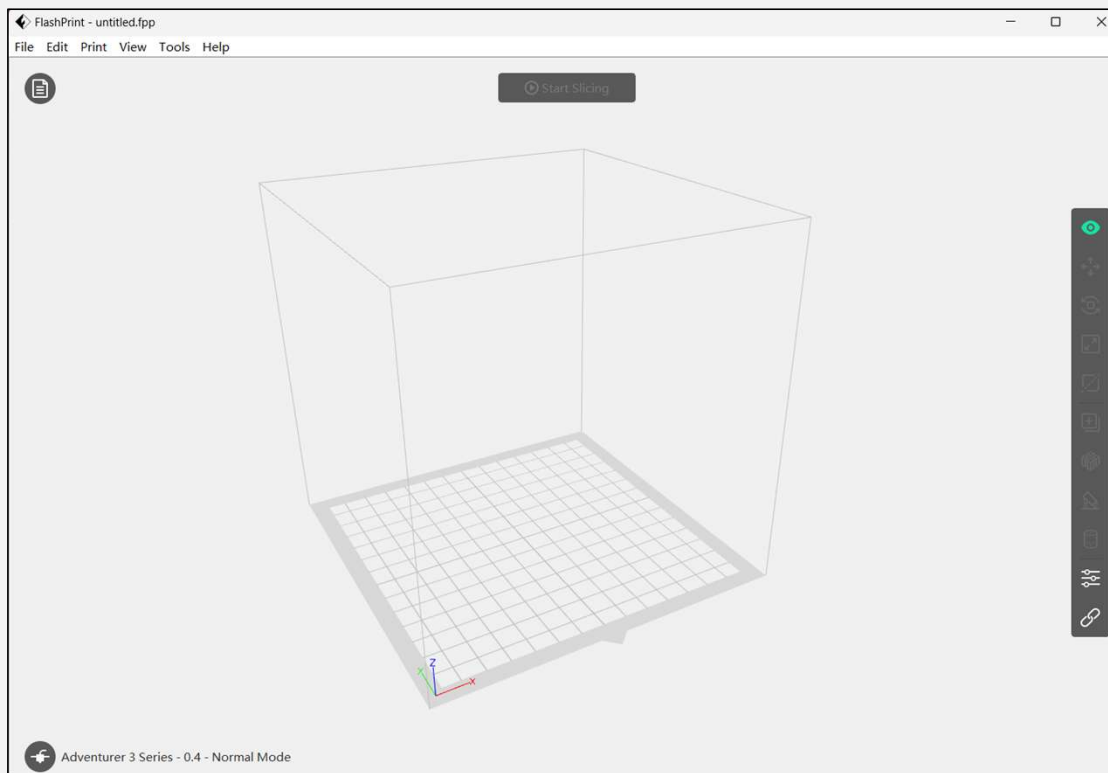

After FlashPrint 5 is downloaded, install it to your laptop.

Once done installation, open the FlashPrint 5 App.

3D Printer – FlashPrint 5 App

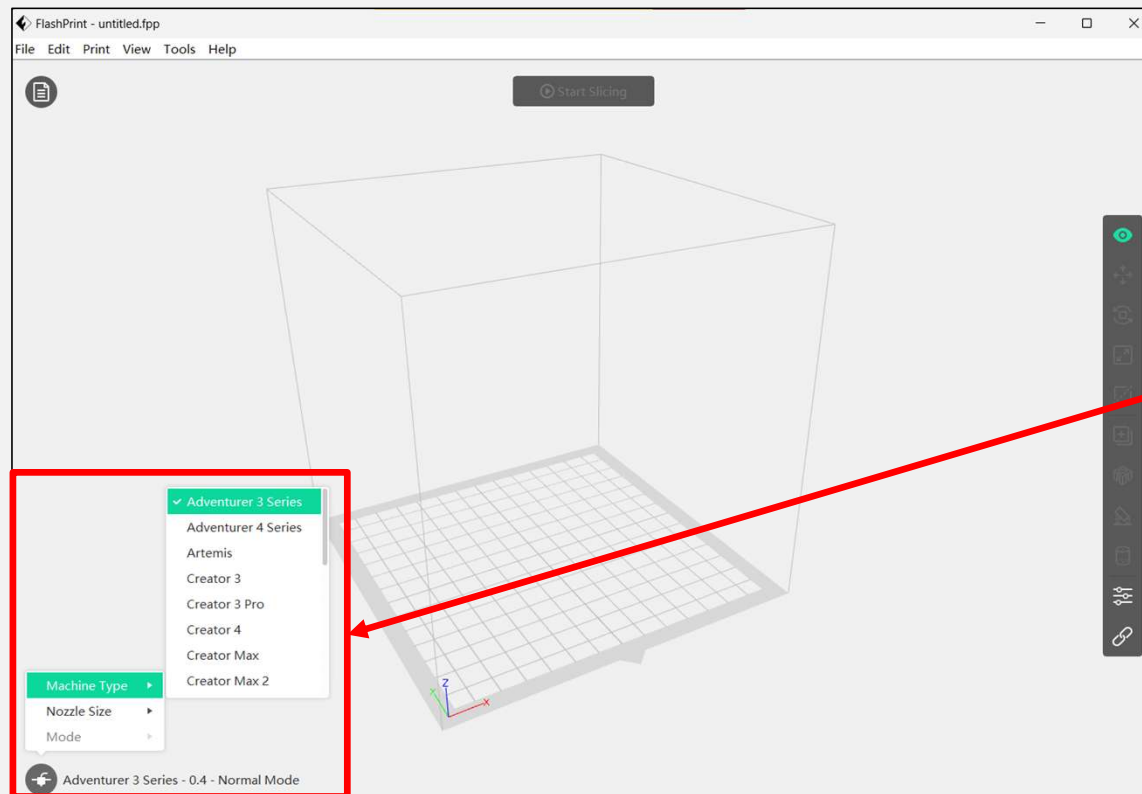

At the bottom left, we need to select the correct 3D printer we are using, which is Adventurer 3 Series.

3D Printer – FlashPrint 5 App

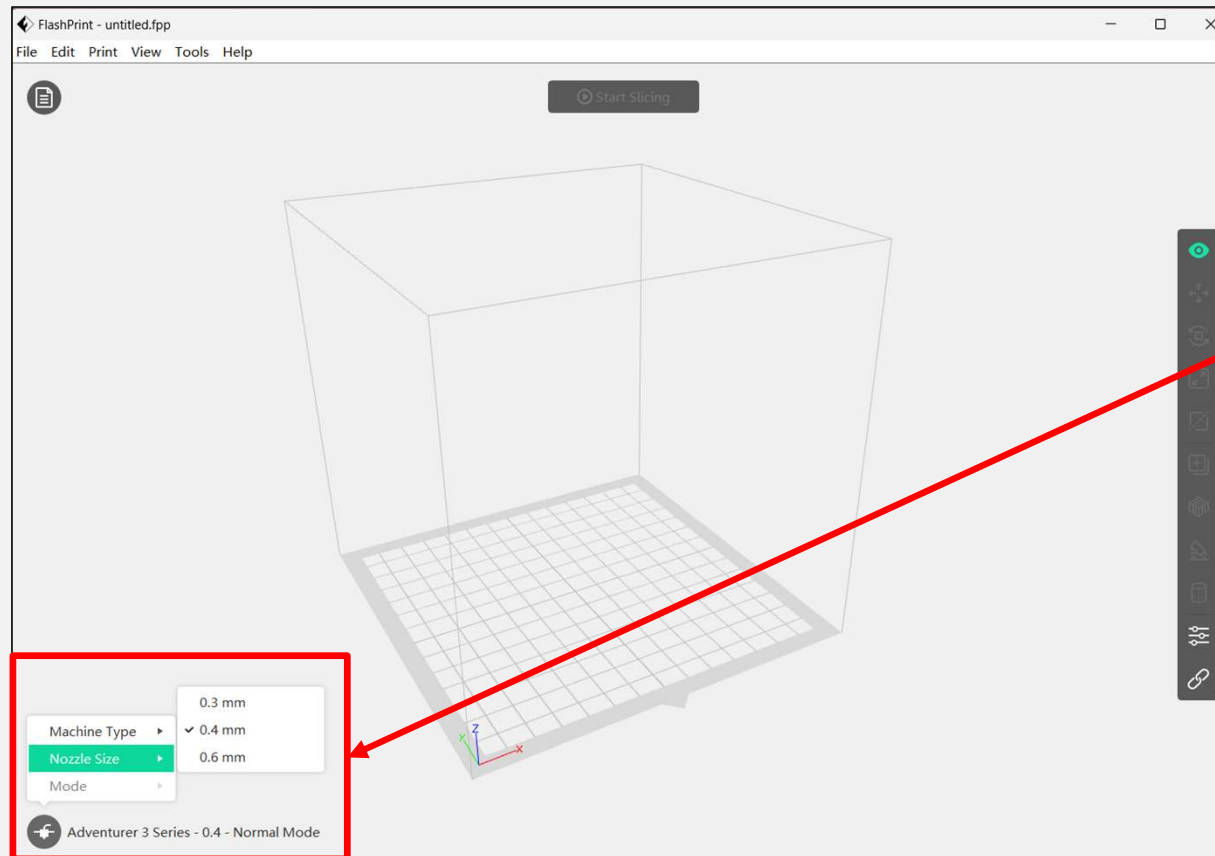

Nozzle size we set to 0.4mm.

3D Printer – FlashPrint 5 App

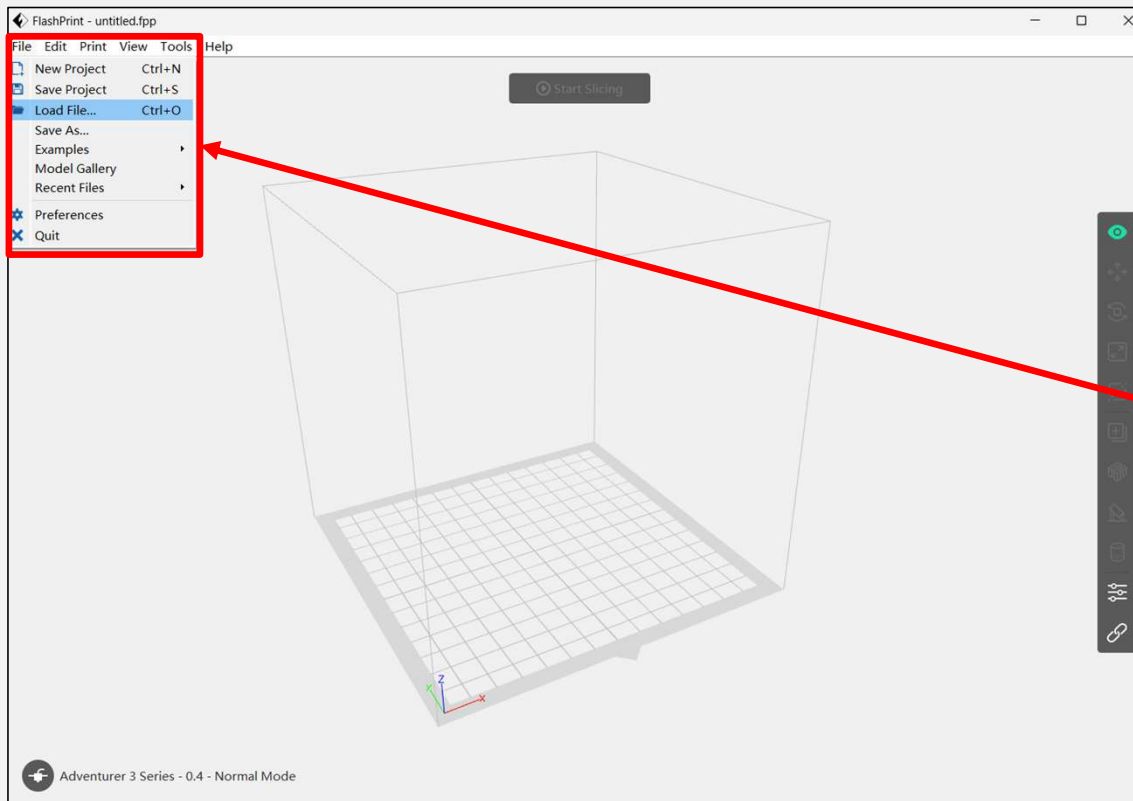

Then we can load our file exported from TinkerCAD.

Load your 3D file (with .stl format) to FlashPrint 5.

3D Printer – FlashPrint 5 App

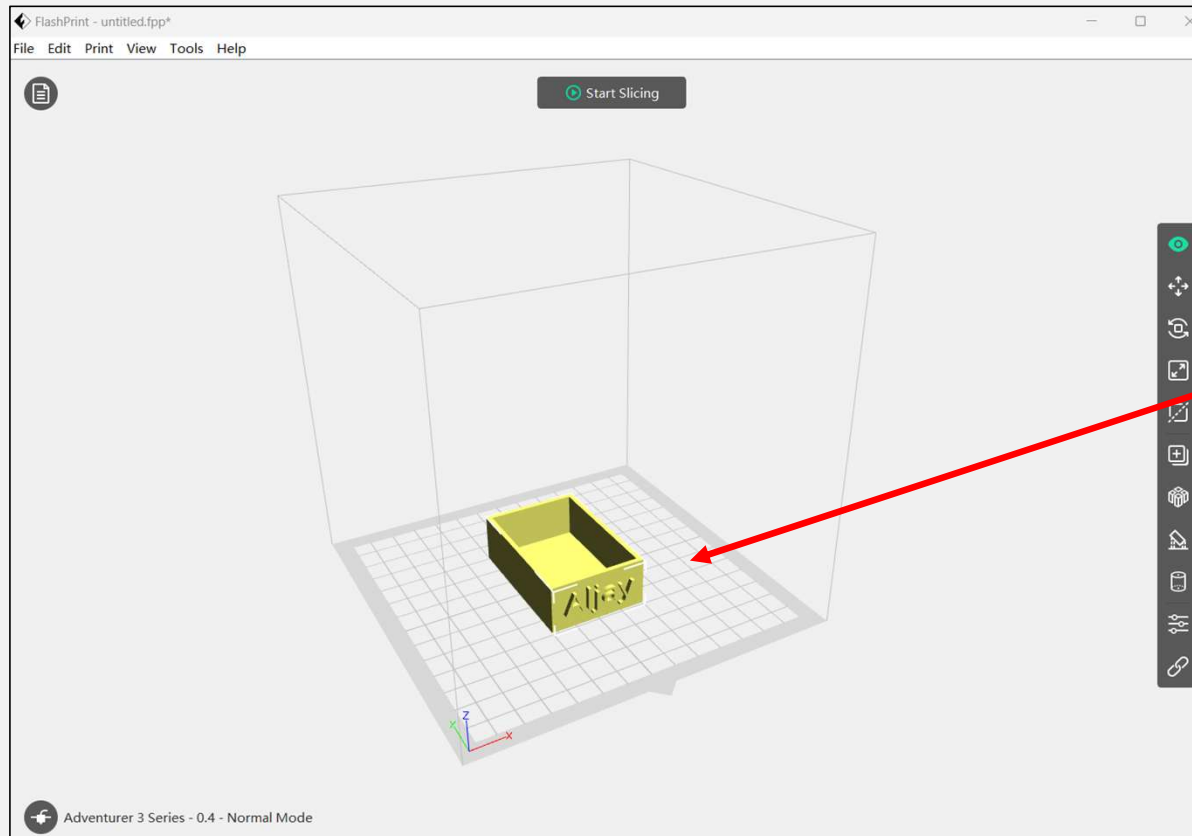

You will see your container shown in the virtual 3D printing area.

3D Printer – FlashPrint 5 App

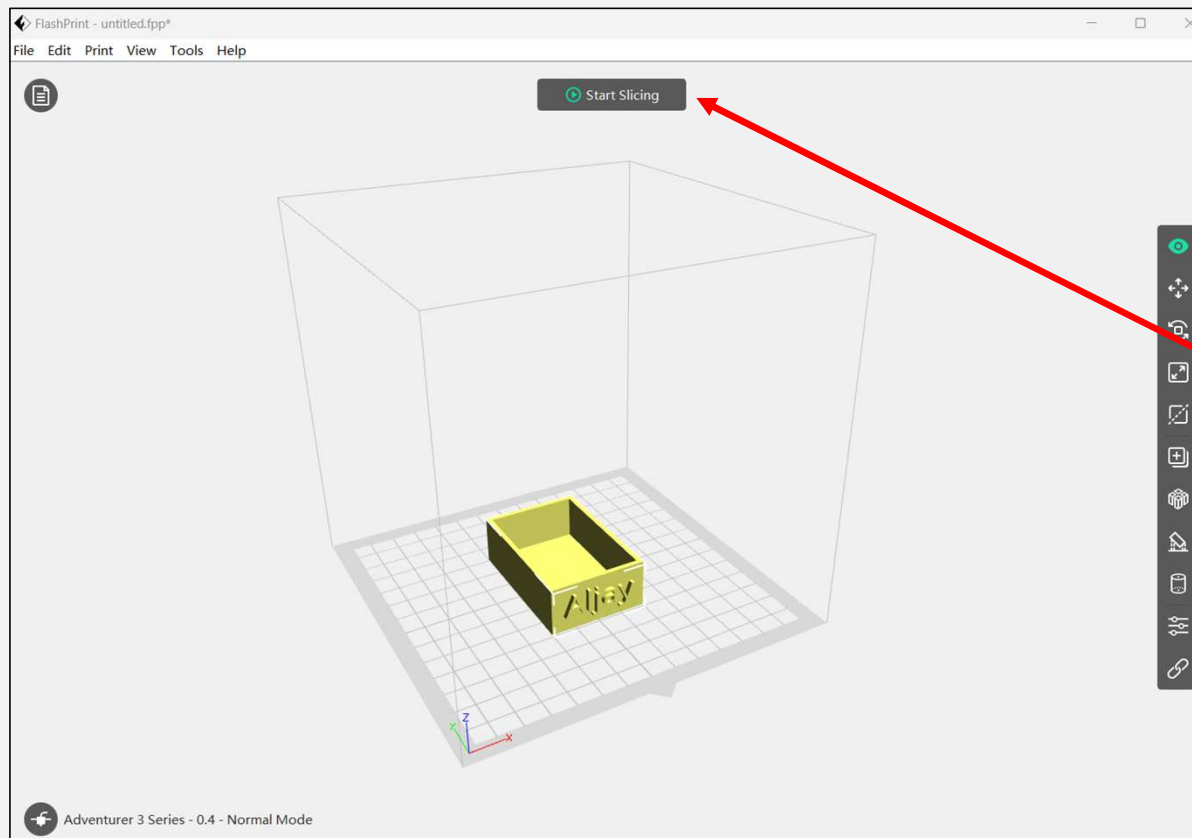

Click Start slicing.

This is to slice the 3D model to make it into different layer (z) of (x, y), to convert it to multiple layers.

3D Printer – FlashPrint 5 App

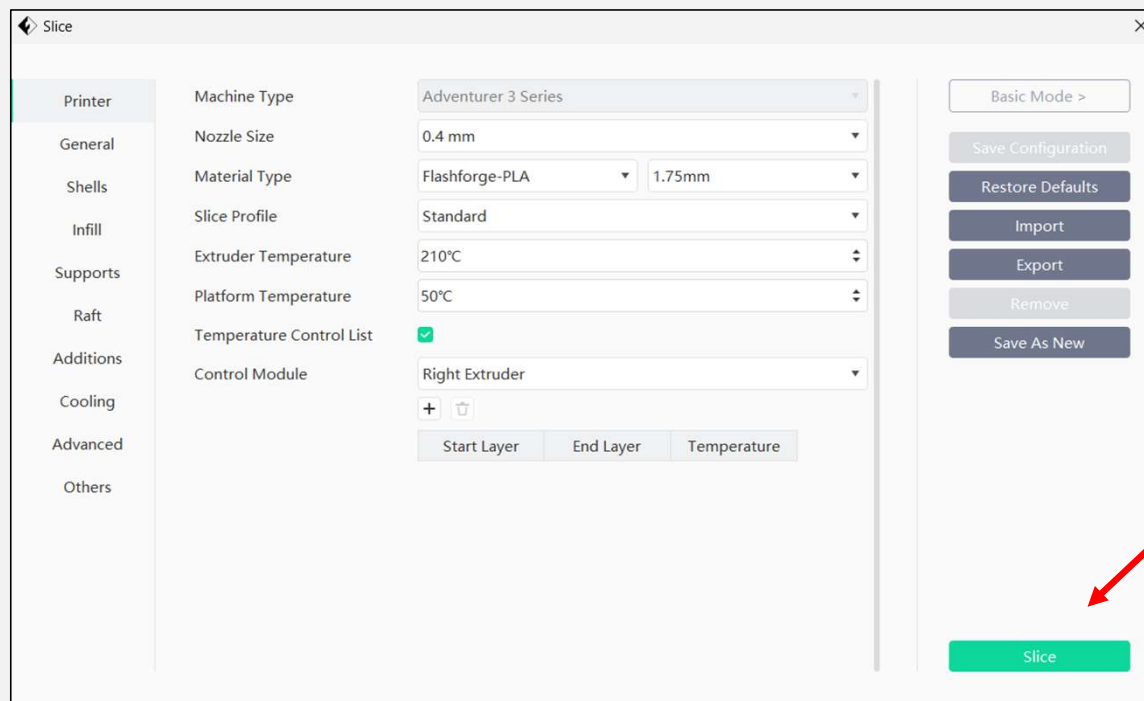

In this slicing setting we don't change anything for now yet. The detailed settings feature will be covered in advanced level.

So here we just need to click "Slice".

3D Printer – FlashPrint 5 App

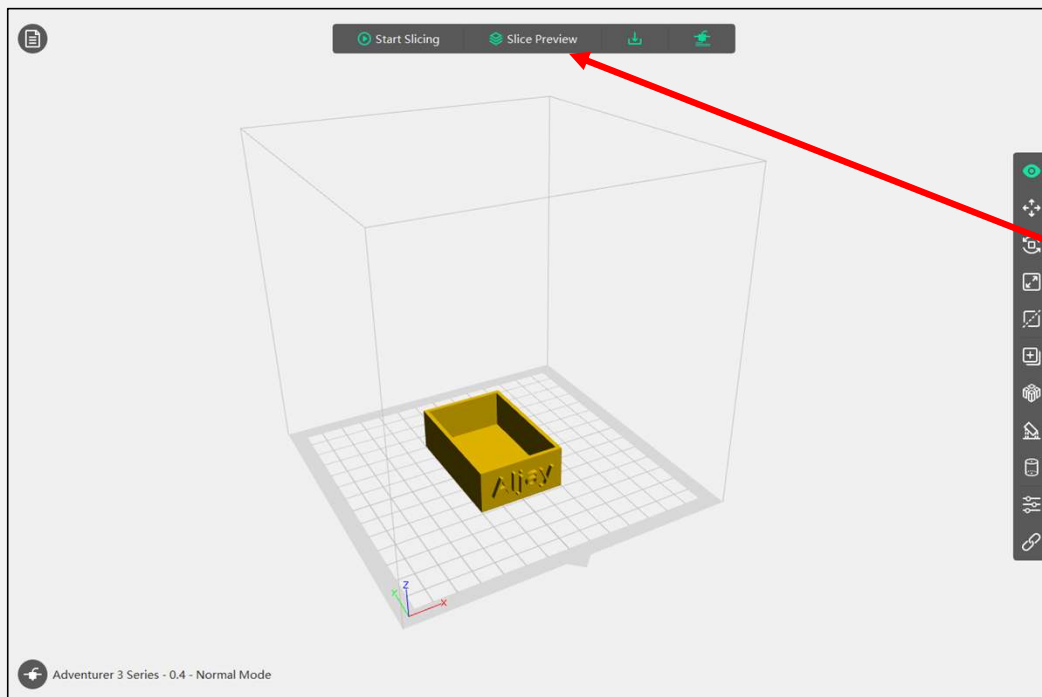

Once done slicing, you can check the slice preview, it will give you some information about your 3D model for 3D printing.

3D Printer – FlashPrint 5 App

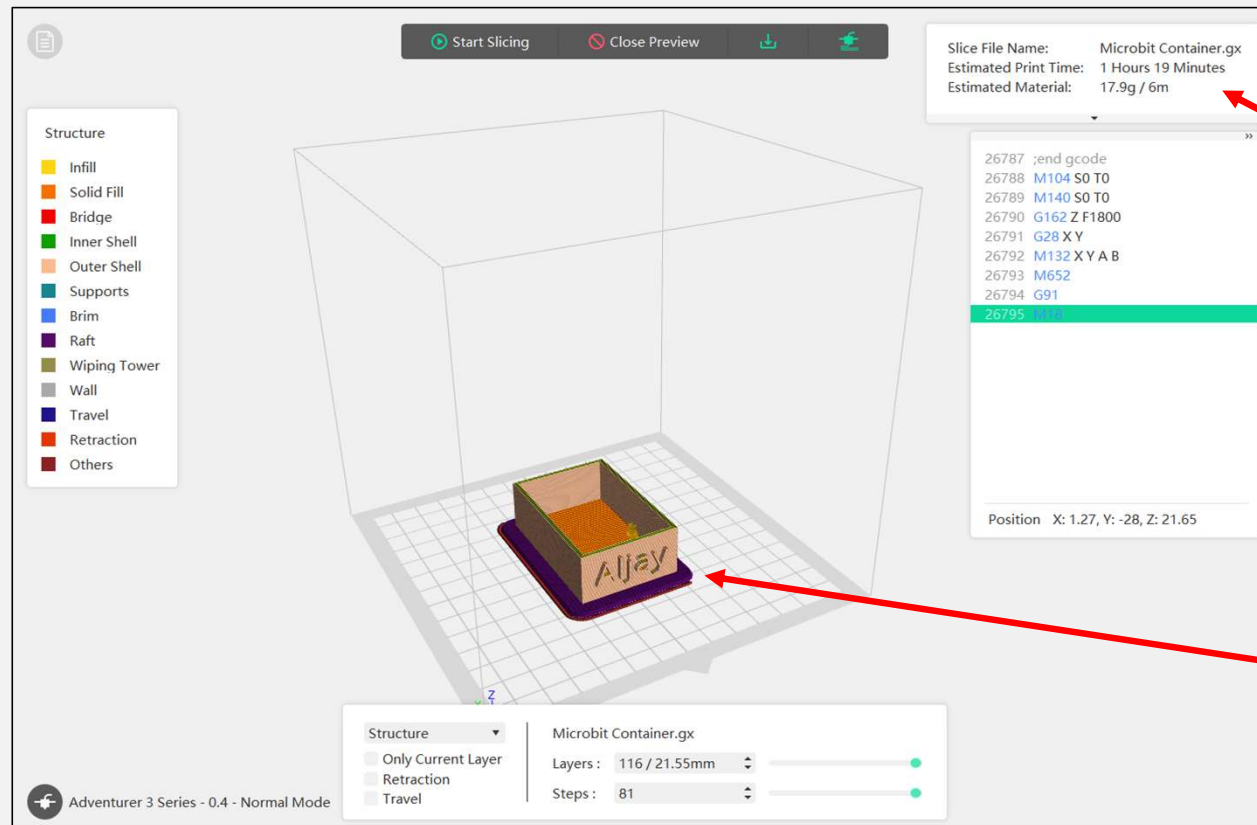

It will show the estimated print time and estimated material usage on the top right corner.

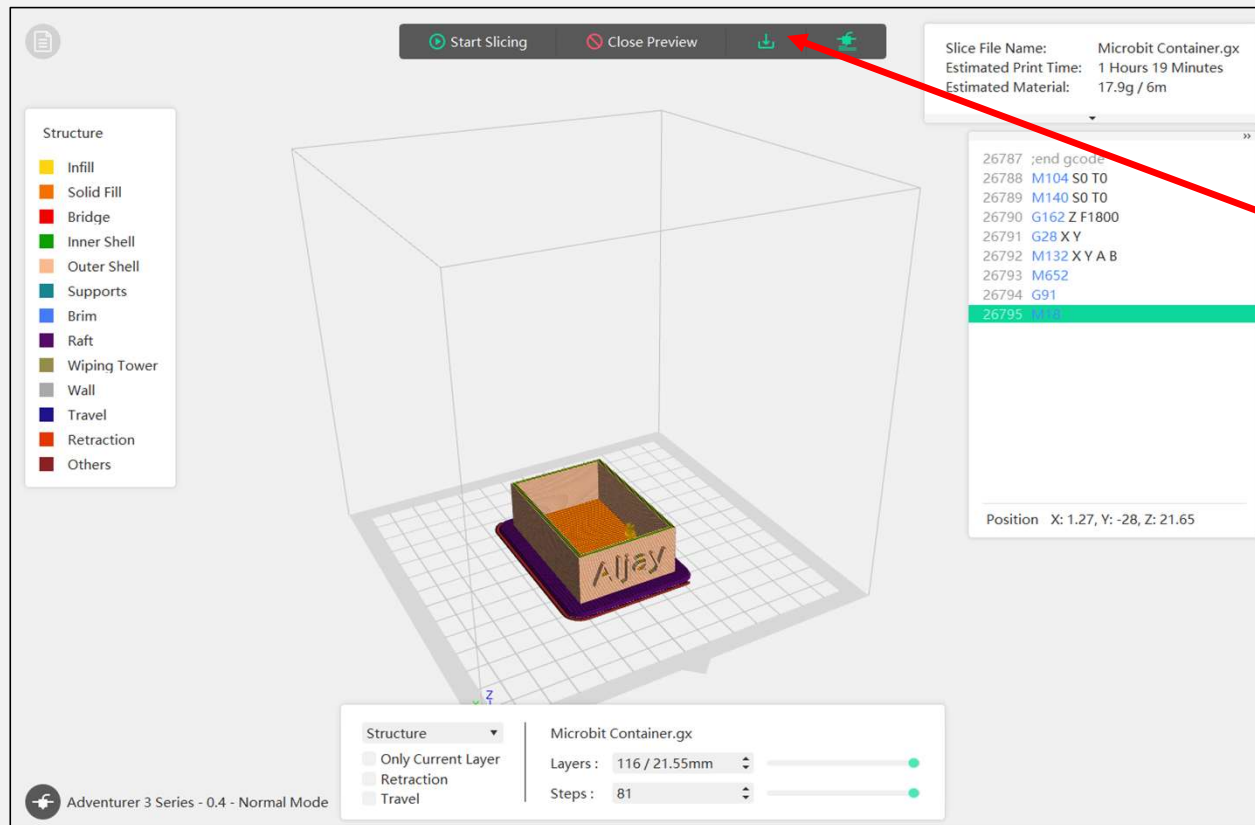

You can see now it will automatically add a bottom plate for the container, this is to make a base for it and easy to detach later when done.

3D Printer – FlashPrint 5 App



Now we can save it in gx code by clicking this "Save to Local".

3D Printer – FlashPrint 5 App

Today				
 Microbit Container.gx	21/3/2023 6:18 PM	GX File	666 KB	
 Microbit Container	21/3/2023 5:53 PM	STL File	57 KB	

Then you can save this into your pendrive for 3D printing.

The stl file would not be read in the 3D printer, so you don't need to download to your pendrive.

30 Points

CHALLENGE

for : Lesson 8

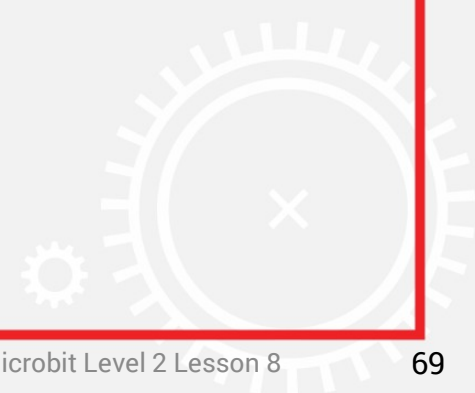

L8 - Challenge 1

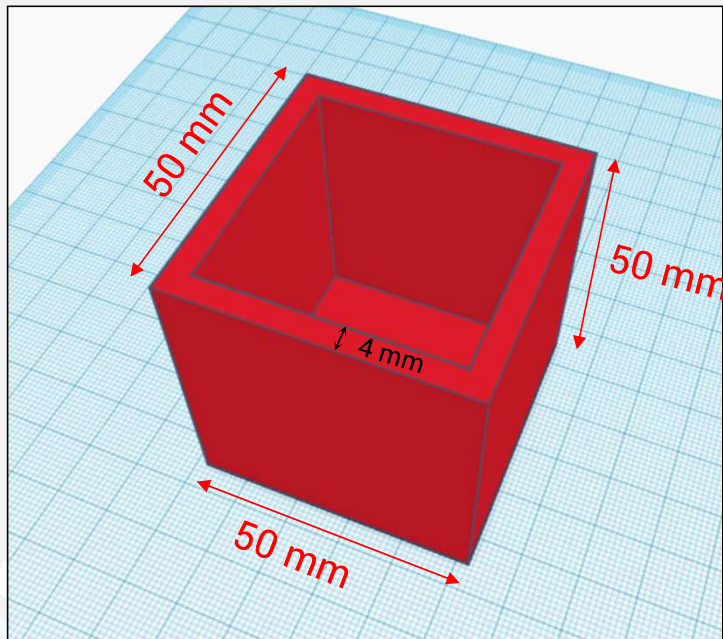

Design an opened cube container with 50mm each side (width, height, and length) with 4mm thickness each side.

30 Points

L8 - Challenge 2

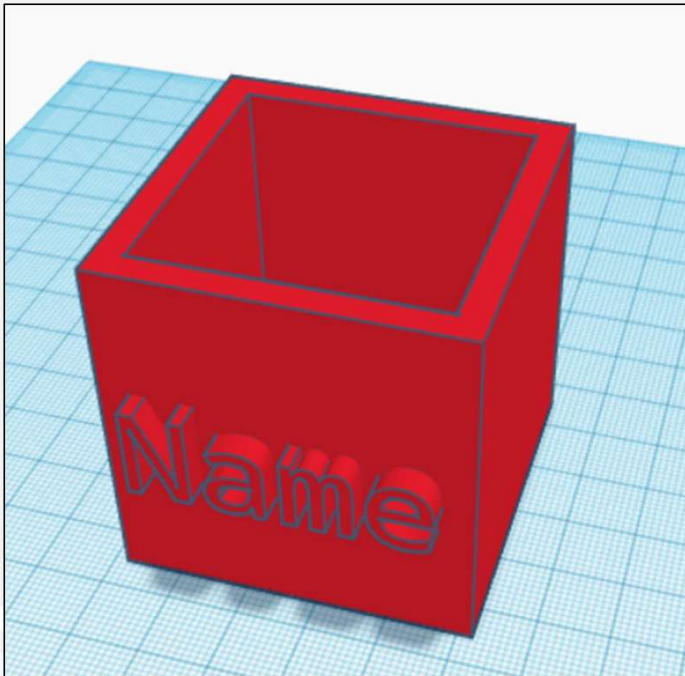

Put your name on it and make it with the thickness of 4mm.

Align the name to center on the front of your cube container.

30 Points

L8 - Challenge 3

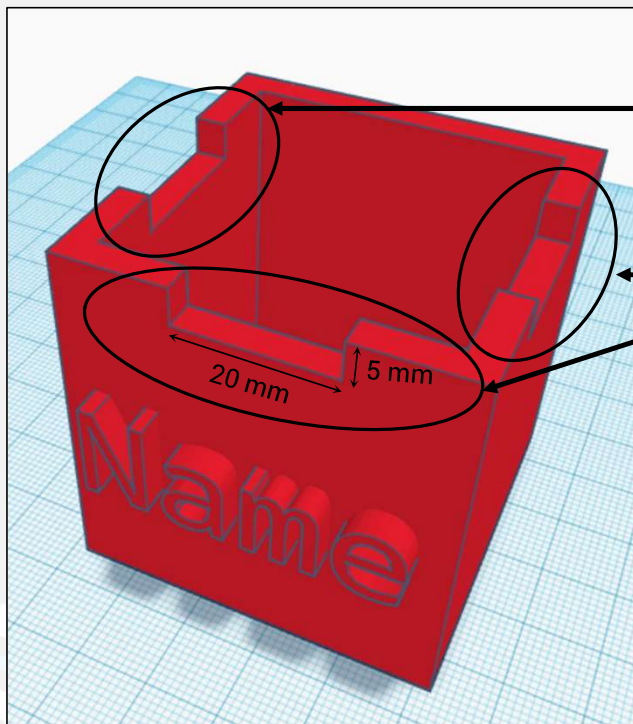

Can you make 1 notch at the top of each side except the back (right, left and front) with the size of 20mm width and 5mm height?

30 Points

Final Project - 3D Printing

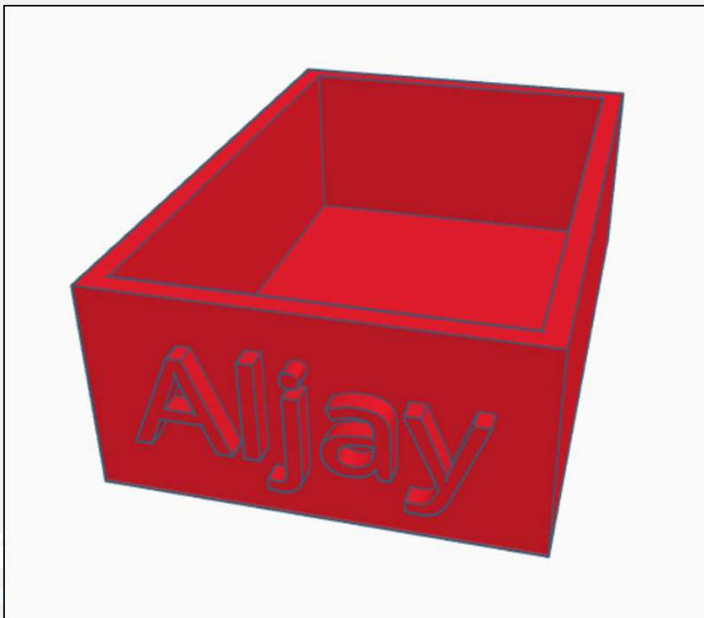

In your final project, your 3D model is limited to the dimension of

90mm (W) x 90mm (L) x 90mm (H)

And material usage is limited to

150 grams

****Do check your model after slicing and see if you have exceeded the limits. If yes, please modify your design and maybe trim down some unimportant parts.***